

2.200 GROUND AND FLIGHT CHECK FOR 100-HOUR/ANNUAL INSPECTION

Complete following checklists in conjunction with a 100-hour or annual inspection. Note and correct any discrepancies.

2.205 Ground Check (Aircraft not running)

1. **Throttle Control:** Check for freedom of rotation with collective full down and full up. \_\_\_\_\_
2. **Throttle Overtravel Spring:** Check by twisting throttle past idle position to override stop. Release throttle and ensure it returns to normal idle position. \_\_\_\_\_
3. **Mixture Control:** Check for smoothness of operation with no binding. Check press-to-unlock button for proper function. Verify 0.03 to 0.10 inch spring-back at full rich position. \_\_\_\_\_
4. **Carburetor Heat Control (O-540 only):** Check for smoothness of operation with no binding. Verify 0.03 to 0.10 inch spring-back at full off position. \_\_\_\_\_
5. **Cyclic Control:** With trim motors (if installed) in neutral position, verify freedom thru full travel with friction off. Verify friction knob rotates 1/8-to-1 full turn before adding friction. For hydraulic controls: Verify approximately one-half inch total longitudinal and one inch total lateral freeplay before encountering resistance. Verify normal hydraulic resistance with no binding or abnormal feel throughout control travel. \_\_\_\_\_
6. **Collective Control:** Verify freedom through full travel with friction off and on. For non-hydraulic aircraft, verify friction knob moves 0.3-0.6 inch before adding friction. For hydraulic controls: Verify approximately one-half inch total freeplay before encountering resistance. With carb heat assist (if installed) locked and friction lever fully off, verify C334 friction (between rear seats) within freeplay range is 4-5 pounds average measured at grip. With friction lever fully on, verify 18-22 pounds measured at grip. Verify normal hydraulic resistance with no binding or abnormal feel throughout control travel. \_\_\_\_\_
7. **Carb Heat Assist (if installed):** With collective down and full carb heat, raise collective full up and verify carb heat off. Lower collective full down and verify carb heat full on. With collective friction off, push carb heat off and verify collective stays down. \_\_\_\_\_
8. **Tail Rotor Pedals:** Check for smooth operation with no binding. \_\_\_\_\_
9. **Removable Controls:** Verify security of attach fasteners. \_\_\_\_\_

2.205 Ground Check (cont'd)**10. Lighting and Instruments: (Master Switch on)**

- a. CARBON MONOXIDE warning light flashes twice (if installed). \_\_\_\_\_
- b. Carb Air Temp approximately same as Outside Air Temp. \_\_\_\_\_
- c. ALT warning light on. \_\_\_\_\_
- d. OIL pressure warning light on. \_\_\_\_\_
- e. AUX FUEL PUMP warning light on (IO-540 only). \_\_\_\_\_
- f. Fuel quantity gages - indication of fuel level. \_\_\_\_\_
- g. Navigation and panel lights - check function. \_\_\_\_\_
- h. Strobe light - check function. \_\_\_\_\_
- i. Landing lights - check function (clutch switch must be engaged to check landing lights). \_\_\_\_\_
- j. Map light - check function. \_\_\_\_\_
- k. Ammeter - shows discharge. \_\_\_\_\_
- l. Oil temperature gage - slight needle deflection with engine cold. \_\_\_\_\_
- m. Cylinder head temp gage - slight needle deflection with engine cold. \_\_\_\_\_
- n. MR TEMP light - on when sender shorted or test switch depressed. \_\_\_\_\_
- o. MR CHIP light - on when sender shorted or test switch depressed. \_\_\_\_\_
- p. ENGINE FIRE light - on when sender shorted or test switch depressed. \_\_\_\_\_
- q. TR CHIP light - on when sender shorted or test switch depressed. \_\_\_\_\_
- r. LOW FUEL light - on (slight delay is normal) when low fuel sender in tank is depressed with clean, non-sparking rod or when test switch depressed. \_\_\_\_\_
- s. FUEL FILTER light - on when test switch depressed (IO-540 only). \_\_\_\_\_

11. Verify aircraft checklist laminated card is current revision (refer to Section 1.002). \_\_\_\_\_

2.210 Run Up

- 1. Perform POH Section 4 "Preflight" checklist. \_\_\_\_\_
- 2. Perform "Before Starting Engine" checklist. \_\_\_\_\_
- 3. IO-540 engine: Verify AUX FUEL PUMP light extinguishes during prime and illuminates after priming. Verify fuel drains from sniffle valve. \_\_\_\_\_

**NOTE**

Significant prime may be required before fuel drains from sniffle valve. Wait for valve to stop draining before starting engine. Engine will be hard starting/flooded while valve is draining.

- 4. Perform "Starting Engine and Run-Up" checklist. If less than 15 minutes has elapsed since Step 3, use minimum or no prime. \_\_\_\_\_
- 5. With alternator switch ON, verify ammeter shows positive charging indication and ALT light off. \_\_\_\_\_
- 6. Check clutch engagement time – maximum 80 seconds. \_\_\_\_\_
- 7. Both magnetos ground (off momentarily) at 60% RPM. \_\_\_\_\_
- 8. Verify ALT light illuminates within 10 seconds after alternator is switched OFF. Verify tachometer operates with alternator and battery switches off. Turn battery & alternator switches on. \_\_\_\_\_
- 9. No unusual bearing noise when varying RPM through operating range (mechanic to listen near V-belt drive). Refer to §§ 2.110 and 2.501 thru 2.503. \_\_\_\_\_
- 10. Set RPM at 75%, governor on. Increase to 85%, release throttle, and verify governor increases RPM to 101 to 102%. Increase RPM to 104%, release throttle, and verify governor decreases RPM to 101 to 102%. \_\_\_\_\_
- 11. Engine and rotor tach needles within 1% of each other at 102% RPM. \_\_\_\_\_
- 12. Verify alternator voltage as follows: \_\_\_\_\_
  - 13.4 to 13.9 vdc for 14-volt A942-3 alternator control unit
  - 27.75 to 29.25 vdc for 28-volt A942-4 alternator control unit
- 13. Heater operates properly. \_\_\_\_\_
- 14. Tachometer needles do not jump more than 2% when transmitting on 118.00, 125.00, and 136.975 MHz with governor on. \_\_\_\_\_
- 15. Raise collective control 0.5 inch at grip and slowly decrease RPM. Verify low-rotor-RPM warning horn and light activate at 97% to 96% RPM and remain on as RPM is decreased to idle. \_\_\_\_\_

2.210 Run Up (continued)

- 16. Idle RPM with engine warm, clutch engaged, throttle closed –
  - O-540 engine: 53% – 57% \_\_\_\_\_
  - IO-540 engine: 58% – 62% \_\_\_\_\_
- 17. Idle mixture with engine warm, clutch engaged, throttle closed. \_\_\_\_\_
  - O-540 engine: 2% to 4% RPM rise as mixture is pulled slowly to idle cut-off. Adjust idle mixture screw as required. If unable to obtain rise, set idle mixture screw 1 ½ turns out from fully in then adjust as required for smooth idle. \_\_\_\_\_
  - IO-540 engine: Adjust idle mixture per § 6.495, Step 23. \_\_\_\_\_
- 18. Check hydraulic system operation. Move cyclic-mounted hydraulics switch to OFF. Using small longitudinal cyclic inputs, there should be approximately one-half inch of freeplay before encountering stiffness and feedback. Turn hydraulics ON. Controls should be free with no feedback or uncommanded motion (“motoring”). Complete flight check with hydraulics on. \_\_\_\_\_
- 19. Air Conditioning: Verify system blows cold air on both low and high settings. Verify no EMI/RFI with other instruments and systems. After a flight with air conditioning on, verify water drains from drain tube in ship’s belly (may be little or no water in very dry conditions). \_\_\_\_\_

2.220 Flight Check

**1. Hover:**

- a. All gages green. \_\_\_\_\_
- b. Controllability in left and right pedal turns. \_\_\_\_\_
- c. Hydraulics zero cyclic stick forces. \_\_\_\_\_ |
- d. Vibration levels satisfactory. \_\_\_\_\_

**2. Level Flight:** Typical cruise altitude (if possible, deviate as required for weather and regulations), maximum continuous power, governor on.

- a. Vibration levels satisfactory. \_\_\_\_\_
- b. Hydraulics zero cyclic stick forces. \_\_\_\_\_ |
- c. Verify no feedback and collective is balanced. \_\_\_\_\_ |
- d. Tail rotor pedal position when yaw string is centered: 0.25 to 0.75 inch right for adjustable pedals, within 0.25 inch of neutral for non-adjustable pedals. \_\_\_\_\_
- e. Tail rotor elastic trim cord zeros pedal forces (cord applies left pedal force). \_\_\_\_\_
- f. Turn hydraulics OFF and verify no excessive feedback forces. \_\_\_\_\_ |

2.230 Shutdown

- 1. Verify rotor brake functions and ROTOR BRAKE light illuminates. \_\_\_\_\_
- 2. Complete shutdown per POH checklist. \_\_\_\_\_

Intentionally Blank

2.300 Airframe Preparation for 100-Hour/Annual Inspection

The helicopter must be thoroughly cleaned prior to inspection in accordance with U.S. 14 CFR Part 43, Appendix D, Paragraph (a). If needed, use a mild soap (pH between 7 & 9) and water solution per Chapter 23.

**CAUTION**

During pre-inspection cleaning, prior to removing any residue, note and identify both residue & source for follow-up examination. Residue may be fuel, oil, grease, paint, plastic, magnetic-metal, non-magnetic-metal, etc, including combinations; metal residue may indicate structural damage and requires careful attention. Residue may be visible on adjacent structure and not on the source part itself.

**CAUTION**

Do not spray magnetos, main rotor hub, tail rotor gearbox vent, hydraulic reservoir vent, swashplate area, or bearing seals with high-pressure water or solvent as water or solvent may enter and cause corrosion and breakdown of lubricants.

2.400 100-Hour/Annual Airframe Inspection

**CAUTION**

If pop-out floats are installed, ensure safety on pilot’s red inflation lever is in LOCKED position when working on helicopter.

**WARNING**

Pop-out float pressure cylinder contents are under extreme pressure. If pop-out floats are installed, install locking pin in pressure cylinder valve (see Figure 5-6) when working in forward left baggage compartment, during cylinder removal or installation, and when working on floats or inflation hoses. Remove locking pin when work is completed. Avoid excessive heat (> 200 degrees F) as thermal relief valve will activate.

Perform 100 hour or annual airframe inspections per § 2.410. RHC recommends keeping a copy of the most recently performed checklist with the aircraft’s maintenance records.

2.410 Inspection Procedures and Checklist

R44 Serial No.: _____	Technician name: _____
Registration No.: _____	Technician _____
Hourmeter Indication: _____	Certificate number: _____
Aircraft Total Time: _____	

Numbers in parentheses indicate access location per Figures 2-4 and 2-4A.

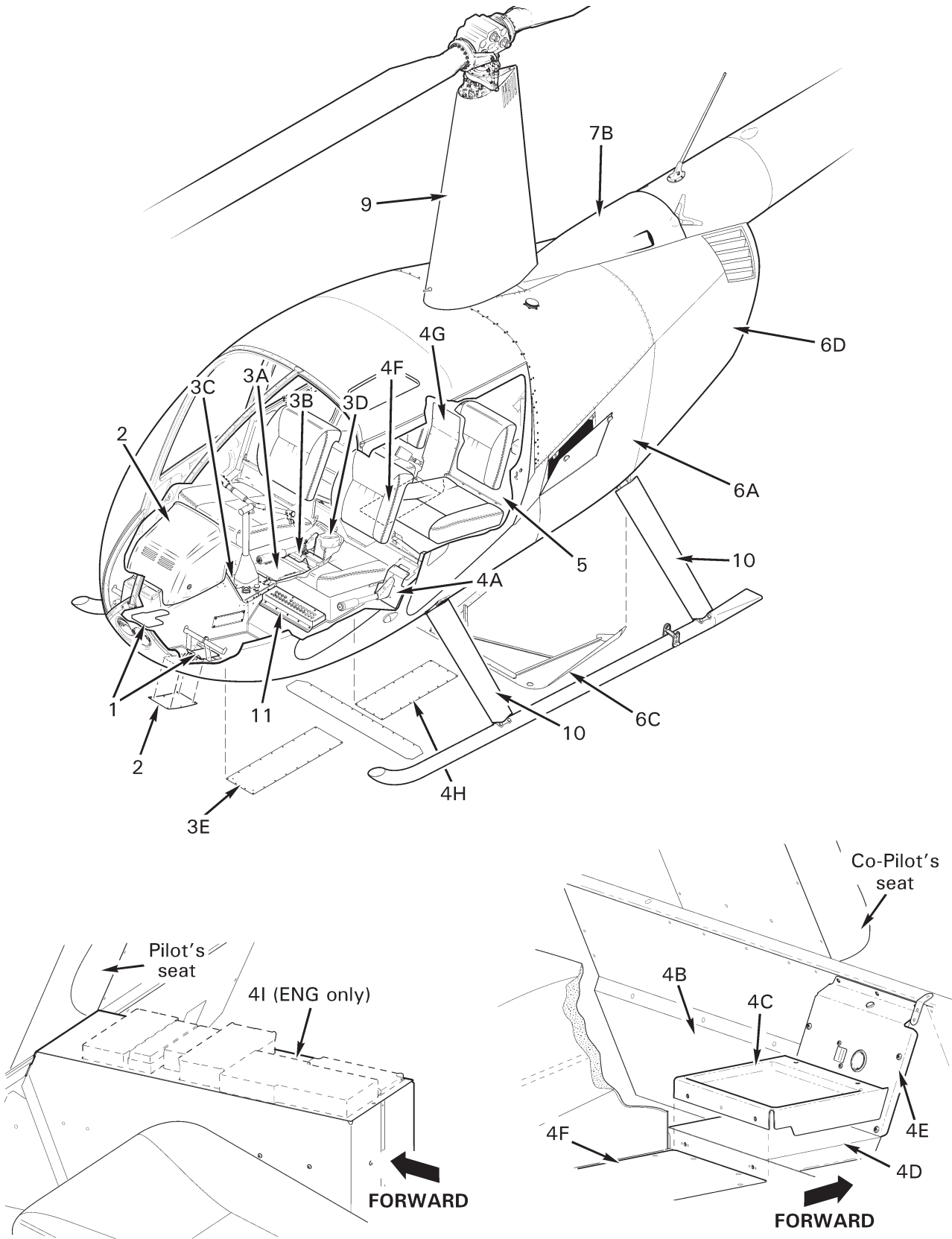
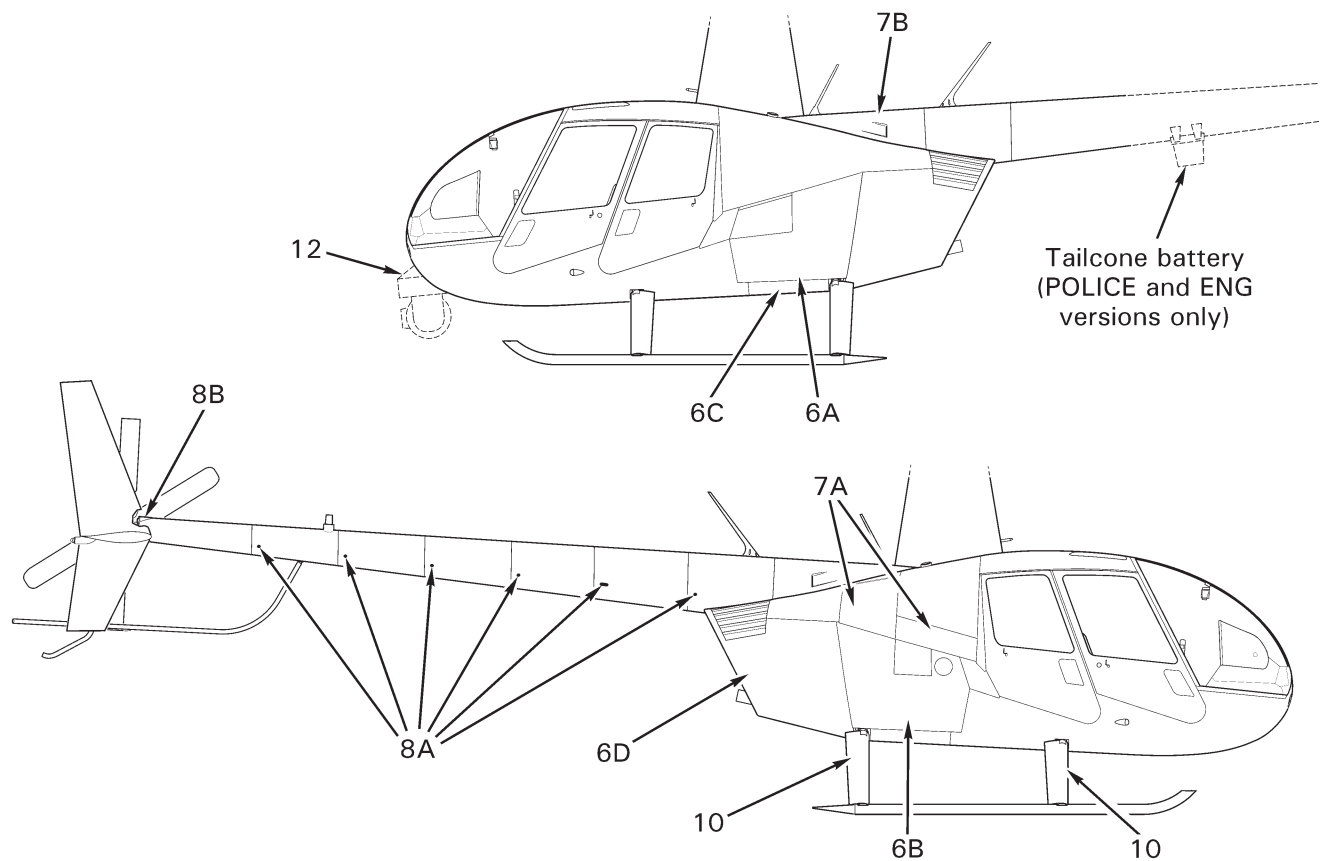

FIGURE 2-4 ACCESS AND INSPECTION PANELS



**FIGURE 2-4A ACCESS AND INSPECTION PANELS**

**2.410 Inspection Procedures and Checklist (continued)**

**1. Tail Rotor Pedal Bearing Blocks**

**NOTE**

Do not remove pedal bearing block cover plates (1) unless function check of pedals indicates possible problem with pedal bearing blocks.

To remove cover plates (1) peel back carpeting and remove screws holding plates. Use an inspection light and mirror to inspect bearing blocks. Inspect for condition and looseness or play. Maximum allowable play is 0.080 inch axially and 0.030 inch radially. Inspect all weld areas in pedal controls.

2.410 Inspection Procedures and Checklist (continued)

**2. Remove chin inspection cover, & remove or open upper console assembly per § 13-80:**

**CAUTION**

Instrument console removal (§ 13-80) is not required for scheduled inspections. Sufficient access for inspection is gained by removing the chin inspection cover, as well as removal of installed avionics, as required (refer to Chapter 38).

**Upper Console Assembly:** Inspect condition. Verify hinge security.

**Pitot-Static System:** Check pitot and static lines for cracking, chafing, pinching or kinking. Check all connections for security. \_\_\_\_\_

**Flight and Engine Gages:** Check all gauges for security. Inspect wiring and connections on all gages. \_\_\_\_\_

**Radio Tray(s):** Check condition and security. \_\_\_\_\_

**Tail Rotor Controls:** Check accessible portions of TR pedal assemblies for defects. Verify operating clearance. \_\_\_\_\_

**3. Remove Forward Tunnel Covers (3A & 3B), Cyclic Stop Cover (3C), Inboard Collective Cover (3D), and Forward Belly Panel (3E)** \_\_\_\_\_

**NOTE**

If radio antennas are installed on removed panels, disconnect antenna lead and any ground wire. Pull respective radio circuit breaker and tag circuit breaker with "Antenna Removed".

**Cyclic Box Assembly:** Inspect cyclic box assembly for defects. Check cyclic stop sheet metal assembly for cracks and other defects (deterioration, distortion, loose rivets, corrosion). \_\_\_\_\_

**Cyclic Stick Assembly:** Inspect cyclic stick assembly for defects. Inspect welds for cracks. \_\_\_\_\_

2.410 Inspection Procedures and Checklist (continued)

**3. Remove Forward Tunnel Covers (3A & 3B), Cyclic Stop Cover (3C), Inboard Collective Cover (3D) and Forward Belly Panel (3E) (continued)**

**Cyclic Friction:** Check for excessive play or looseness in links and rod ends connected to cyclic stick. Verify no excessive flaring at either end of C130-2 spacer. \_\_\_\_\_

**Cyclic Push-Pull Tube and Torque Tube:** Inspect C319 torque tube paying special attention to area around blocks and end of torque tube for cracks. Inspect C121-1 push-pull tube rod end palnut and jam nut for tightness. Check witness holes on push-pull tubes. Check rod ends and bearings for excessive play and looseness. Check accessible portions of cyclic push-pull tube and torque tube for defects, including scratches. Pay particular attention to top of torque tube immediately below C348-1 anchor assembly. Inspect all nuts and bolts in cyclic controls for rotation and looseness. Verify operating clearance. \_\_\_\_\_

**Tail Rotor Push-Pull Tube:** Inspect accessible portions of C121-9 tail rotor push-pull tube. Check rod ends for excessive play and looseness. Verify operating clearance. \_\_\_\_\_

**Collective Friction and Stop:** Inspect collective stop condition; no nicks, cuts or scratches are allowed. Check collective friction lever for security and operation. Move collective up and down and verify no bending or binding of stop. Verify collective boot’s lace cannot entangle stop. \_\_\_\_\_

**Throttle Overtravel Spring:** Inspect operation of overtravel spring while operating throttle. It should move freely without any binding or jerkiness. Check play in upper and lower rod ends. Check rod ends for binding. \_\_\_\_\_

**HeliSAS Autopilot (if installed):** Inspect condition of associated equipment. Inspect wiring condition. Verify neatness, operating clearance, and security. \_\_\_\_\_

**Wiring Harness:** Inspect condition. \_\_\_\_\_

**Pitot and Static Lines:** Inspect pitot and static lines for security and any evidence of cracking, chafing, pinching or kinking from sharp bends. Open drains and check for moisture; close drains. \_\_\_\_\_

**Elastic Trim Cords – Cyclic:** With cyclic forward-right, feel forward elastic trim cords for voids which may indicate broken strands. \_\_\_\_\_

**Heater Hose:** Check heater hose for collapsed areas and chafing. \_\_\_\_\_

**Fasteners and Torque Stripes:** Inspect condition and verify security of all fasteners. Renew deteriorated torque stripes per Figure 2-1. \_\_\_\_\_

2.410 Inspection Procedures and Checklist (continued)

**4. Remove Outboard Collective Cover (4A), Collective Torque Tube Cover (4B), Tray (4C), Mid Tunnel Covers (4D & 4E), Aft Tunnel Covers (4F & 4G), Aft Belly Cover Panel (4H), and Rear Console (4I, ENG ships only) (continued)**

<p><b>NOTE</b></p> <p>If radio antenna is installed on removed panel, disconnect antenna lead and corresponding ground wire. Pull respective radio circuit breaker and tag circuit breaker with "antenna removed".</p>
--

**Collective Stick:** Inspect condition of collective stick. Inspect all welds for cracks. Inspect C328-1 connecting rod assembly giving special attention to points of attachment. Inspect governor motor and governor motor arm for looseness or binding. Inspect collective-activated micro switch for cracks or loose wires. Verify operating clearance of collective and throttle governor, to include no evidence of rubbing on inside of removed cover. \_\_\_\_\_

**Collective Stick Torque Tube:** Verify no corrosion pitting. Apply a corrosion-preventative compound such as LPS 2, ACF-50, or Corrosion-X to any unpainted, phosphate-coated area while avoiding contaminating governor friction clutch (a foam-type applicator works well). Ensure interior of open-end "box" structures at inboard attach point and at A205 fork connection are also treated. \_\_\_\_\_

**Aft End of Cyclic Torque Tube and Yoke Assembly:** Inspect torque tube and yoke, paying special attention to area around blocks and end of torque tube for cracks. Check play in bellcrank bearings per § 2.122. Inspect swaged bearing for movement in yoke. \_\_\_\_\_

**Aft End of Cyclic Horizontal Push-Pull Tube (C121-1) and Lower Ends of Vertical Push-Pull Tubes:** Inspect push-pull tubes for cracks. Check rod end jam nuts and palnuts for tightness and rod ends for play. Check rod end bearings for looseness. Inspect fork assembly areas. Check bearings for looseness. Check between bearings and swage for evidence of fretting. \_\_\_\_\_

**Aft End of (C121-9) Tail Rotor Push-Pull Tube and Lower Bearing:** Check witness hole. Check lower bellcrank bearing for play. Inspect all welds on support assembly for lower bellcrank and inspect surrounding sheet metal area for cracks. \_\_\_\_\_

**Elastic Trim Cord – Tail Rotor:** Feel elastic trim cord for voids which may indicate broken strands. \_\_\_\_\_

**Collective Push-Pull Tube (C121-19):** Check for binding or nicks. Check witness holes. Check jam nuts and palnut for tightness and rod end for play. \_\_\_\_\_

2.410 Inspection Procedures and Checklist (continued)**4. Remove Outboard Collective Cover (4A), Collective Torque Tube Cover (4B), Tray (4C), Mid Tunnel Covers (4D & 4E), Aft Tunnel Covers (4F & 4G), Aft Belly Cover Panel (4H), and Rear Console (4I, ENG ships only) (continued)**

**Elastic Trim Cord – Collective:** Feel elastic trim cord for voids which may indicate broken strands. \_\_\_\_\_

**Collective Friction Assembly:** Check jam nuts and palnuts for tightness and rod ends for play. Inspect all welds on bellcrank support assembly and inspect surrounding sheet metal for cracks and corrosion. \_\_\_\_\_

**Throttle Control Linkage:** Remove throttle control arm cover if cover is not transparent (under aft left seat [O-540], or inside tunnel [IO-540], at firewall). Inspect condition. Verify throttle control clearance to installed equipment and adjacent structure. Verify proper installation and security. Install cover. \_\_\_\_\_

**Fuel Valve and Fuel Line:** Inspect fuel line for damage and valve fittings for leakage (leakage is indicated by a blue or green residue, depending on fuel used, or odor of fuel). Verify no chafing of fuel lines. \_\_\_\_\_

**Fuel Valve-to-Knob Torque Tube:** Inspect condition. Verify attaching security. \_\_\_\_\_

Intentionally Blank

2.410 Inspection Procedures and Checklist (continued)

**5. Remove Aft Seat Back Assemblies (5)**

**Wiring:** Verify security, proper installation, and no deterioration. \_\_\_\_\_ |

**Pitot and Static Lines:** Check for security, chafing, and kinks. \_\_\_\_\_

**Air Conditioning Refrigerant Lines (if installed):** Verify security & no damage. \_\_\_\_\_

**Evaporator Drain Tubes and Valve (if installed):** Verify tubes are unobstructed. Place a container under sediment-tube protruding from bottom of tee-fitting into right-aft baggage compartment. Remove plug from sediment tube and allow any accumulated moisture and debris to drain. Reinstall plug. Simultaneously squeeze drain tube and sediment tube near tee-fitting and verify check-valve ball moves up momentarily. \_\_\_\_\_

**Strobe Power Supply & Alternator Control Unit:** Verify security. Inspect wiring. Inspect mounting panels for cracks. \_\_\_\_\_ |

**Blind Encoder & Governor Controller:** Verify security. Inspect wiring. Inspect mounting panels for cracks. \_\_\_\_\_ |

**Fasteners and Torque Stripes:** Inspect condition and verify security of all fasteners. Renew deteriorated torque stripes per Figure 2-1. \_\_\_\_\_

**6. Remove Engine Aft (6D), Belly (6C), and both side (6A & 6B) Cowlings**

**Vertical Firewall:** Inspect vertical firewall condition, especially around structural attachment points, verify no cracks, buckling or wrinkles. \_\_\_\_\_

**Fuse(s) and Fuse Holder(s) (if installed on vertical firewall):** Verify security and no corrosion. Verify correct fuses: -66 wire requires AGC-3 fuse, -1601/-1602 wires require AGC-5 fuse. If installed, -1226 wire requires AGC-3 fuse. \_\_\_\_\_

**Wiring:** Verify security, proper installation, and no deterioration. \_\_\_\_\_

**Electric Fuel Pump (IO-540 only):** Verify security, proper installation, unobstructed drain tube, and no leakage. \_\_\_\_\_

**Fuel Line & Hose(s):** Inspect condition. Verify security, proper installation, no leakage, & (IO-540 only) good condition of spirap insulation on fuel line between firewall & gascolator. If deteriorated, replace MS3367-5-9 ty-raps securing fuel hoses to clamps (reference R44 SB-67). \_\_\_\_\_

**Lower Steel Tube Frames:** Thoroughly inspect lower steel tube structure for corrosion and inspect all welds for cracks. Ensure frames are not chafed by wires, hoses, clamps, etc. \_\_\_\_\_

**Engine Cooling Panels:** Inspect cooling panels for cracks and missing fasteners. \_\_\_\_\_

**Oil Cooler(s):** Inspect oil cooler(s) and fittings for damage, leaks, cleanliness, and security. Check oil cooler mounting area(s) for cracks. \_\_\_\_\_

2.410 Inspection Procedures and Checklist (continued)

**6. Remove Engine Aft (6D), Belly (6C), and both side (6A & 6B) Cowlings (continued)**

**Oil Lines:** Inspect entire length of all oil lines and verify no cracks, abrasion, or broken clamps. Verify clearance; wires, ty-raps, and structure must not contact lines. \_\_\_\_\_

**Gascolator:** With fuel valve off, remove and clean gascolator bowl and filter screen. Verify no deterioration of gasket. If gascolator bowl is secured by threaded collar and ring, lightly lube threads and ring with A257-6 grease. Reassemble and turn fuel valve on. Safety wire after ensuring no leaks occur. Verify drain valve is secure and torque-stripped. \_\_\_\_\_

**Mixture Control:** Verify mixture control moves mixture control arm stop to stop. Inspect condition and verify security of mixture control cable clamps on bracket; push and pull cable housing to ensure it does not slip in clamps. Inspect condition and verify security of mixture control cable inner wire attachment to mixture control arm. Ensure freedom of rotation between mixture control arm and inner wire retention fitting (bolt) when arm moves. Verify mixture control safety spring is properly installed (so spring force holds mixture control arm at full-rich position if inner wire breaks). \_\_\_\_\_

**Throttle Correlation Rigging:** Check per § 10.150 and adjust as required. \_\_\_\_\_

**Full-Throttle Switch Rigging:** Check per § 37-70 and adjust as required. \_\_\_\_\_

**Throttle Control Linkage:** Inspect condition. Verify throttle control operating clearance to installed equipment and adjacent structure. Verify proper installation and security. \_\_\_\_\_

**Air Box & Alternate Air Door:** Ensure carburetor heat slider valve (if applicable) moves fully from stop to stop. Replace air filter (lubricating IO-540 air filter rubber with A257-8 rubber lubricant will facilitate sealing). Check air box for condition and security. Verify spring-loaded alternate air door opens without binding and closes completely. \_\_\_\_\_

**Engine Air Inlet Hose:** Verify no rips, holes, or collapsed areas. Remove hose from fuel-injected R44 II. Visually inspect inside of hose to verify no separation between outer and inner layers. Also, flex the hose in all directions and listen for a crinkling sound, which is an indication of separation. (An airworthy hose does not make a crinkling sound when flexed.) Replace any hose with any indication of separation. Install hose on fuel-injected R44 II. Verify correct installation & security. Ensure hose is not chafing frame. \_\_\_\_\_

**Carburetor Heat Scoop and Hose (O-540 engines only):** Inspect for condition and security. \_\_\_\_\_

**Heater Hose:** Inspect for condition and security. \_\_\_\_\_

2.410 Inspection Procedures and Checklist (continued)

**6. Remove Engine Aft (6D), Belly (6C), and both side (6A & 6B) Cowlings (continued)**

**Aft Engine Mount:** Inspect all welds for cracks. Verify no corrosion. Verify no contact between rod ends and C020 upper frame tabs per Figure 6-2. \_\_\_\_\_

**Lead-Acid Battery Installations (under left front seat, left-side engine compartment, or mounted to tailcone):** Refer to § 37-11. Inspect condition. Verify no cracks or corrosion on or near battery terminals. As required, perform capacity test per manufacturer’s instructions or replace battery. Verify battery cable security. Verify no corrosion in surrounding structure. \_\_\_\_\_

**Lithium-Ion Battery Installation (if equipped; under left front seat or left-side engine compartment):** Refer to § 37-12. Inspect condition. Verify no cracks or corrosion on or near battery terminals. Verify vent hose, comm connector wiring, and battery cable security. Perform scheduled maintenance as required. Verify no corrosion in surrounding structure. \_\_\_\_\_

**7. Open Cowling Doors (7A), Remove Tailcone Cowling (7B) & Mast Fairing (9)**

**Cowling Door:** Inspect hinges and latches for condition and security. \_\_\_\_\_

**Tailcone cowling:** Verify no cracks, air inlet obstructions, or loose rivets. \_\_\_\_\_

**Electrical and Antenna Wires:** Inspect condition. Verify security and no chafing, kinks or tight bends. \_\_\_\_\_

**Emergency Locator Transmitter (ELT; if installed):** In accordance with local regulation, test per ELT manufacturer instructions. If 406 Mhz ELT, confirm programming tag matches helicopter registration. If RHC installation, inspect condition of both primary hook & loop strap and secondary buckle strap or ty-rap; replace strap(s) if damaged or deteriorated. Verify ELT security and clearance to drive train. \_\_\_\_\_

**MRGB Input Yoke:** Inspect condition. Verify security and operating clearance. Verify security of magnets. \_\_\_\_\_

Intentionally Blank

2.410 Inspection Procedures and Checklist (cont'd)

**7. Open Cowling Doors (7A), Remove Tailcone Cowling (7B) & Mast Fairing (9)**  
(cont'd)

**Forward Flex Plate:** Inspect condition, particularly edges. Verify security. Verify bonded washers are securely bonded to both sides of each flex plate arm. Verify operating clearance.

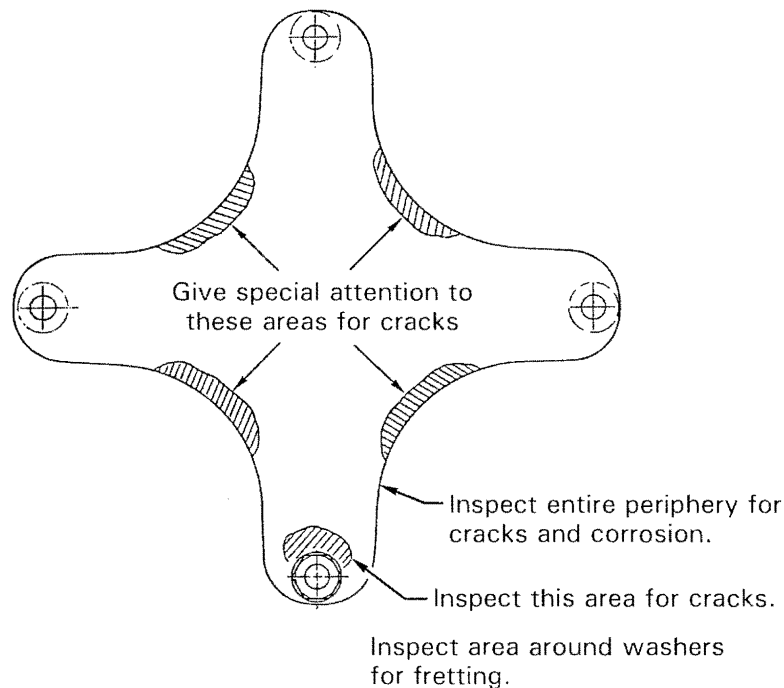

**FIGURE 2-5 FLEX PLATE INSPECTION**

**Clutch Shaft Forward Yoke:** Inspect condition. Verify no cracks, corrosion, or fretting. Verify security and operating clearance.

**Rotor Brake:** Inspect condition, including activating cable & pulleys and microswitch. Verify integrity of brake pads and 0.030 inch minimum pad thickness. Verify brake pad clearance to input yoke when brake is off. Verify security and operating clearance.

**Jackshaft:** Inspect entire welded assembly for cracks and corrosion. Inspect jackshaft supporting strut and tube weldments for security, cracks and corrosion.

**Main Rotor Push-Pull Tubes:** Inspect condition of viewable portions. Verify no cracks at ends. Inspect rod ends per Section 2.120. Verify no tears in sleeves (manual controls only). Verify security and operating clearances.

**Main Rotor Push-Pull Tube Rollers & Bushings: (manual controls only):** Inspect condition. Verify cleanliness, no wear into metal, and free movement of rollers.

2.410 Inspection Procedures and Checklist (cont'd)

**7. Open Cowling Doors (7A), Remove Tailcone Cowling (7B) & Mast Fairing (9)**  
(cont'd)

**Tail Rotor Push-Pull Tube and Upper Bellcrank:** Inspect C121-15 push-pull tube, especially at ends, for cracks. Check jam nut for tightness and rod end for looseness. Inspect bellcrank and mounting for cracks or other defects.

**Main Rotor Gearbox Cooling Hoses:** Inspect both ends for security. Inspect for rips, holes, and chafing.

**Main Rotor Gearbox:** Inspect main rotor gearbox, especially around gearbox mounts, cap mounting lugs, and mast tube for cracks. Verify no contamination and no deterioration of rubber mounts. Verify security of Hall Effect senders. Check Telatemp for overtemp indications.

**Main Rotor Gearbox Oil:** With ship on level ground, verify correct oil level and cleanliness using sight gage. If required by Section 1.101, drain and flush gearbox per Section 1.120.

**Main Rotor Gearbox Chip Detector:** If required by Section 1.101, clean chip detector per Section 1.115.

**Upper Steel Tube Frame:** Use an inspection light and mirror to inspect each weld, verify no cracks or corrosion.

**CAUTION**

Upper steel tube frame is fatigue-loaded and therefore susceptible to fatigue cracks. Inspect thoroughly.

**Horizontal Firewall:** Inspect upper and lower surfaces of horizontal firewall, especially where bolted to steel structure, for cracks, buckling, or wrinkles. Inspect firewall under fuel tank for leakage (fuel residue).

**Fuel Tanks:** Inspect condition of visible portion. Verify no leaks. Verify security.

**Auxiliary Fuel Tank Fuel Line:** Inspect condition. Verify clearance to structure. Verify no leakage. Verify security.

**Fuel Return Lines & Pressure Relief Valve (IO-540 only):** Inspect condition. Verify no leakage. Verify security.

**Fuel Gage Senders & Wiring:** Inspect condition. Verify no leaks.

**Fuel Tank Vents:** Check vent tube connections for security.

**Fuel Tank Sump Drains:** Verify both drain valves open easily, drain fuel freely, spring closed, and seal completely. Verify D663-1 shut-off clamp on aux tank drain tube seals completely, and inspect clamp and tube for damage and deterioration.

**Low Fuel Warning:** Turn MASTER switch on. With a clean wooden dowel, gently depress low-fuel sender float in main fuel tank and verify LOW FUEL warning light illuminates. Turn MASTER switch off.

2.410 Inspection Procedures and Checklist (continued)

**7. Open Cowling Doors (7A), Remove Tailcone Cowling (7B) & Mast Fairing (9) (cont'd)**

**Fuel Caps:** Inspect condition, to include gasket. Verify security when closed. Verify alignment marks on cap and tank align when cap is fully closed. Verify cap has aluminum bar shown in Figure 12-3A. \_\_\_\_\_ |

**Nuts and Bolts:** Inspect all nuts and bolts in this area for movement and looseness. \_\_\_\_\_

**Cabin Bulkhead & Forward Hydraulic Servo Mounts:** Inspect bulkhead and servo mounts (if installed) for corrosion, loose rivets, deformation and cracks. \_\_\_\_\_

**Clutch Assembly:** Inspect ends of drive shaft and seals on sheave for oil leakage. Inspect shaft for corrosion, especially at shaft-to-seal junctures. Remove any light surface corrosion at shaft-to-seal junctures, and apply B270-21 corrosion-inhibitor. \_\_\_\_\_ |

**Upper Sheave:** Inspect sheave grooves. Replace any sheave showing corrosion pitting or flaking of metalized or anodized coatings, wear through anodized coatings, roughness, or sharp ridges. \_\_\_\_\_

**Drive V-Belts (see Section 2.507):** Inspect V-belts. Verify no breakage, deterioration of rubber, cuts, fraying, oil, grease, or foreign objects. \_\_\_\_\_

**Actuator Fuses & Holders:** Inspect condition. Verify no corrosion. Verify correct fuses (14-volt systems require AGC-3 fuses while 28-volt systems require AGC-1 ½ fuses). Verify twist-to-lock function and security. \_\_\_\_\_

**Actuator Upper Bearing and Strut:** Inspect seals on both sides of bearing for damage. Inspect strut, including both rod ends, and check witness holes. Check for fretting between bearing inner races and clutch shaft. Bearing inner races should be torque striped to clutch shaft. If stripes are broken or misaligned, shaft is unairworthy. Check bearing Telatemp. Perform bearing inspection per § 2.503 if Telatemp indication has increased without corresponding increase in ambient temperature. \_\_\_\_\_

**Actuator Lower Bearing:** Inspect as much of bearing as can be seen. Inspect fiberglass scroll area at bearing attachment brackets for signs of cracking. Check bearing seals for evidence of deterioration. Inspect lower bearing brackets for looseness or wear. Inspect bearing per § 2.502 if discrepancies are found. \_\_\_\_\_

**Intermediate Flex Plate and Forward End of Tail Rotor Drive Shaft (see Figure 2-5):** Inspect flex plate for cracks and fretting. Inspect yoke-to-drive shaft weld for cracks (steel shafts). \_\_\_\_\_

**Tailcone Attachment:** Thoroughly inspect all welds in this area for cracks, corrosion, and security of attaching fasteners. Inspect tailcone mounting area for cracks. \_\_\_\_\_

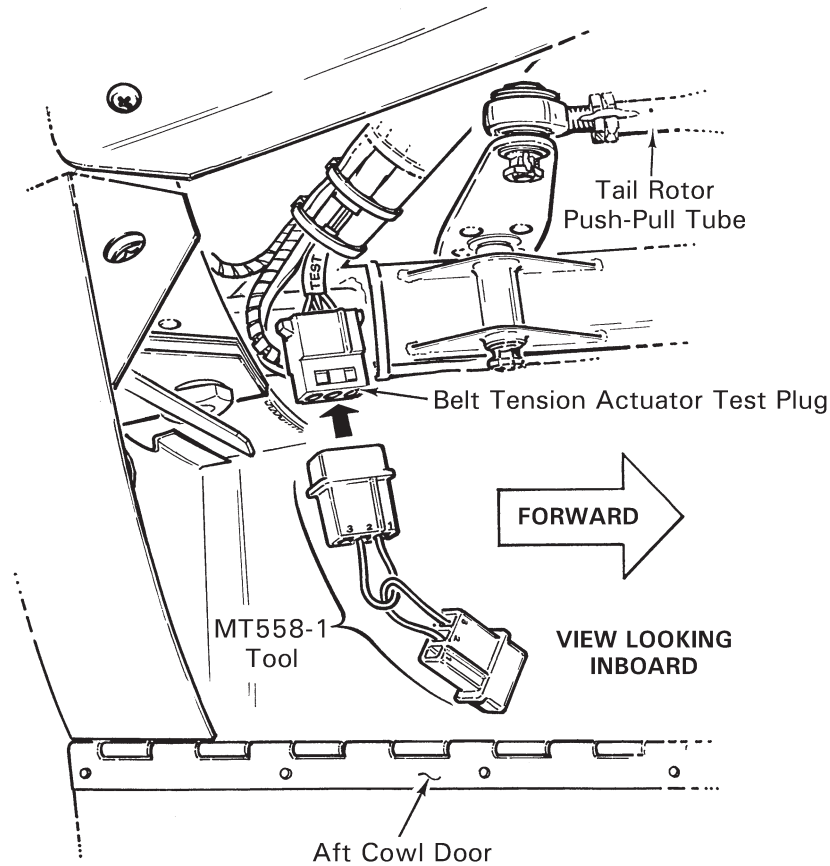

FIGURE 2-6 MT558-1 TOOL INSTALLATION

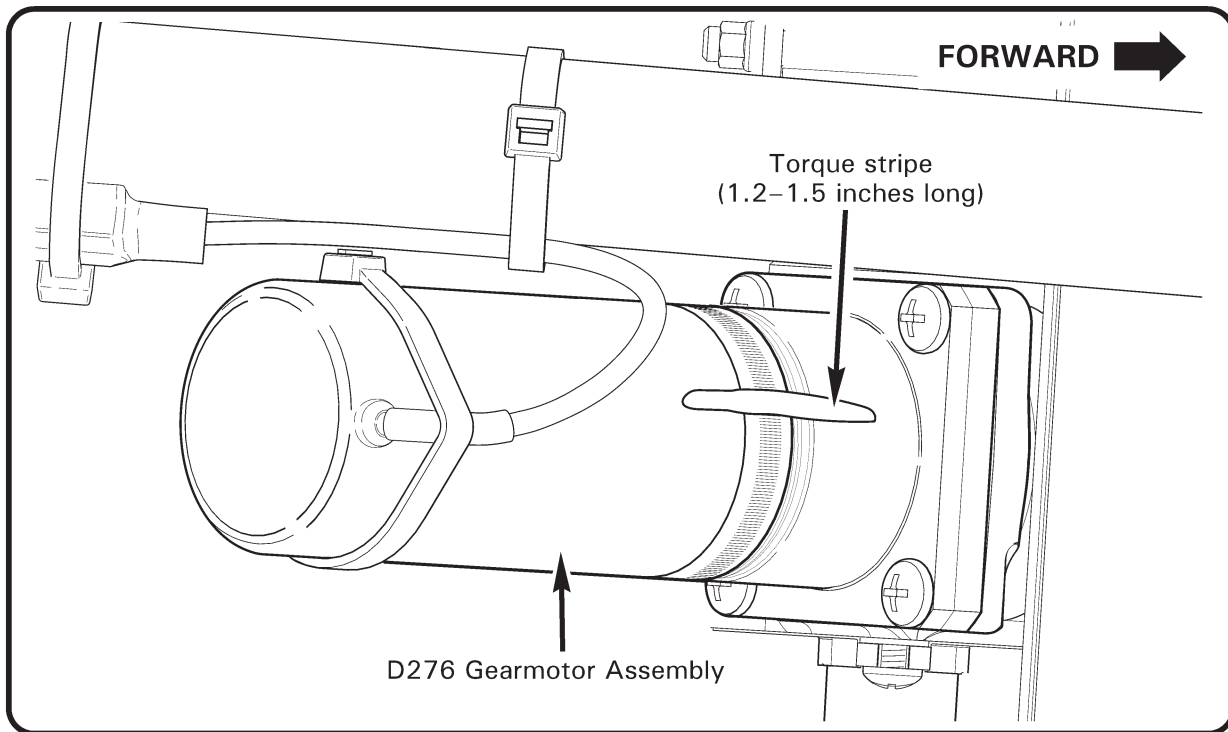

FIGURE 2-6A GEARMOTOR ASSEMBLY TORQUE STRIPE

2.410 Inspection Procedures and Checklist (continued)

**7. Open Cowling Doors (7A), Remove Tailcone Cowling (7B) & Mast Fairing (9) (cont'd)**

**Actuator (CO51):** Verify clearance to structure and drive train when fully disengaged. Turn master switch on and engage clutch switch. While actuator is engaging, depress extension limit switch lever (refer to Figure 7-15) and verify gearmotor stops; release lever and verify gearmotor resumes running. Verify integrity of activating cable for extension limit switch. Use an inspection mirror to observe column springs at end of belt-tensioning cycle; springs should snap outward simultaneously. Verify maximum engaged extension limit per Figure 7-15 is not exceeded. Verify clearance to structure and drive train when fully engaged. Verify down-limit stop screw jam nut is tight. \_\_\_\_\_

Check actuator for failed-closed spring switch as follows (actuator electrical harness must be equipped with "Test" plug per Figure 2-6):

- a. With BATTERY switch on and actuator fully engaged, connect one end of MT558-1 tool to actuator test plug and verify gearmotor remains off. \_\_\_\_\_

**CAUTION**

If gearmotor activates when installing MT558-1 tool then a spring switch has failed in closed position; immediately remove MT558-1 to prevent actuator damage.

- b. Disconnect MT558-1 tool, connect opposite end to actuator test plug, and verify gearmotor remains off. \_\_\_\_\_
- c. Disengage clutch and turn BATTERY switch off. \_\_\_\_\_
- d. MT558-1 pins 1 & 2 jumper tests wire 98 spring switch; pins 2 & 3 jumper tests wire 91 spring switch (see Figure 14-1D). Replace any malfunctioning switch per § 7.550 before further flight. \_\_\_\_\_

**Gearmotor Assembly Torque Stripe:** Refer to Figure 2-6A. Verify torque stripe is not broken or missing. Renew deteriorated torque stripe as required. \_\_\_\_\_

**Lower Drive Sheave:** Inspect lower sheave. Replace any sheave showing corrosion pitting or flaking of metalized coating, wear grooves, roughness, or sharp ridges. \_\_\_\_\_

**Sheave Alignment:** Verify sheave alignment per § 7.230. Adjust as required. \_\_\_\_\_

2.410 Inspection Procedures and Checklist (continued)

**7. Open Cowling Doors (7A), Remove Tailcone Cowling (7B) & Mast Fairing (9) (cont'd)**

**Hydraulic Reservoir:** Inspect condition. Verify security and no significant leakage. If required by § 1.101, replace filter per § 1.170. Drain and flush hydraulic system per § 1.180 if oil has turned dark or emits bad odor. Add fluid as required.

**CAUTION**

Cleanliness of hydraulic fluid is vital to proper system operation. Use only clean fluid from sealed containers and avoid contamination from dirty funnels, tubing, etc.

**Hydraulic Reservoir Cooling Hose:** Inspect condition. Verify hose is secure and is directed at center of reservoir cooling fins.

**Hydraulic Pump:** Inspect condition. Pump temperature indication should not exceed gearbox temperature indication. Verify security and no significant leakage.

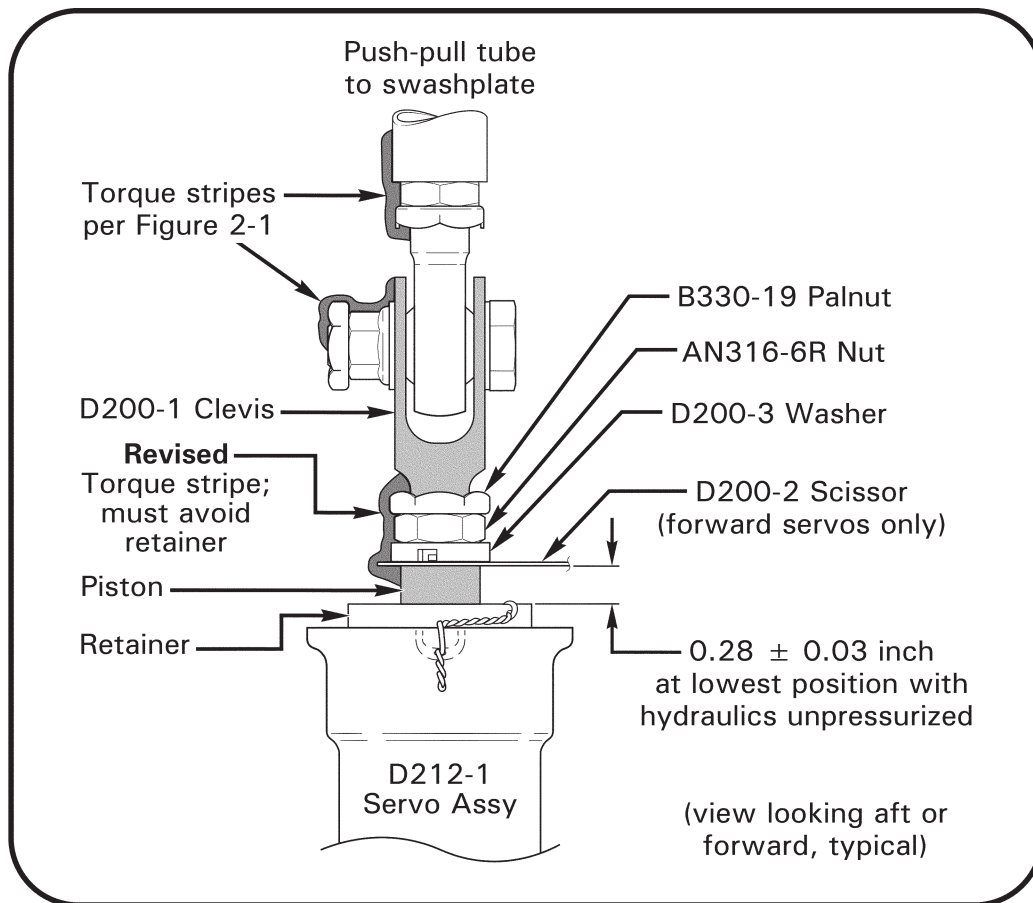

FIGURE 2-7 CLEVIS TORQUE STRIPE

2.410 Inspection Procedures and Checklist (continued)

**7. Open Cowling Doors (7A), Remove Tailcone Cowling (7B) & Mast Fairing (9) (cont'd)**

**Forward Hydraulic Servos:** Inspect condition; verify no obvious defects. Hydraulic fluid seepage is permissible ("seepage" is evidence of fluids without flow, drips, or runs) provided fluid does not contaminate MRGB rubber mounts. Verify servo input rod end/clevis area is clean; cleanse area with non-residue, non-alcoholic solvent as required. Verify approximately 0.040 inch total free-play at servo valve input. Inspect rod ends per § 2.120. Verify valve clearance to surrounding structure while flight controls are moved through full range of travel. Inspect condition and verify security of scissors at upper clevis of servos. Inspect clevis security and torque stripe per Figure 2-7.

**CAUTION**  
Use LPS PreSolve to clean hydraulic parts. Do not use alcohol.

**Aft Hydraulic Servo:** Inspect condition; verify no obvious defects. Hydraulic fluid seepage is permissible ("seepage" is evidence of fluids without flow, drips, or runs) provided fluid does not contaminate MRGB rubber mounts. Verify servo input rod end/clevis area is clean; cleanse area with non-residue, non-alcoholic solvent as required. Verify approximately 0.040 inch total free-play at servo valve input. Inspect rod ends per § 2.120. Verify valve clearance to surrounding structure while flight controls are moved through full range of travel. Inspect clevis security and torque stripe per Figure 2-7.

**Hydraulic-Servo Absorbent Pad (Recent Servos Only):** If installed, examine white absorbent pad(s); replace pad if damaged. If pad is discolored, remove pad from tray, then use a roller to squeeze out absorbed fluid, or replace pad. Clean tray & install pad.

**Aft Hydraulic Servo Supports:** Inspect RH and LH support rod ends per § 2.120. Inspect attachment to sheet metal; verify no cracks. Verify security.

**Hydraulic Lines & Fittings:** Inspect condition. Verify valve clearance to surrounding structure while flight controls are moved through full range of travel. Verify security and no leakage. Verify minimum 0.25 inch clearance between pump hoses and aux fuel tank.

**Fasteners and Torque Stripes:** Inspect condition and verify security of all fasteners. Renew deteriorated torque stripes per Figure 2-1.

2.410 Inspection Procedures and Checklist (continued)

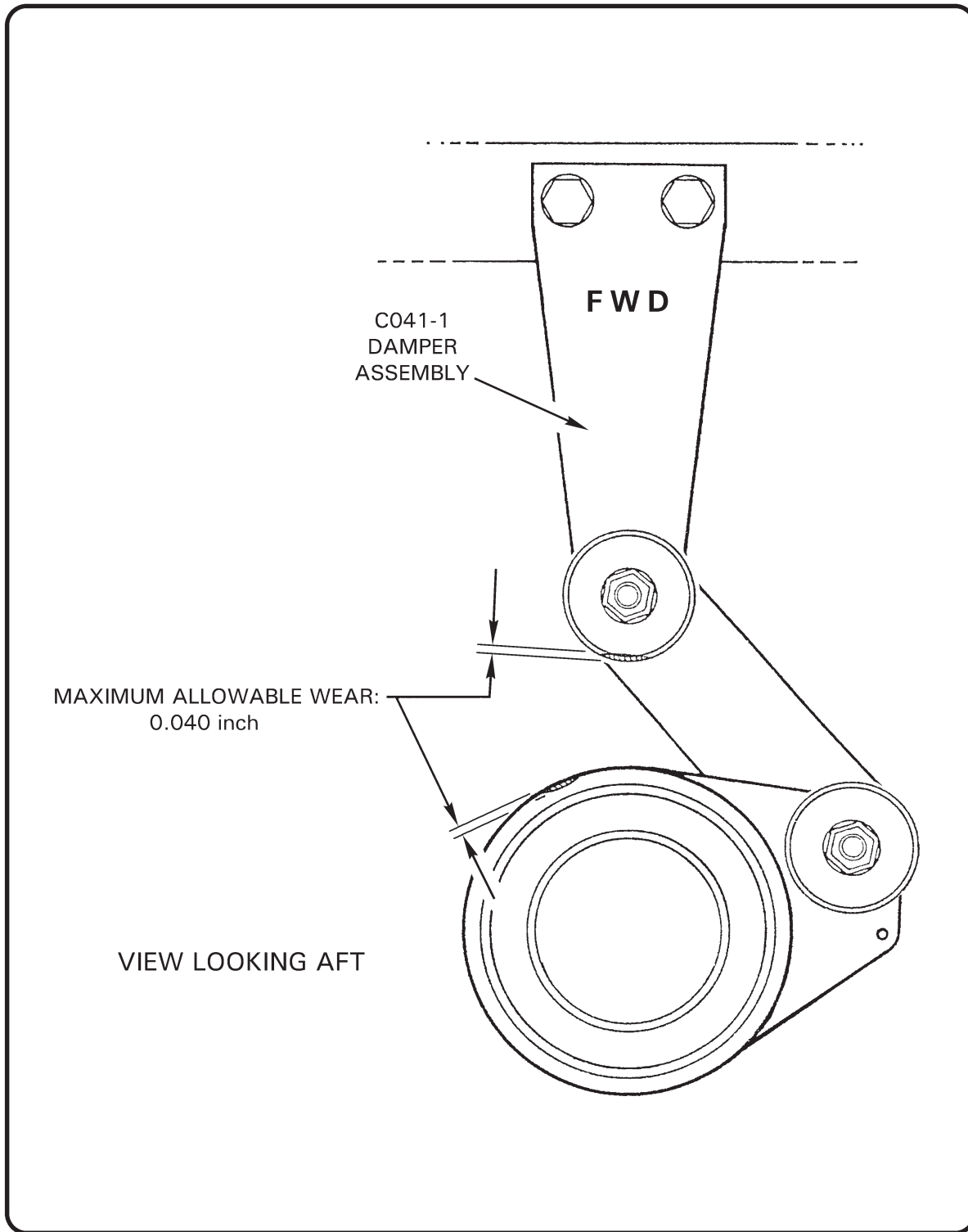

FIGURE 2-8 TAIL ROTOR DRIVE SHAFT DAMPER BEARING INSPECTION

2.410 Inspection Procedures and Checklist (continued)**8. Remove Tailcone Plugs (8A) & Aft Plastic Cover (8B)****NOTE**

Aft plastic cover (8B) is secured with two MS27039C0806 screws on Rev L and subsequent tailcones. On Rev K and prior tailcones ensure screws securing plastic cover are short enough to prevent interference in aft flex plate area.

**Tail Rotor Drive Shaft Assembly:** Examine accessible portion through inspection holes with inspection light and mirror. Verify no cracks, corrosion, or fretting in fore and aft bonded sleeves. Verify no evidence of drive shaft contact with tailcone bays. Verify no bends, bowing, dents, cracks, or corrosion. Perform tail rotor drive shaft runout per § 7.340. Verify proper installation, security, and operating clearance.

---

**CAUTION**

Bends, bowing, dents, cracks and corrosion are cause for immediate replacement of tail rotor drive shaft.

**Tail Rotor Push-Pull Tube & Forward Bellcrank:** Examine accessible portion through inspection holes with inspection light and mirror. Inspect condition per § 2.121. Verify no nicks, scratches, dents, cracks, or corrosion. Inspect rod end bearings per § 2.122; verify rod ends are centered and palnut and jam nut are tight. Check witness holes for proper thread engagement. Inspect bellcrank and bellcrank mount for nicks, scratches, dents, cracks, or corrosion. Inspect spherical bearings per § 2.122. Verify proper installation, security, and operating clearance. Verify tail rotor guard mounting screw shanks clear push-pull tube.

---

**Tail Rotor Drive Shaft Damper Assembly:** Verify no obvious damage. Verify integrity of bearing seals. Inspect bearing housing for excessive wear (see Figure 2-8). Verify bearing's inner race-to-drive shaft torque stripe is intact and no evidence of bearing slippage. Verify proper orientation, security, and smooth operation.

---

**Aft Flex Plate (refer to Figure 2-5):** Inspect condition. Verify no obvious damage. If fretting is detected, replace flex plate. Verify bonded washers are installed on both sides of each flex plate arm. Verify security and operating clearance.

---

**Tail Rotor Drive Shaft Aft Yoke:** Using inspection hole, check yoke for cracks, fretting, and corrosion.

---

2.410 Inspection Procedures and Checklist (continued)

**8. Remove Tailcone Plugs (8A) & Aft Plastic Cover (8B)**

**Tailcone Interior:** Inspect condition. Verify no cracks in damper mount angle. Verify wear at push-pull tube & bulkhead bushing (6 places) is not excessive. Remove debris. \_\_\_\_\_

**Tailcone Exterior:** Inspect condition. Verify drain hole in each bay is clear. Verify no cracks at antenna mounts and battery attachment (if on tailcone). \_\_\_\_\_

**Tailcone Battery (if installed):** Inspect condition. Verify no debris between battery box cover and tailcone. Verify security. \_\_\_\_\_

**F050-2 Horizontal Stabilizer (if installed):** Inspect condition. Verify security. \_\_\_\_\_

**Strobe Light:** Inspect lens and strobe light mount for cracks, loose rivets, and security. If split red/clear lens is installed, verify clear half of lens faces aft. \_\_\_\_\_

**Antennas:** Inspect condition. Verify no cracks where antennas mount to tailcone. Verify security. \_\_\_\_\_

**Tailcone Attachment:** Inspect condition and security of four bolts attaching tailcone to upper frame. \_\_\_\_\_

**Empennage:** Inspect condition. Verify no evidence of tail skid strike. Verify drain holes in lower vertical stabilizer and tail skid are clear. Verify proper installation and security. \_\_\_\_\_

**Tail Rotor Guard:** Inspect condition. Verify no cracks or corrosion at attach points. Verify security. \_\_\_\_\_

**Float Stabilizer (if installed):** Inspect condition and security. \_\_\_\_\_

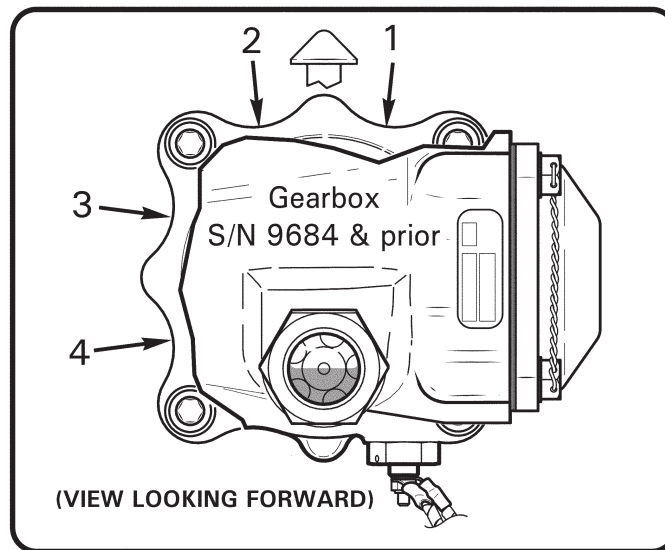

FIGURE 2-8A TRGB INPUT CARTRIDGE INSPECTION

2.410 Inspection Procedures and Checklist (continued)**9. Tail Rotor Gearbox and Tail Rotor**

**Input Shaft Yoke:** Inspect flange and weld for cracks and corrosion. \_\_\_\_\_

**Input Seal:** Inspect for leakage. \_\_\_\_\_

**Gearbox:** Inspect general condition. Look for leakage. Check oil quantity and cleanliness through sight gage and adjust or flush as required. Check gearbox-to-tailcone mounting security. Inspect output shaft for nicks, scratches and corrosion. Check safety wire on applicable gearbox bolts. Check Telatemp. Gearbox S/Ns 9684 & prior: using 10X magnification, visually inspect four curved surfaces on input cartridge per Figure 2-8A; if cracking is detected, remove gearbox from service and perform C148 Bulkhead Inspection per § 2.595. \_\_\_\_\_

**NOTE**

At 500 hours time-in-service or annually, whichever occurs first, remove chip detector and clean varnish from detector's magnetic probe and adjacent metal body (a toothbrush dampened with solvent works well). Also, drain and flush gearboxes at intervals not to exceed 500 hours time-in-service (refer to § 1.101).

**Pitch Control Assembly and C121-17 Push-Pull Tube:** Check pitch control assembly for free movement throughout its entire range and for looseness on output shaft (0.25 inch maximum rotational play measured at pitch link attach bolt). Inspect bellcrank for cracks and ensure free movement. Pay special attention to spherical bearing atop stud protruding from underside of pitch control; it is permissible to have a single radial crack in the spherical bearing ball. Inspect aft end of C121-17 push-pull tube for cracks and check rod end for excessive looseness (refer to R44 SB-43A). \_\_\_\_\_

**Pitch Links:** Check rod ends for excessive looseness. If equipped with one-piece pitch links, disconnect and rotate inboard end outboard as required to obtain maximum service life. Additionally, an optional A215-012 o-ring may be installed on A115-1 spacer under both bolt heads at pitch control. \_\_\_\_\_

**Tail Rotor Blades:** Confirm blades are P/N C029-3 Rev R or subsequent. Inspect blade surfaces and verify no nicks, scratches, cracks, corrosion, voids, debonding, or excessive erosion. Verify tail rotor blade root fitting bearings are not fretting or loose; loose bearing outer race in root fitting requires blade replacement. Verify blades cone toward gearbox. Perform tail rotor blade care per § 30-37. \_\_\_\_\_

2.410 Inspection Procedures and Checklist (continued)

**9. Tail Rotor Gearbox and Tail Rotor**

**Hub Plates and Hub:** Inspect for cracks and corrosion, paying special attention to areas around blade and hub mounting bolts. Ensure teeter hinge bearing outer races move with hub and bearing inner balls and retaining nut and bolt remain stationary when hub is teetered. Hub should move freely on bearings without stiffness or jerkiness. Check teeter hinge bearings for excessive play. For elastomeric bearings inspect per § 2.125. \_\_\_\_\_

**Fasteners and Torque Stripes:** Inspect condition and verify security of all fasteners. Renew deteriorated torque stripes per Figure 2-1. \_\_\_\_\_

**10. Open Mast Fairing (9)**

**Mast Fairing:** Inspect condition, especially where stiffeners intersect ribs. \_\_\_\_\_

**Lower Swashplate Scissors:** Inspect condition of scissors. Check rod end and bearing play. Check jam nut. \_\_\_\_\_

**Vertical Push-Pull Tubes:** Inspect for general condition and corrosion. For manual controls, inspect push-pull tube sleeves at rollers and guide. \_\_\_\_\_

**Rod Ends:** Check push-pull tube rod ends per § 2.120. \_\_\_\_\_

**Plastic Rollers and Guide (manual controls):** Inspect plastic rollers and guide for cleanliness, security, and deterioration. \_\_\_\_\_

**Pitot Tube:** Inspect pitot line and tube, giving special attention to connecting area, for bending, cracking and kinking. Verify pitot tube elbow drain hole is unobstructed. \_\_\_\_\_

**Fuel Tank Vents:** Inspect condition and security of fuel tank vent tube clamps. Ensure pitot line is not chafing fuel vent tubes. Check tube connections. Verify tubes are unobstructed and are not kinked, pinched, or chafing. \_\_\_\_\_

**Mast Fairing Ribs:** Inspect for cracks especially around mast tube attachments. \_\_\_\_\_

**11. Rotor Hub Area**

**Swashplate Lower Scissors:** Inspect condition. Inspect rod ends per § 2.120. Verify security. \_\_\_\_\_

**Swashplate Upper Scissors:** Inspect condition. Inspect rod ends and spherical bearings per § 2.120. Measure scissors play per Figure 2-9. Observe scissor linkage while having someone raise and lower collective. Verify bolt, journals (or spherical bearing balls and spacers), and arm rotate together at each scissor linkage pivot. Verify operating clearance. \_\_\_\_\_

2.410 Inspection Procedures and Checklist (continued)

**11. Rotor Hub Area (continued)**

**Swashplate Slider Tube:** Inspect condition. Verify no cracks at rivet holes or corrosion on base. Verify no damage to, or wear through, anodized tube surface. \_\_\_\_\_

**Remove Swashplate Boot Lower Ty-rap:** Lift boot from swashplate. Using an inspection mirror, inspect area between main rotor drive shaft and inside of slider tube. Verify no corrosion and no debris. Verify no boot damage. \_\_\_\_\_

**Swashplate:** Inspect condition. Verify 0.020 inch maximum radial play between swashplate ball and slider tube. Rotate rotor by hand and verify operating clearance and no rough or dry bearings. \_\_\_\_\_

**Swashplate Tilting Friction:** Observe swashplate ball from below and have someone move collective stick slowly up & down. Verify swashplate ball immediately moves with swashplate when swashplate reverses direction. Movement of swashplate without attendant ball movement indicates axial play between ball and swashplate; adjust swashplate tilting friction per § 8.413. \_\_\_\_\_

Intentionally Blank

2.410 Inspection Procedures and Checklist (continued)

**11. Rotor Hub Area (continued)**

**Install Swashplate Boot Lower Ty-rap:** Verify correct boot position and security and no boot damage. \_\_\_\_\_

**Hub:** Inspect condition. Verify no nicks, scratches, gouges, or corrosion. If main rotor imbalance is suspected, check teeter and coning hinge friction per § 28-32. Verify no brown or black residue (indicates bearing wear). \_\_\_\_\_

**Hinge Bolts:** Inspect condition. Verify cotter pins are in place and secure. Verify bolt heads and nuts are torque striped to thrust washers. \_\_\_\_\_

**Pitch Links and Rod Ends:** Inspect condition. Inspect rod ends per § 2.122, including centering. Verify security, including jamnut tightness and proper safety wiring. \_\_\_\_\_

**Fasteners and Torque Stripes:** Inspect condition and verify security of all fasteners. Renew deteriorated torque stripes per § 2.140. \_\_\_\_\_

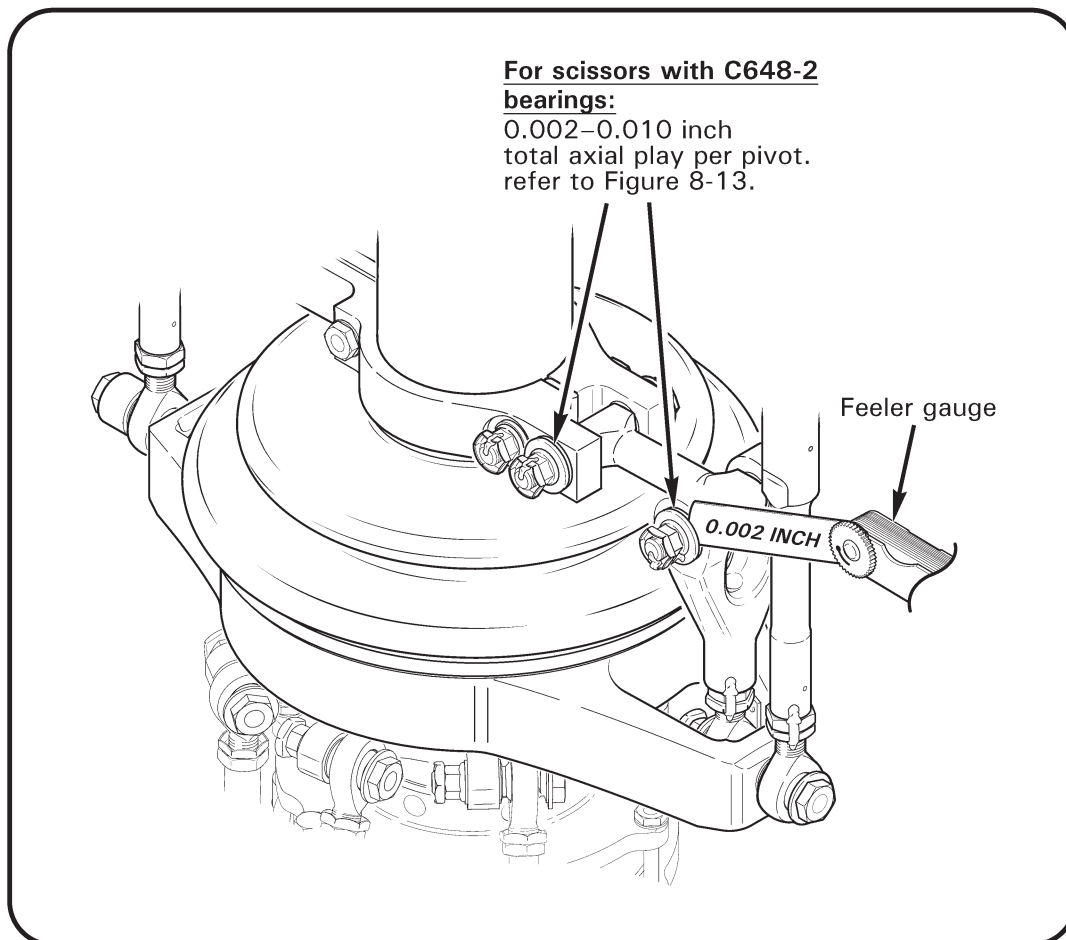

FIGURE 2-9 MEASURING UPPER SWASHPLATE SCISSOR AXIAL CLEARANCE

2.410 Inspection Procedures and Checklist (continued)

**12. Main Rotor Blades**

**Boots:** Inspect condition. Verify no boot damage or oil leakage. Verify proper boot position and security. Verify sufficient clearance from hub assembly through full control travel.

**Blade Spindles & Root Fittings:** Inspect area for damage per § 28-43. Verify proper installation and security of visible fasteners. Renew deteriorated torque stripes per Figure 2-1.

**Main Rotor Blade Tip Maintenance:** Perform main rotor blade tip maintenance per § 28-60.

**Main Rotor Blade Inspection:** Inspect skins and doublers for scratches and corrosion per § 28-41. Inspect blades for dents and local deformations per § 28-42 and for voids per § 28-44. As required, wax blades with soft cleaning cloths using carnauba-type wax (such as SC Johnson® Paste Wax). Ensure tip cover and blade tip drain holes are unobstructed.

**WARNING**

**Structural damage may occur if compressed air is applied to blade tip drain holes.**

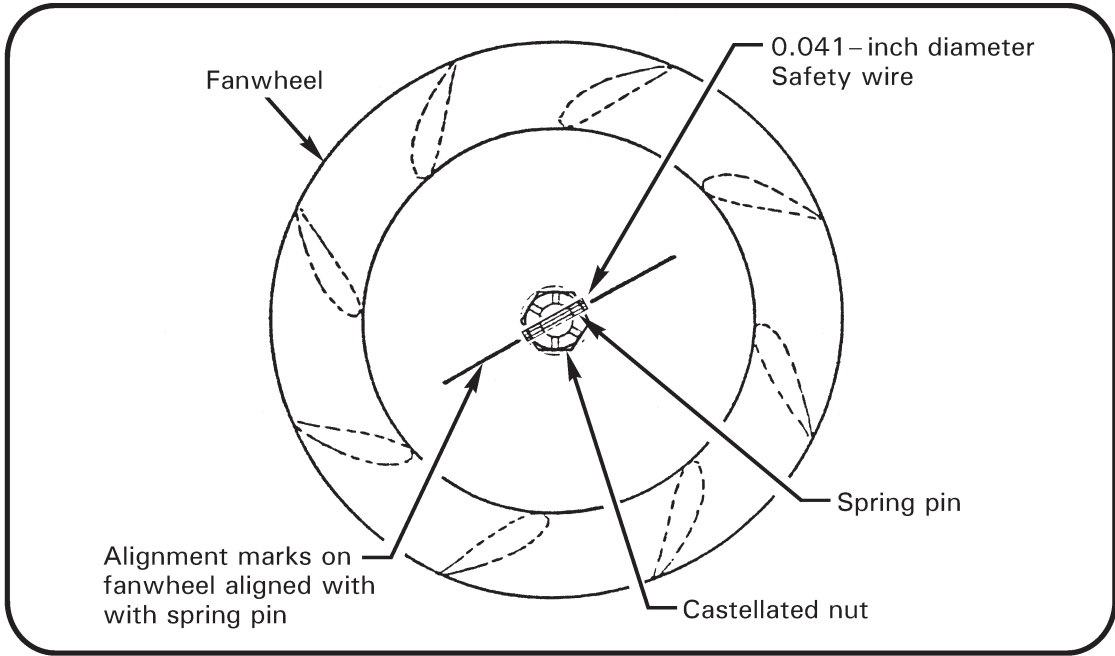

**FIGURE 2-10 FANWHEEL ALIGNMENT MARKS**

2.410 Inspection Procedures and Checklist (continued)

**13. Scroll Area**

**Fanwheel Assembly:** Clean and inspect fanwheel assembly for cracks and corrosion. Check leading edge of vanes for damage. Verify spring pin and fanwheel alignment marks are aligned (see Figure 2-10); remove fanwheel and inspect mating surfaces for damage if misalignment is evident.

**Fiberglass Scroll:** Inspect fiberglass scroll for cracks and contact marks from fanwheel. Inspect flexible seal around scroll inlet for any rips or damage. Inspect vane assembly in right upper scroll for damage. Verify drain hole is unobstructed.

**Scroll Metal Inlet Lips & Gap:** Verify 0.030 / 0.090 inch gap between lips and fanwheel inlet (elongate lip attach holes as required to adjust gap).

**Lower Bearing Brackets:** Refer to Figure 2-11. Visually inspect A185 brackets and attaching screws/rivets for evidence of fretting or looseness. If evidence of looseness is found, contact RHC Technical Support for repair instructions. On lower A185 bracket, apply torque seal in a horizontal stripe across both outboard screws/rivets to lower scroll to facilitate future inspections.

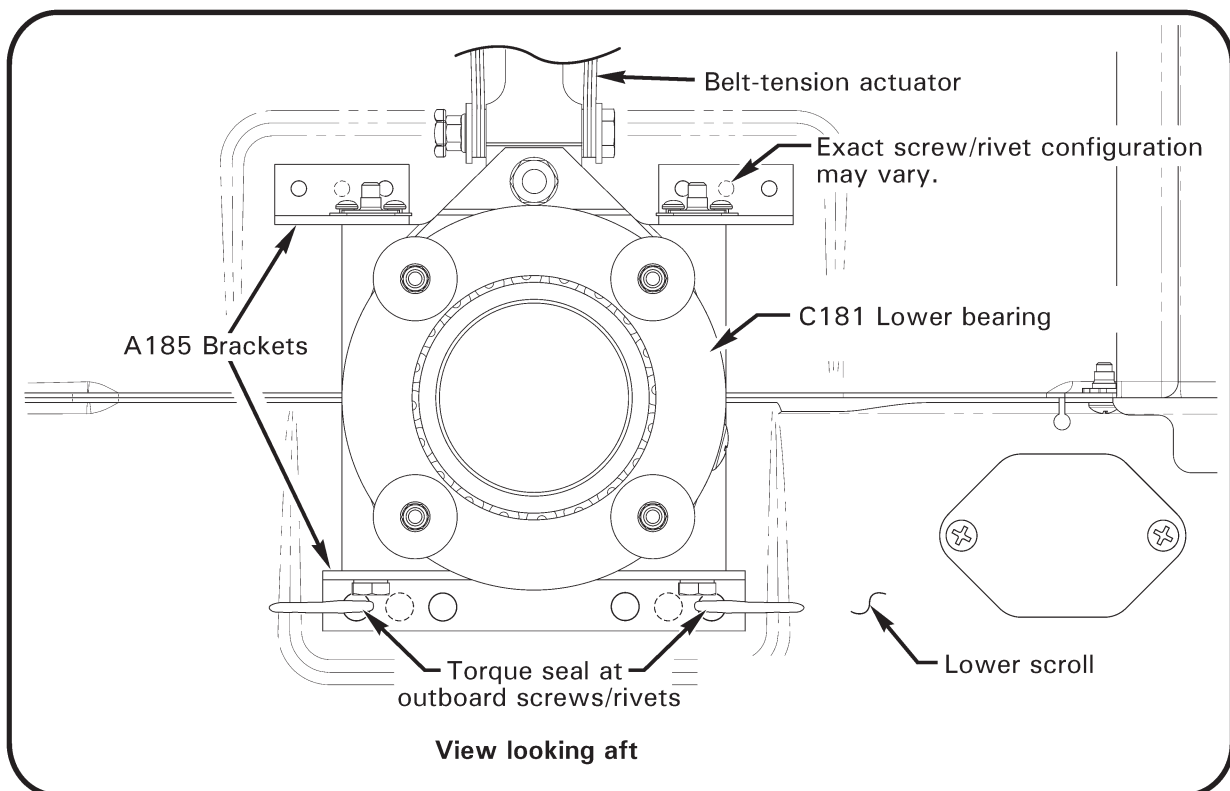

**FIGURE 2-11 ACTUATOR LOWER BEARING A185 BRACKETS**

2.410 Inspection Procedures and Checklist (continued)

**14. Engine**

Refer to § 1.101. Refer to Lycoming Operator’s Manual (P/N 60297-10 sections 4 and 5), Lycoming SI 1080, and applicable engine component manufacturer’s maintenance publications for 100-hour or annual inspection and service procedure. \_\_\_\_\_

**Engine Cooling Panels:** Inspect condition. Pay particular attention to panel(s) mounting oil cooler(s) and panel attached to alternator cooling hose. Verify no cracks or missing or loose fasteners. Verify security. \_\_\_\_\_

**Alternator & Pulley:** Inspect condition. Verify steel pulley (use magnet); aluminum pulley is not approved. Verify security. Verify electrical wiring security. \_\_\_\_\_

**Alternator Belt:** Inspect condition. Replace belt if there are any cracks, missing teeth, or delamination. Check tension per Lycoming Service Instruction 1129 (latest revision). Verify proper belt alignment. \_\_\_\_\_

**Emergency Spare Alternator Belt:** Remove if installed. \_\_\_\_\_

**Alternator Cooling Hose:** Inspect condition. Verify no obstructions or holes. Verify security. \_\_\_\_\_

**Air Conditioning Refrigerant Lines (if installed):** Verify security, no damage, and clearance to adjacent structure. Verify dust caps installed on servicing fittings at vertical firewall. \_\_\_\_\_

**Air Conditioning Compressor (if installed):** Verify security. \_\_\_\_\_

**Air Conditioning Compressor Drive Belt (if installed):** Inspect condition. Verify 4.5/5.5 pounds force applied at mid-span of belt causes 0.11/0.17 inch belt deflection; adjust as required. \_\_\_\_\_

**Muffler Elbow & Tailpipe Shields:** Verify no cracks in shields and shield attaching brackets. Verify clamp security. \_\_\_\_\_

2.410 Inspection Procedures and Checklist (continued)

**15. Exhaust System**

**Muffler:** Remove muffler heater shroud screws, and open shroud. Inspect muffler outer wall for cracks, deformation, and ruptures. Pay particular attention to tailpipe and riser attachment areas, welds, clamps, supports, riser flanges and gaskets. Pressurize muffler with low pressure air and inspect for leakage. Close and secure heater shroud.

**16. Landing Gear**

**Skids and Shoes:** Inspect left and right landing gear skids and skid shoes; minimum allowable shoe thickness is 0.05 inch. Verify drain holes are open (not applicable to float landing gear).

**Struts and Elbows (open fairings if installed):** Inspect for cracks and corrosion, especially at elbow joints. Inspect weld area at bottom of strut for cracks.

**Landing Gear Fairings (if installed):** Inspect for cracks and loose rivets. Verify security.

**Crosstubes:** Inspect, especially at elbow joints, for cracks and corrosion. With helicopter on level ground, measure distance from ground to tail skid. If dimension is less than 30 inches, one or both cross tubes must be replaced (see Chapter 5).

**Landing Gear Attach Points:** Check forward attach points for loose rivets, cracks, buckling, and fretting. Check bearing mounts for loose swages and worn bearings.

**Utility Floats (if installed):** Inspect for damage. Refer to applicable Pilot's Operating Handbook for proper inflation pressure.

**Pop-out Floats (if installed) Pressure Cylinder & Valve:** Inspect condition. Verify security. Verify pressure gage indicates correct pressure for ambient temperature; refer to placard on cylinder for limits.

**Pop-out Floats (if installed) Inflation Manifold:** Inspect condition. Verify no chafing or pinching of hoses, especially where hoses pass thru structure.

**Pop-out Floats (if installed):** Inspect condition of stowed floats. Verify no holes, cuts, tears, abrasion thru, or unraveling of, float covers. If cover damage is found, inflate and inspect floats. Verify all float cover snaps and hook-and-loop fasteners are properly secured. Verify float-to-skid attachment security.

**NOTE**

Annually apply A257-7 dry-film lubricant (see § 23-78) to float cover snap mating surfaces. Annually perform § 5.630 leak check. Every three years, perform § 5.640 emergency inflation test.

2.410 Inspection Procedures and Checklist (continued)

**17. Cabin**

**General interior:** Inspect condition. Verify general cleanliness of cabin and seat compartment interior. Verify no loose objects or equipment, which could foul controls, or injure occupants in a hard landing. Verify legibility of placards and markings. Verify serviceable condition of switches, knobs, handles, and other controls. \_\_\_\_\_

**Rear Seat-Bottom Suspension Straps:** Inspect condition and security. \_\_\_\_\_

**Seat Belts and Shoulder Harnesses:** Inspect for fraying and broken stitching. Check inertia reels for proper operation by pulling harness quickly to verify locking function. Check buckles for proper operation. Check belt and reel attach points for security. \_\_\_\_\_

<p><b>NOTE</b></p> <p>TSO tag not required on factory installed harnesses.</p>
--

**Heated Seats (if installed):** Perform heated seats inspection per § 15.240 Part D. \_\_\_\_\_

**Cyclic Guard (if installed):** Inspect condition of cyclic guard. Inspect all welds for cracks. Verify no corrosion. Verify security and proper operation. \_\_\_\_\_

**Cockpit Camera (if installed):** Inspect condition. Verify camera lens is clean. Perform functional check per § 37-140 Part D. \_\_\_\_\_

**Exterior:** Inspect condition. Inspect cabin exterior for nicks, scratches, dents, cracks, corrosion, fretting, or loose rivets. Loose rivets may be indicated by cracked paint and/or black residue around heads. Verify general cleanliness. \_\_\_\_\_

**Windshields & Windows:** Inspect condition. Verify no significant UV yellowing. Minor defects or imperfections that do not impair pilot visibility are acceptable. Refer to § 27-30 for damage and repair limits. Verify security. \_\_\_\_\_

**Yaw String:** Inspect condition. Verify minimum string length is 3 inches on each side of clip. Verify security. \_\_\_\_\_

**Doors:** Inspect for cracks around hinges and latches. Check vents for operation. Ensure hinge pins are secured with cotter pins. Check tightness of hinge mounting screws. Verify proper operation of door latching and locking mechanisms. \_\_\_\_\_

**Skin:** Inspect skin for damage. Inspect for loose rivets, indicated by cracked paint and/or black residue around heads. \_\_\_\_\_

2.410 Inspection Procedures and Checklist (continued)

**17. Cabin (continued)**

**Static Ports:** Inspect static ports for obstructions. If fixed utility floats are installed, verify air dam installed aft of both static ports. \_\_\_\_\_

**Left & Right Navigation Lights:** Inspect condition. Verify no cracks where right and left navigation lights mount to fuselage. Verify red left, green right, lens cleanliness, clarity, and security. Verify proper operation. \_\_\_\_\_

**Landing & Taxi Lights:** Inspect condition. Verify lens cleanliness, clarity, and security. Verify proper operation. \_\_\_\_\_

**Landing Light Retainer & Support:** Inspect condition. Verify no cracks where retainer mounts to support. Verify security. \_\_\_\_\_

**Chin Drains (R44 Clipper):** Verify no obstructions. \_\_\_\_\_

**18. Special Equipment (if installed)**

**Peak Beam Searchlight:** Check for proper operation. Align beams by focusing both lights to smallest spot possible and shining against a wall at least 100 feet away. Verify both spots hit same point within one foot. \_\_\_\_\_

**Nose Gimbal and Monitors:** Turn power on and verify infrared units complete cool down sequence in manufacturer’s recommended time. Verify gimbal steers smoothly in azimuth and elevation. Check focus and zoom of infrared/video. Check for clear images on monitors. Verify retractable monitor retracts without interference. \_\_\_\_\_

**Spectrolab Searchlight:** Verify light starts and cooling fan operates. Verify searchlight steers smoothly in azimuth and elevation. For slaved units, turn on slaving and verify light follows nose gimbal approximately. \_\_\_\_\_

**FM Radios:** Verify radios transmit and receive properly and control head programs radios properly. \_\_\_\_\_

**Video Tape Recorder:** Verify all video tape recorder modes operate properly and remote control correctly controls modes. \_\_\_\_\_

**Overhead Light:** Verify overhead light on/off. \_\_\_\_\_

**Transmit and Intercom Switches:** Verify proper operation of special transmit and intercom switches. \_\_\_\_\_

**Talent Light:** Verify talent light on/off, acceptable friction. \_\_\_\_\_

**Micro Cameras:** Verify all micro cameras are selectable from video switcher and produce focused, upright images on monitors. \_\_\_\_\_

**TV Tuner:** Verify TV tuner receives broadcasts (video clear on monitors, audio clear in headset). \_\_\_\_\_

2.410 Inspection Procedures and Checklist (continued)

**18. Special Equipment (if installed) (continued)**

**Microwave Antenna:** Verify omnidirectional microwave antenna extends/retracts properly. Verify up/down indicator lights function properly. \_\_\_\_\_

**Electromagnetic and Radio Frequency Interference:** With all special equipment turned on, check for EMI/RFI with tach, COM, intercom, compass, or other systems. \_\_\_\_\_

**19. Life-Limited Parts, Additional Component Maintenance, ADs, & SBs**

**Life-Limited Parts:** Refer to helicopter maintenance records and § 3.300. Replace life-limited parts as required. Verify components installed have sufficient time remaining for projected operations. \_\_\_\_\_

**Airworthiness Directives:** Verify applicable airframe, engine, and accessory Airworthiness Directives (ADs) have been performed according to AD compliance procedures. Some aircraft may be affected by ADs that require recurring inspections at less than 100-hour or annual intervals. Recent U.S. Airworthiness Directives are available online at [www.faa.gov](http://www.faa.gov).

**Service Bulletins:** Verify applicable airframe, engine, and accessory Service Bulletins (SBs) have been complied with according to manufacturers' instructions. Some aircraft may be affected by SBs that require recurring inspections at less than 100-hour or annual intervals. RHC Service Bulletins are available online at <https://robinsonheli.com>, under the Publications tab. \_\_\_\_\_

**20. Required Documents and Placards**

**Documents:** Check that required documents (Airworthiness Certificate, Registration, applicable Radio Station License, applicable Pilot's Operating Handbook, Equipment List/Weight & Balance Data) are on board, legible, and current. \_\_\_\_\_

**Placards:** Verify required placards are properly installed, legible, and current. Refer to applicable Pilot's Operating Handbook Section 2 for placard requirements. \_\_\_\_\_

**21. Inspection and Access Covers**

**Foreign Objects Removed:** Verify all tools, loose hardware, rags, and other foreign objects are removed from helicopter. \_\_\_\_\_

**Covers Closed and Secure:** Install/close all inspection and access covers removed in preceding steps. Verify security of all access covers. \_\_\_\_\_

**Clipper I Air Box Sealed:** Ensure air box cover perimeter is sealed with aluminum tape (Clipper I models only). \_\_\_\_\_

2.410 Inspection Procedures and Checklist (continued)**22. Maintenance Records**

**Maintenance Records:** Verify maintenance records are accurate, legible, and complete. Enter maintenance performed (such as part replacement, equipment adjustments, servicing, and lubrication) and inspection data. Data must include a description of (or reference to data acceptable to the Administrator) the work performed, date, helicopter total time in service, signature, certificate type and certificate number of person approving aircraft for return to service. \_\_\_\_\_

**SHEAVE ALIGNMENT LEFT:** \_\_\_\_\_

**SHEAVE ALIGNMENT RIGHT:** \_\_\_\_\_

**TRDS RUNOUT:** \_\_\_\_\_

**CHECKLIST COMPLETE:**

Mechanic's signature: \_\_\_\_\_ Date: \_\_\_\_\_

Intentionally Blank