

**CHAPTER 8**

**FLIGHT CONTROLS**

<u>Section</u>	<u>Title</u>	<u>Page</u>
8.000	Flight Controls . . . . .	8.1
8.001	Introduction . . . . .	8.1
8.002	Description . . . . .	8.1
8.003	Hydraulic Flight Controls . . . . .	8.1
8.004	Hydraulic Pump Description . . . . .	8.1A
8.005	Hydraulic Reservoir Description . . . . .	8.1A
8.006	Hydraulic Servo Description . . . . .	8.1B
8.100	Cyclic Controls . . . . .	8.3B
8.110	Cyclic Assembly . . . . .	8.3B
8.111	Cyclic Assembly Removal . . . . .	8.3B
8.112	Cyclic Assembly Installation . . . . .	8.5
8.120	Cyclic Grip Assembly . . . . .	8.6
8.121	Cyclic Grip Assembly Removal . . . . .	8.6
8.122	Cyclic Grip Assembly Installation . . . . .	8.10
8.130	Longitudinal Cyclic Trim Elastic Cords (electric trim systems only) . . . . .	8.11
8.131	Elastic Cord Removal . . . . .	8.13
8.132	Elastic Cord Installation . . . . .	8.14
8.140	Lateral & Longitudinal Cyclic Trim Assemblies (electric trim systems only) . . . . .	8.15
8.141	Lateral Cyclic Trim Assembly Removal . . . . .	8.15
8.142	Lateral Cyclic Trim Assembly Installation . . . . .	8.16
8.143	Longitudinal Cyclic Trim Assembly Removal . . . . .	8.16
8.144	Longitudinal Cyclic Trim Assembly Installation . . . . .	8.17
8.150	Cyclic Friction Assembly . . . . .	8.19
8.151	Cyclic Friction Adjustment . . . . .	8.19
8.160	C121-7 Push-Pull Tube (electric trim systems only) . . . . .	8.19
8.161	C121-7 Push-Pull Tube Removal . . . . .	8.19
8.162	C121-7 Push-Pull Tube Inspection / Repair . . . . .	8.20
8.163	C121-7 Push-Pull Tube Sleeve Installation . . . . .	8.20
8.164	C121-7 Push-Pull Tube Sleeve Inspection . . . . .	8.21
8.165	C121-7 Push-Pull Tube Installation . . . . .	8.21
8.200	Collective Control . . . . .	8.24
8.210	Collective Stick Assembly . . . . .	8.24
8.211	Collective Stick Removal . . . . .	8.24
8.212	Collective Stick Installation . . . . .	8.24

**CHAPTER 8**

**FLIGHT CONTROLS (Continued)**

<u>Section</u>	<u>Title</u>	<u>Page</u>
8.213	Pilot-Adjustable Collective Friction Adjustment . . . . .	8.28
8.214	Fixed Collective Friction Adjustment . . . . .	8.28
8.220	Collective Spring Assembly (manual controls only) . . . . .	8.28
8.221	Collective Spring Removal & Servicing . . . . .	8.28
8.222	Collective Spring Installation . . . . .	8.30
8.223	Collective Spring Adjustment . . . . .	8.31
8.230	RPM Governor System . . . . .	8.32
8.231	Governor Controller Removal . . . . .	8.32
8.232	Governor Controller Installation . . . . .	8.32A
8.233	Governor Assembly Removal . . . . .	8.33
8.234	Governor Assembly Installation . . . . .	8.33
8.239	Governor Troubleshooting . . . . .	8.33A
8.300	Jackshaft and Support Struts . . . . .	8.34
8.310	Jackshaft . . . . .	8.34
8.311	Jackshaft Removal . . . . .	8.34
8.312	Jackshaft Installation . . . . .	8.34
8.320	Strut Assembly (Jackshaft Support) . . . . .	8.34
8.321	Jackshaft Strut Removal . . . . .	8.34
8.322	Jackshaft Strut Installation . . . . .	8.35
8.400	Swashplate and Main Rotor Pitch Links . . . . .	8.39
8.410	Swashplate . . . . .	8.39
8.411	Swashplate Removal . . . . .	8.39
8.412	Swashplate Installation . . . . .	8.39
8.413	Swashplate Tilting Friction Adjustment . . . . .	8.43
8.500	Tail Rotor Controls . . . . .	8.44
8.510	Tail Rotor Pedals . . . . .	8.44
8.511	Tail Rotor Pedal Removal . . . . .	8.44
8.512	Tail Rotor Pedal Installation . . . . .	8.45
8.520	C317 Bellcranks . . . . .	8.46
8.521	C317-2 Lower Forward Bellcrank Removal . . . . .	8.46
8.522	C317-2 Lower Forward Bellcrank Installation . . . . .	8.46
8.523	C317-1 Lower Aft Bellcrank Removal . . . . .	8.48
8.524	C317-1 Lower Aft Bellcrank Installation . . . . .	8.49
8.530	C316-1 Bellcranks . . . . .	8.49

**CHAPTER 8**

**FLIGHT CONTROLS (Continued)**

<u>Section</u>	<u>Title</u>	<u>Page</u>
8.531	Bellcrank Removal . . . . .	8.49
8.532	Bellcrank Installation . . . . .	8.50
8.540	A331-4 Intermediate Bellcrank . . . . .	8.50
8.541	Bellcrank Removal . . . . .	8.50
8.542	Bellcrank Installation . . . . .	8.50
8.550	A120-3 Aft Bellcrank . . . . .	8.51
8.551	Bellcrank Removal . . . . .	8.51
8.552	Bellcrank Installation . . . . .	8.51
8.560	C031-1 Pitch Control . . . . .	8.51
8.561	Pitch Control Removal . . . . .	8.51
8.562	Pitch Control Installation . . . . .	8.51
8.570	Tail Rotor Pitch Links . . . . .	8.52
8.571	Tail Rotor Pitch Link Removal . . . . .	8.52
8.572	Tail Rotor Pitch Link Installation . . . . .	8.52
8.600	C203 Yoke and A205 Fork Assemblies . . . . .	8.54
8.610	Bearing Removal . . . . .	8.54
8.615	C648-2 Bearing Installation . . . . .	8.54
8.620	B115-1 Bearing Installation . . . . .	8.54
8.700	Hydraulic Flight Controls . . . . .	8.61
8.710	Hydraulic Reservoir Removal . . . . .	8.61
8.720	Hydraulic Reservoir Installation . . . . .	8.61
8.730	Hydraulic Pump Removal . . . . .	8.62
8.740	Hydraulic Pump Installation . . . . .	8.63
8.750	Hydraulic Servo Removal . . . . .	8.64
8.760	Hydraulic Servo Installation . . . . .	8.65

Intentionally Blank

## CHAPTER 8

## FLIGHT CONTROLS

8.000 Flight Controls8.001 Introduction

This section covers removal and installation procedures for cyclic controls, collective controls, tail rotor controls, and related components.

**WARNING**

**Assembly of flight controls is critical and requires inspection by a qualified person. If a second person is not available, the installer must take a 5-minute break prior to inspecting flight control connections he has assembled.**

8.002 Description (see Figures 8-1 and 8-2)

Dual controls, which are removable on the left side, are standard equipment. All primary controls are actuated through push-pull tubes and bellcranks. Bearings used throughout the control system are either sealed ball bearings or have self-lubricated Teflon® liners.

R44 flight controls operate conventionally. The cyclic stick appears different, but the grip moves as in other helicopters. The cyclic grip is free to move vertically allowing the pilot to rest his forearm on his knee if he chooses. Electric trim-equipped aircraft include strain gages mounted to the cyclic stick to sense control forces, and electric trim motors at the base of the stick which automatically minimize these forces.

The collective stick is conventional with a twist grip throttle. When the collective control is raised, the engine throttle is opened automatically by an interconnecting linkage. Additionally, an electronic throttle governor adjusts throttle position to maintain RPM.

8.003 Hydraulic Flight Controls**WARNING**

**Except as instructed in this manual, service on the hydraulic system is limited to component removal and replacement.**

**CAUTION**

Cleanliness of hydraulic fluid is vital to proper system operation. Use only clean fluid from sealed containers and avoid contamination from dirty funnels, tubing, etc. Do not use alcohol to clean hydraulic components.

**NOTE**

Recent hydraulic servos include an absorbent pad. Any combination of servos with or without an absorbent pad is approved.

### 8.003 Hydraulic Flight Controls (continued)

The hydraulic flight control system consists of a pump mounted to the main rotor gearbox, a servo at each of the three push-pull control tubes supporting the main rotor swashplate, a reservoir assembly, interconnecting lines, A257-15 hydraulic fluid (see § 23-78). An elastic cord replaces the collective trim spring and balances the weight of the collective stick.

Figure 8-1A shows the hydraulic control system. A schematic diagram of the system is given in Figure 8-1B.

### 8.004 Hydraulic Pump Description

The R44 hydraulic system uses a single stage, positive displacement gear pump. The pump drive shaft is splined to a pinion gear which is driven by the main rotor gearbox ring gear. The pump gears are supported by needle bearings. The pump drive shaft is designed to shear to protect the main gearbox if pump were to seize. Dual seals prevent cross-contamination of gearbox and hydraulic fluids. A vent hole between the seals also acts as a drain to indicate if either seal has failed.

### 8.005 Hydraulic Reservoir Description

The reservoir assembly includes a filter, pressure relief valve, pump bypass solenoid, return shut-off valve, and ports to and from the pump and to and from the servos. Reservoir capacity is 1.3 pints. A sight glass for pre-flight fluid level checks is also provided along with a removable filler-vent to allow addition of fluid. A 1.25 inch diameter hose directs cooling air from the engine-driven fanwheel to the reservoir cooling fins.

The filter is a disposable cartridge rated at 10 microns (P/N AN6235-1A), to be replaced at intervals specified in Table 1 Scheduled Inspections (ref. § 1.101). Full-flow filtration is provided for all flow from the pump.

The pressure relief valve regulates system pressure to 450–500 psi. Since the pump provides enough flow to meet servo requirements during severe flight conditions, excess flow is available under normal flight conditions. The excess fluid flows through the pressure relief valve directly back into the reservoir.

The pump bypass solenoid allows the pilot to shut off hydraulic pressure to the servos. Switching off the hydraulics at the pilot's cyclic control grip energizes the solenoid, which opens a valve to the reservoir and depressurizes the system. Since electric power is only required to switch the system off, an electrical system failure does not affect hydraulic operation. The solenoid valve is provided primarily to allow pilot training with hydraulics off.

The return shut-off valve closes the return from the actuators whenever system pressure drops below 80 psi. The valve assures that the irreversible feature of the actuators functions properly by preventing hydraulic fluid from leaving the servos if system pressure is lost. The valve includes a thermal relief feature to prevent excessive pressure due to thermal expansion of the fluid.

### 8.006 Hydraulic Servo Description

The purpose of the servo is to provide output motion equivalent to pilot input motion without transmitting main rotor feedback forces to the pilot's controls. The clevis at the input end has an over-sized hole to allow pilot input to move the control valve while also providing a direct mechanical link if hydraulic pressure is lost. With hydraulic pressure, servo output immediately matches input. Absent hydraulic pressure, the servo input clevis allows 0.040 inch total travel ("freeplay") prior to causing servo output. An irreversible feature is included to reduce pilot control forces with hydraulics off. A 40-micron filter is located at the pressure port to prevent contamination during maintenance. The pressure and return ports are different sizes to prevent incorrect installation of hydraulic lines.

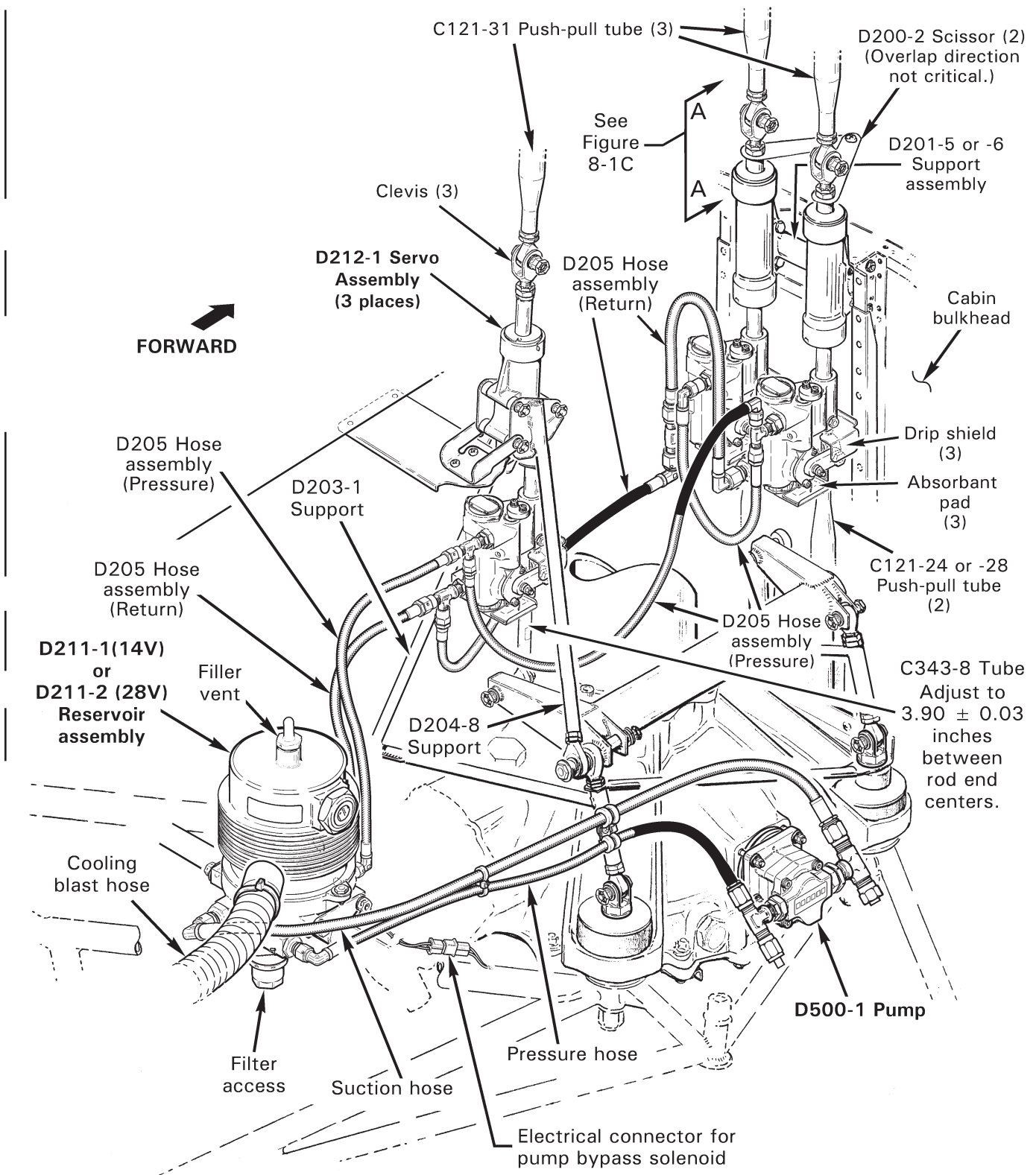
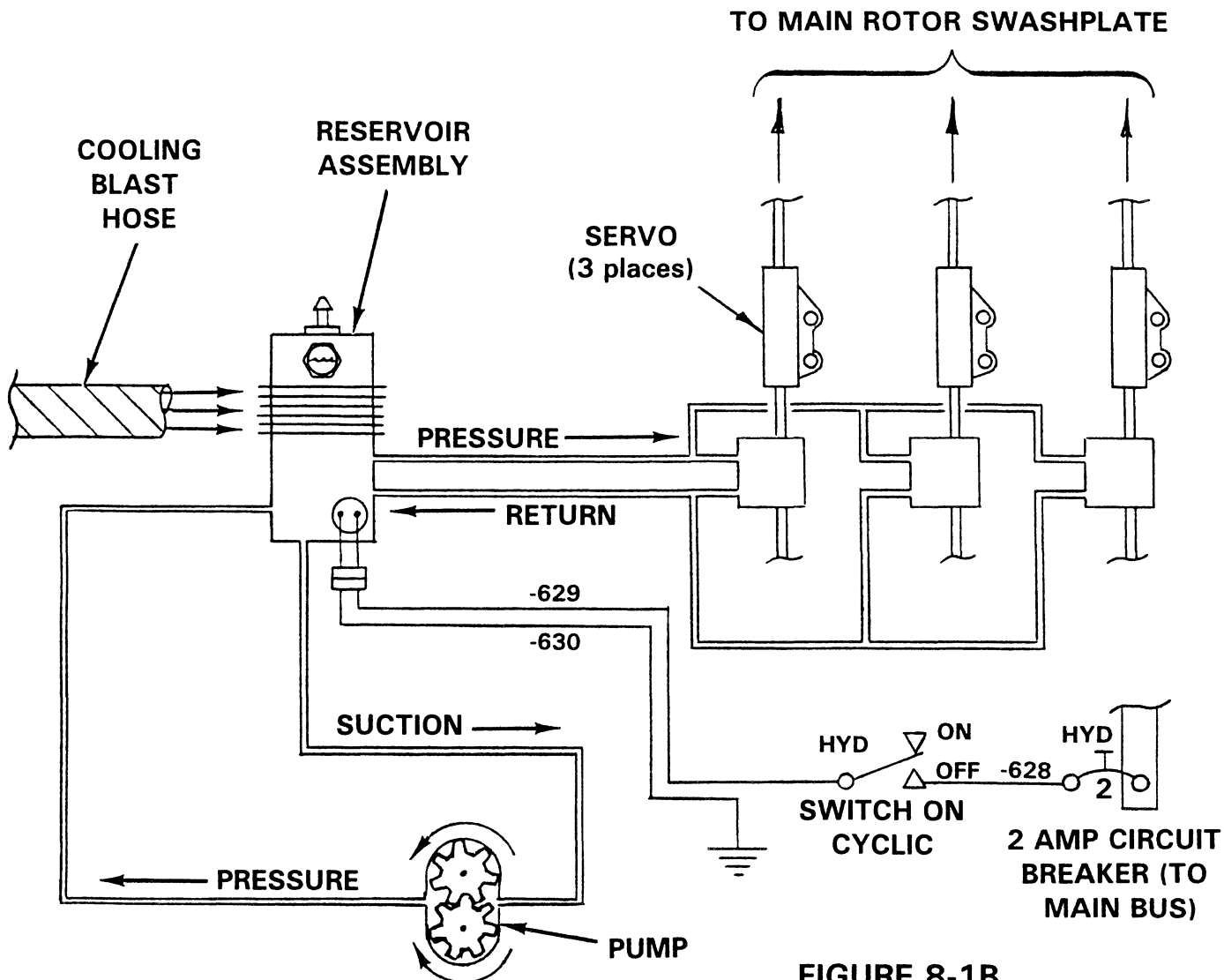
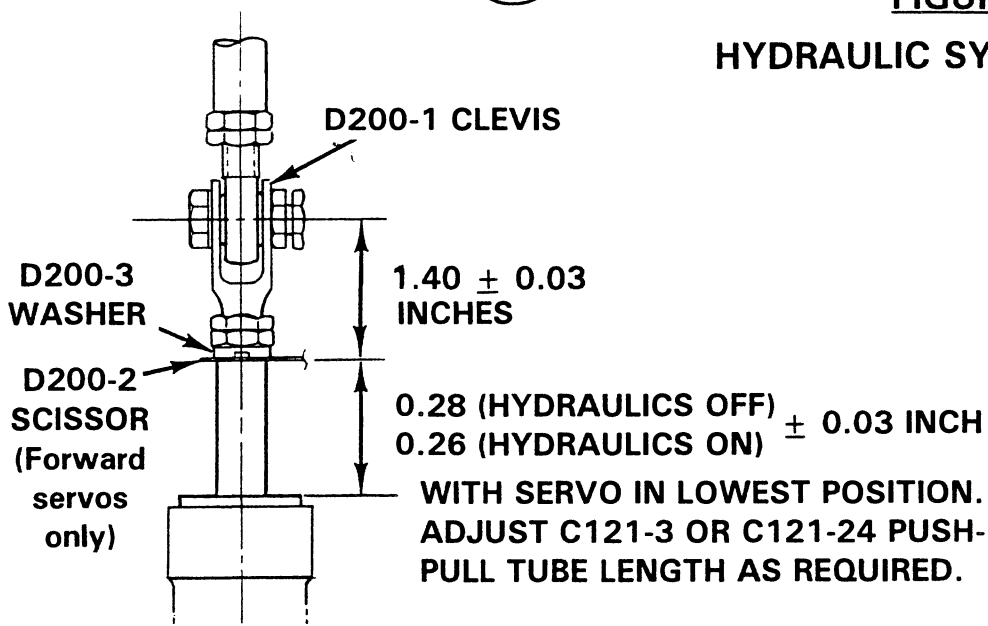

FIGURE 8-1A HYDRAULIC FLIGHT CONTROL SYSTEM



**FIGURE 8-1B**  
**HYDRAULIC SYSTEM SCHEMATIC**



**FIGURE 8-1C**  
**SERVO RIGGING**  
(Typical three places)

(View A-A from Figure 8-1A)

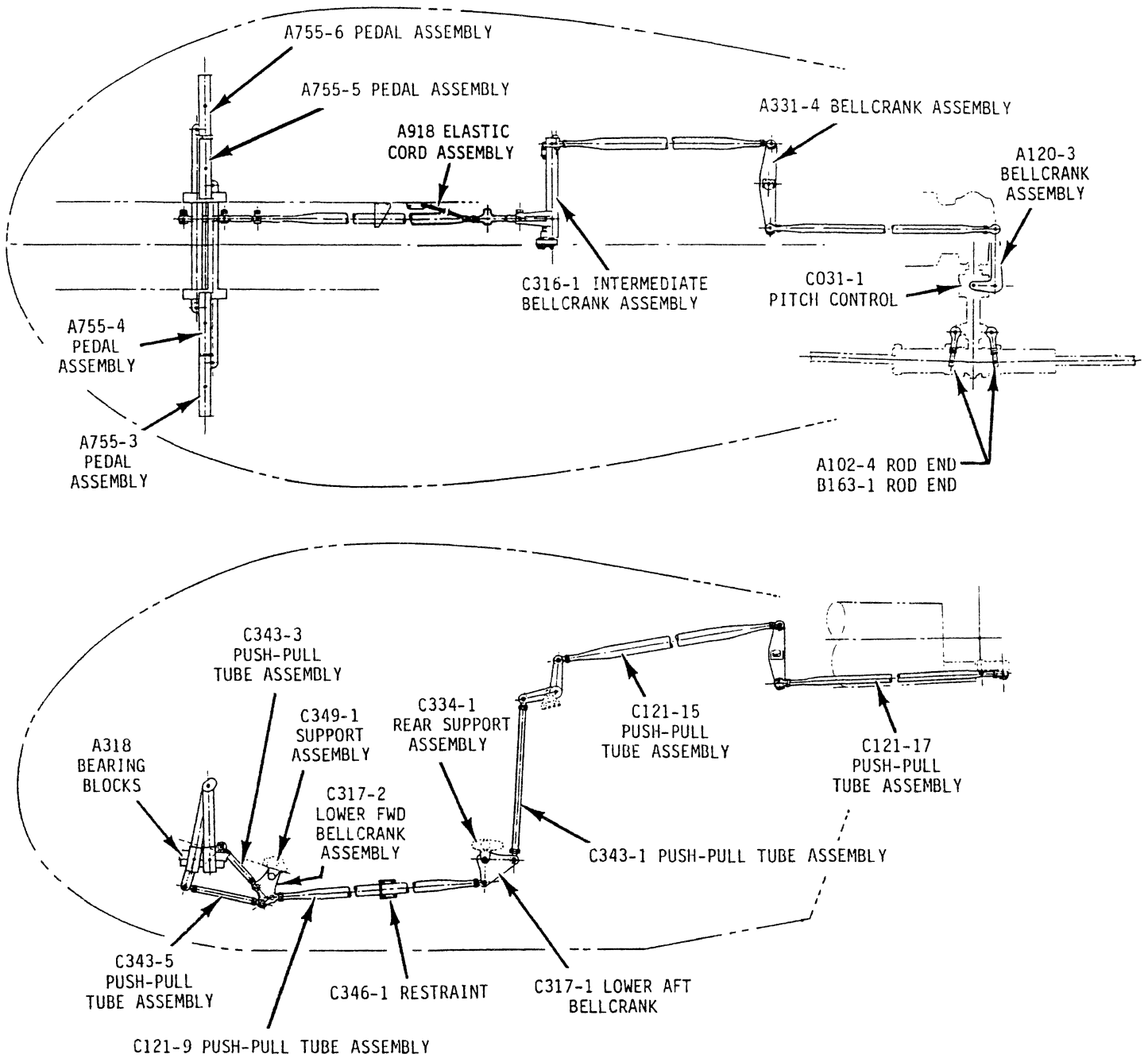

FIGURE 8-2 TAIL ROTOR FLIGHT CONTROLS

## 8.100 CYCLIC CONTROLS

### WARNING

Manual control (electric-trim) R44s require 0.065 inch wall thickness C319-3 torque tube assemblies with C177-2 pivot (C177-4 pivot assembly) and C176-3 yoke. R44s with hydraulic flight controls require 0.049 inch wall thickness C319-5 torque tube assemblies with C177-3 pivot and D696 yoke.

## 8.110 Cyclic Assembly

### 8.111 Cyclic Assembly Removal

- a) Remove belly panels and control tunnel covers.
- b) Remove roll pin from cyclic friction knob and remove knob. Install a pin on shaft to retain spacers. Remove carburetor heat control knob on ships equipped with carb heat assist.
- c) Remove C683-4 damper atop cyclic stick (not applicable to hydraulic flight controls).
- d) Remove all screws securing C444-1 cover. Disconnect post light wire and secure cover at highest point of cyclic stick.
- e) Open upper console and disconnect outside air temperature gauge and intercom system controller wiring. Remove radio face plate.
- f) Remove forward and aft longitudinal cyclic trim elastic cords per Section 8.131.

## 8.111 Cyclic Assembly Removal (cont'd)

- g) Install MT544-2 lateral trim spring assembly retainer onto lateral trim spring per Section 8.141. Remove B330-13 palnut and AN316-4R nut atop lateral trim spring shaft. It is not necessary to remove motor assembly from cyclic assembly.
- h) Disconnect electrical connections at bottom of cyclic stick.
- i) Remove NAS6604-8 bolt from forward end of C121-1 push-pull tube. Move push-pull tube aft and/or move cyclic grip aft to disconnect push-pull tube from cyclic stick.
- j) Remove two bolts connecting forward end of C319-3 torque tube assembly to C177-2 pivot and move torque tube assembly aft to disconnect it from pivot.

**CAUTION**

Protect C319-3 torque tube from scratches.

- k) Disconnect, but do not remove, two bolts holding cyclic friction assembly to cabin. Apply friction to help keep assembly together.
- l) Remove screws securing cyclic box to cabin. Lift cyclic assembly up and disconnect strain gage plug on left side of cyclic box, slide lateral trim assembly arm off spring assembly shaft, and remove cyclic stick assembly. Install nuts onto two friction assembly bolts, hand tight, to retain bolts and spacers.

**CAUTION**

Before removing cyclic, protect silicone-covered strain gages on cyclic stick with soft cloth or foam. Damaged strain gages or wiring will disable electronic trim system.

- m) Remove A231-9 hole plugs in keel panel in right aft baggage compartment. Remove NAS6605-46 bolt, C130-7 spacer and hardware connecting C121-7 push-pull tube lower rod ends to C176-2 yoke.
- n) Remove NAS6605-16 bolt and hardware connecting C121-3 push-pull tube lower rod end to C958-5 bellcrank.
- o) Disconnect A205-5 fork assembly from C326-7 bellcrank by removing NAS6604-38 bolt, C130-12 spacer, and related hardware.
- p) Remove C319-3 torque tube assembly and attached parts by moving assembly down and aft through belly.

## 8.112 Cyclic Assembly Installation

- a) Install C319-3 torque tube assembly (with attached C121-1 push-pull tube assembly, C176-2 yoke, C958-5 bellcranks, and A205-5 fork assembly) through aft belly of helicopter. Before installation, verify center-to-center distance between B115-1 bearings and A101-4 rod end in A205-5 fork is  $3.80 \pm 0.03$  inches and jam nut and palnut are torqued per Section 1.320.
- b) Connect A205-5 fork assembly to C326-7 bellcrank per Figure 8-3 and torque.
- c) Connect lower end of C121-3 push-pull tube to C958-5 bellcranks and torque.
- d) Connect C121-7 push-pull tubes to C176-2 yoke using a NAS6605-46 bolt and C130-7 spacer and torque. Install two A231-9 hole plugs in keel panel.
- e) Position cyclic stick between keel panels. Connect strain gage wire plug to cyclic box, carefully slide lateral trim assembly arm onto spring assembly shaft, and guide carb heat assist rod (if installed) thru box. Install all screws fastening cyclic box to cabin.

**CAUTION**

Exercise care when installing lateral trim assembly arm onto spring shaft to avoid damaging teflon liner in bearing bore.

- f) Connect C319-3 torque tube assembly to C177-2 pivot and torque.

**CAUTION**

Protect C319-3 torque tube from scratches.

- g) Fasten cyclic friction assembly to cabin.
- h) Connect forward end of C121-1 push-pull tube to cyclic stick and torque.
- i) Connect all electrical plugs at bottom of cyclic stick. Position protective sleeving to cover maximum amount of wiring possible and secure sleeving ends with lacing tape.
- j) Finger tighten AN316-4R nut on lateral trim spring shaft then install and torque B330-13 palnut. Remove MT544-2 retainer.
- k) Install longitudinal cyclic trim elastic cords per Section 8.132.
- l) Move cyclic control through all positions and verify that there are clearances and no binding. Turn master battery and trim switches on and check clearances with trim motor arms in different positions. Use circuit breakers to control position at which arms stop.

### 8.112 Cyclic Assembly Installation (cont'd)

- m) Install radio face plate, connect OAT gage and intercom system wires and ty-rap as required. Close and secure upper console.
- n) Connect cyclic box cover post light wire, guide carb heat assist actuating rod (if installed) thru hole in cover, and secure cover. Install cyclic friction knob, and roll pin. Install carburetor heat control knob on ships with carb heat assist.
- o) Install C683-4 damper assembly atop cyclic stick and torque per Section 1.330 (not applicable to hydraulic flight controls).
- p) Install all panels.
- q) Rig main rotor flight controls per Section 10.121 if any push-pull tube length was changed.
- r) Adjust trim controller per Section 14.710.

### 8.120 Cyclic Grip Assembly

#### 8.121 Cyclic Grip Assembly Removal

This may be accomplished without removal of complete cyclic assembly from rotorcraft.

- a) If installed, remove C683-4 damper and disconnect D140-1 trim controller from airframe wiring.
- b) Remove forward belly panel.
- c) Remove lacing tape from both ends of protective sleeving covering wires exiting base of stick assembly. Using pin extractor, remove from housing those pins connected to wires 234, 235, 236, 277, 280, 281, 611, 612, 613, 614, 615, and 939 (if installed). Attach a 3 foot length of safety wire or wire lacing tape to one removed pin.
- d) Remove cotter pin, castellated nut, and A141-14 washer where grip assembly attaches to stick assembly.
- e) Remove grommet atop cyclic stick at grip assembly wiring entrance. With a soft-faced hammer, gently tap cyclic grip assembly pivot and remove grip assembly and attached wiring from stick assembly. Ensure safety wire or lacing installed in step c) protrudes from top and bottom of stick assembly. Also, ensure pivot bearings remain with stick assembly.

#### NOTE

Do not damage bearings while removing.

This page intentionally left blank.

C334 AFT SUPPORT ASSEMBLY

<u>NUMBER</u>	<u>PART NUMBER</u>	<u>DESCRIPTION</u>	<u>NUMBER</u>	<u>PART NUMBER</u>	<u>DESCRIPTION</u>
1.	MS21042L3	Nut	27.	AN316-4R	Nut
2.	AN960-10L	Washer	28.	A127-4	Rod End
3.	D336-1	Plate	29.	NAS6604-8	Bolt
4.	C130-24	Spacer	30.	A141-3	Washer
5.	A130-21	Spacer	31.	A105-3	Journal
6.	C130-25	Spacer	32.	C317-1	Bellcrank Assy
7.	B1000-050-S	Spring Washer	33.	C121-9	Push-Pull Tube Assy (Ref)
8.	NAS6603-11	Bolt	34.	NAS6604-7	Bolt
9.	B249-6	Arm Assembly	35.	A205-5	Fork Assembly
10.	C315-7	Aft Support Assy Weldment	36.	C130-12	Spacer
11.	NAS6604-2	Bolt	37.	AN316-6R	Nut
12.	MS21042L4	Nut	38.	D173-1	Rod End
13.	AN960-416	Washer	39.	C121-19	Push-Pull Tube Assy (Ref)
14.	AN960-416L	Washer	40.	A130-47	Spacer
15.	B330-19	Palnut	41.	NAS6604-38	Bolt
16.	MS21042L6	Nut	42.	C326-7	Bellcrank
17.	AN960-616	Washer	43.	B303-1	Bearing
18.	B250-11	Journal	44.	C130-32	Spacer
19.	NAS6606-17	Bolt	45.	C958-5	Bellcrank
20.	B330-13	Palnut	46.	AN316-5R	Nut
21.	C038-5 or -6	Collective Spring Assy (Ref)	47.	B330-16	Palnut
22.	C311-1	Bolt	48.	A101-4	Rod End
23.	A141-11	Washer			
24.	NAS6604-11	Bolt			
25.	C343-1	Push-Pull Tube Assy (Ref)			
26.	B316-4	Rod End			

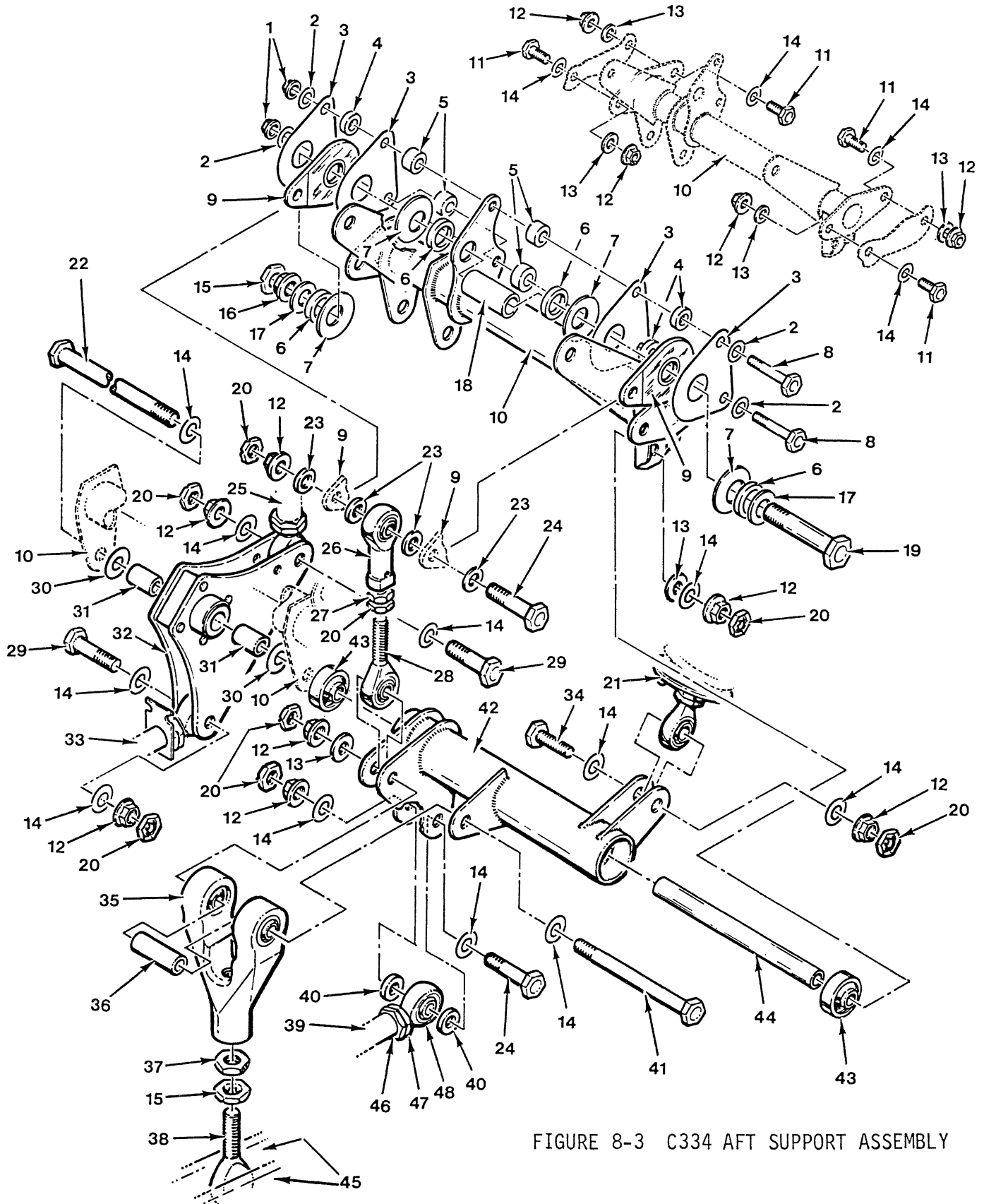

FIGURE 8-3 C334 AFT SUPPORT ASSEMBLY

**8.122 Cyclic Grip Assembly Installation**

- a) Ensure rollpin is installed in grip assembly with protruding end down. Protective sleeving covers wires exiting grip assembly with one grommet in grip and one on wire bundle.
- b) Slide grip assembly into bearings in stick assembly. Install A141-14 washer, castellated nut and cotter pin.

**CAUTION**

Tighten castellated nut only until there is no axial movement of bearings and cyclic grip assembly. Overtightening nut will damage bearings.

- c) Temporarily attach grip assembly wiring to safety wire (or lacing) exiting atop cyclic stick. Carefully pull wires thru cyclic stick. Install grommet, included with grip assembly wiring, into cyclic stick wiring entrance hole. Route grip assembly wires thru existing sleeving protecting wires exiting cyclic stick bottom. Remove safety wire (or lacing).
- d) Install pins on each wire into proper position in housings. Refer to Figures 14-2 and 14-4 for pin position.
- e) Position protective sleeving on wiring exiting cyclic stick bottom to cover maximum amount of wiring possible. Secure sleeving ends with lacing tape.
- f) Connect cyclic and airframe wiring and ty-rap. Move cyclic control through all positions and verify clearance and no binding. Turn master battery and trim switches on and check clearances with trim motor arms in different positions. Use circuit breakers to stop arms in different positions.
- g) Install end cap (hydraulic flight control) or C683-4 damper assembly (manual flight control) atop cyclic stick. Torque damper assembly attaching screws per Section 6.330.
- h) Install forward belly panel.
- i) Adjust trim controller per Section 14.710 (not applicable to hydraulic flight controls).

### 8.130 Longitudinal Cyclic Trim Elastic Cords

Elastic cords are used to zero longitudinal cyclic stick forces during hovering and cruise flight. Refer to Figures 8-4 and 8-4A.

One or two cyclic trim elastic cords are installed in the R44. One aft (cruise) cord, which imparts a forward cyclic force, is connected to the longitudinal trim motor cable. One optional forward (hover) elastic cord, which imparts an aft cyclic force, may be connected to the bottom of the cyclic stick assembly. Before replacing any elastic cord, ensure longitudinal trim motor arm is traveling thru its full operating range when cyclic stick is placed in full forward and then full aft position.

If cyclic grip moves forward in hover, a stronger forward elastic cord is required. If cyclic grip moves aft in cruise flight, a stronger aft elastic cord is required. Decreasing forward (hover) elastic cord strength by 5 pounds has the same effect as increasing aft (cruise) elastic cord strength by 10 pounds.

- a) Remove elastic cord per Section 8.131 and determine part number from identification tag.

#### NOTE

The R44 IPC lists elastic trim cords by part number and installed load (force).

- b) Using above information, and amount of force required to counter cyclic force, select an appropriate elastic trim cord from the IPC. If cord is old, try replacing it with same part number new cord first.
- c) Install per Section 8.132.
- d) Test fly helicopter to determine if proper cord was selected. The cyclic trim must zero (neutralize) cyclic forces during a 100 KIAS autorotation at C.G. station 99+.
- e) Repeat steps a) thru d) as required to balance longitudinal cyclic forces.

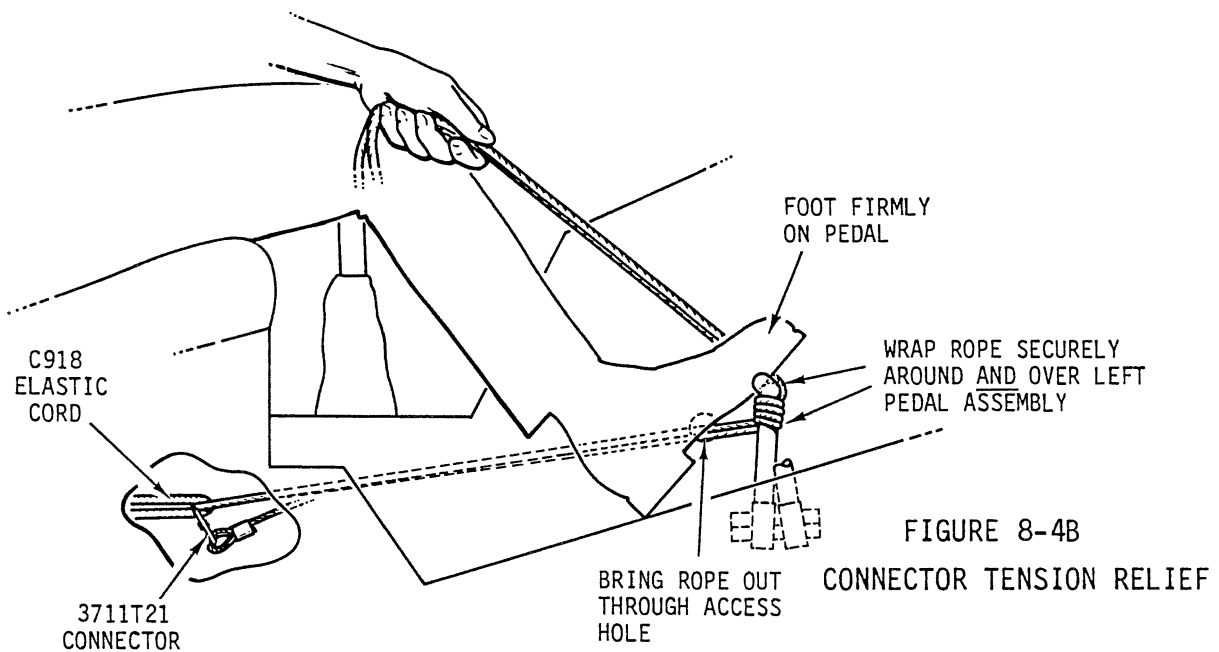
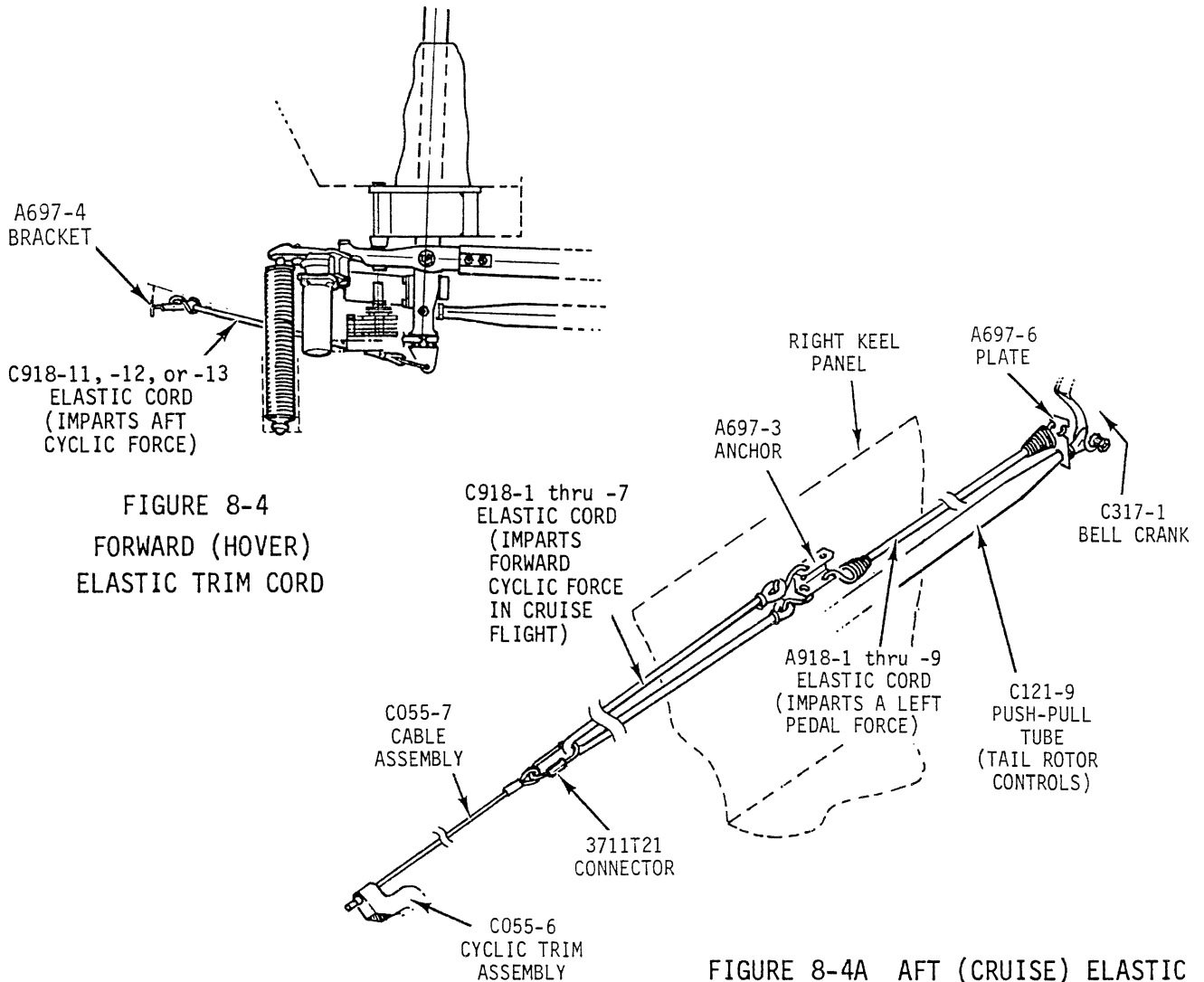

## 8.131 Elastic Cord Removal

**NOTE**

See Section 2 for elastic cord inspection criteria.

1. Aft elastic cord (C918-1 through -9):
  - a) Remove control tunnel covers (reference Figure 2-2, item 3A & 4F).
  - b) Turn master battery and trim switches on. Hold cyclic stick firmly against aft stop to allow longitudinal trim motor arm to go to upper stop. Turn master battery and trim switches off.
  - c) Move cyclic stick full forward. Remove black plastic hole plug from right keel panel just aft of right side tail rotor pedals.
  - d) Refer to Figure 8-4B. Apply full right pedal. Route one end of an 8 foot length of 1/4 inch diameter nylon rope through right keel panel hole just aft of right side tail rotor pedals, through C918 elastic cord next to 3711T21 connector and back through keel panel hole. Wrap both ends of rope around left pedal and hold securely. Slowly apply left pedal to take up slack on rope and relieve tension on 3711T21 connector. Unhook connector from C918 elastic cord. Let left pedal return slowly full aft.

**CAUTION**

Always remove tension on 3711T21 connector before unscrewing it. DO NOT allow C918 elastic cord to put tension on an unsecured 3711T21 connector.

- e) Very slowly, ease off tension on rope until there is no more tension on elastic cord.
  - f) Unhook both ends of elastic cord from A697-3 anchor riveted to right keel panel. Remove elastic cord.
2. Forward elastic cord (C918-11, -12, -13):
    - a) Remove forward belly panel.
    - b) Move the cyclic to full aft position.
    - c) Unhook the forward trim cord from the A697-5 clip located at the bottom of the cyclic stick.
    - d) Remove the trim cord hook from the forward bracket.

## 8.132 Elastic Cord Installation

## 1. Aft elastic cord installation

**CAUTION**

C918-8 and -9 elastic cords may only be used with C055-10 cyclic trim assembly.

- a) Hook both ends of trim cord to A697-3 anchor on right keel panel.
- b) Move cyclic to full forward position with longitudinal trim motor arm in up position.
- c) Refer to Figure 8-4B. Apply full right pedal. Route one end of an 8 foot length of 1/4 inch diameter nylon rope through right keel panel hole just aft of right seat tail rotor pedals, through C918 elastic cord next to 3711T21 connector, and back through keel panel hole. Wrap both ends of rope around left pedal and hold them securely.
- d) Reference Figure 8-4A. Slowly apply left pedal to stretch C918 elastic cord. Install and secure the 3711T21 connector between the C918 elastic cord and C055-7 cable assembly. Reference Figure 8-4A. Slowly release tension on rope. Remove rope.

**CAUTION**

DO NOT allow the C918 elastic cord to apply tension to an unsecured 3711T21 connector.

**WARNING**

Turn on trim system and ensure clearance is maintained between the elastic cord hooks, push-pull tubes and wiring throughout entire cyclic control and trim system travel.

- e) Reinstall all panels and the hole plug.
- f) Evaluate trim cord per Section 8.130(d).

**8.132 Elastic Cord Installation (cont'd)****2. Forward elastic cord installation**

- a) Hook forward end of elastic cord to bracket under radio rack.
- b) Pull cyclic to full aft position and hook aft end of trim cord to A697-5 clip located at bottom of cyclic stick.

**WARNING**

Turn on trim system and ensure clearance is maintained between elastic cord hooks, push-pull tubes, and wiring throughout entire cyclic control and trim system travel.

- c) Install belly panel.

**8.140 Lateral & Longitudinal Cyclic Trim Assemblies****8.141 Lateral Cyclic Trim Assembly Removal (C055-2 or C055-9)**

- a) Remove forward belly panel and panel between forward seats.
- b) Remove roll pin from cyclic friction knob and remove knob. Install pin on shaft to retain spacers. Remove carburetor heat control knob on ships equipped with carburetor heat assist.
- c) Remove all screws securing C444-1 cover. Disconnect post light wire and secure cover at highest point of cyclic stick.
- d) Open upper console and disconnect the OAT gage and intercom system wiring. Remove radio face plate.
- e) Turn master battery and trim switches on. Move and hold cyclic against right stop until lateral trim arm moves fully left. Then turn trim and master battery switches off and move cyclic stick to full left position to compress trim spring.
- f) Install MT544-2 lateral spring assembly retainer and secure with heavy-duty ty-raps at two places to spring assembly. Remove palnut and AN316-4R nut atop spring shaft.
- g) Disconnect lateral trim motor wiring.
- h) Remove two NAS6603-26 bolts which connect trim assembly to C177-2 pivot.
- i) Remove gearmotor assembly.
- j) If necessary, remove spring assembly by disconnecting C591-2 block from cabin assembly.

## 8.142 Lateral Cyclic Trim Assembly Installation (C055-2 or C055-9)

## CAUTION

There are two trim controller part numbers: D140-1 and D140-2. D140-1 trim controller must be used ONLY with C055-2, -6 and -8 cyclic trim assemblies. D140-2 trim controller must be used ONLY with C055-9, -10 and -11 cyclic trim assemblies. Incompatible controller and trim assembly(s) will result in trim system failure.

- a) If C056-1 spring assembly was removed, install C591-2 block (permanently attached to spring assembly bottom) in cabin. Orient attaching screw heads forward. Install trim assembly's two NAS6603-26 bolts downward thru C177-2 pivot. Carefully slide trim assembly arm onto spring shaft. Position trim assembly below, and attach it to, C177-2 pivot with NAS6603-26 bolts, two AN960-10L washers and two MS21042L08 nuts. Torque bolts per Section 1.320.
- b) Install AN316-4R nut finger tight on spring shaft, then install B330-13 palnut and torque palnut per Section 1.320. Move cyclic to left and remove MT544-2 lateral spring assembly retainer.
- c) Route trim motor wiring around front of and outboard of cyclic friction assembly. Connect trim motor wiring. Ty-rap wiring as required to prevent interference with flight controls.
- d) Turn master battery and trim switches on.
- e) Move cyclic to left stop and right stop and observe movement of trim motor arm throughout full range of travel. It must be free with no binding or interference. Turn master battery and trim switches off.
- f) Install radio face plate, connect OAT and intercom system wires, and ty-rap as required. Close and secure upper console.
- g) Connect cyclic box cover post light wire, guide carb heat assist actuating rod (if installed) thru hole in cover, and secure cover. Install cyclic friction knob and roll pin. Install carburetor heat control knob on ships with carb heat assist.
- h) Install all panels.
- i) Adjust trim controller per Section 14.710.

## 8.143 Longitudinal Cyclic Trim Assembly Removal (C055-6 or C055-10)

- a) Remove cyclic stick assembly per Section 8.111, steps a) thru k). Alternatively, perform steps a) thru e) and g) of Section 8.111 and leave cyclic stick assembly installed.
- b) Remove two NAS1352-08 screws connecting longitudinal cyclic trim assembly to cyclic stick. Remove trim assembly.

8.144 Longitudinal Cyclic Trim Assembly Installation (C055-6 or C055-10)

**CAUTION**

There are two trim controller part numbers: D140-1 and D140-2. D140-1 trim controller must be used ONLY with C055-2, -6 and -8 cyclic trim assemblies. D140-2 trim controller must be used ONLY with C055-9, -10 and -11 cyclic trim assemblies. Incompatible controller and trim assembly(s) will result in trim system failure.

- a) Refer to Figure 8-4C. Install trim motor assembly on cyclic stick with NAS1352-08-12P screw NAS620-8L washer and MS21042L08 nut in lower position and lightly tighten. Pivot motor upward and install NAS1352-08-32P screw, C130-11 spacer (may be secured to motor with ty-rap to ease installation), C130-20 spacer (chamfer pointing aft), NAS620-8L washer, and MS21042L08 nut in upper position. Remove ty-rap used to position C130-11 spacer, if installed. Torque nuts to 20-25 in.-lbs (includes nut self-locking torque).
- b) If removed, install cyclic stick assembly per Section 8.112 steps e) thru q). If cyclic was not removed, connect trim motor wiring and perform steps k) thru q) of Section 8.112.
- c) Adjust trim controller per Section 14.710.

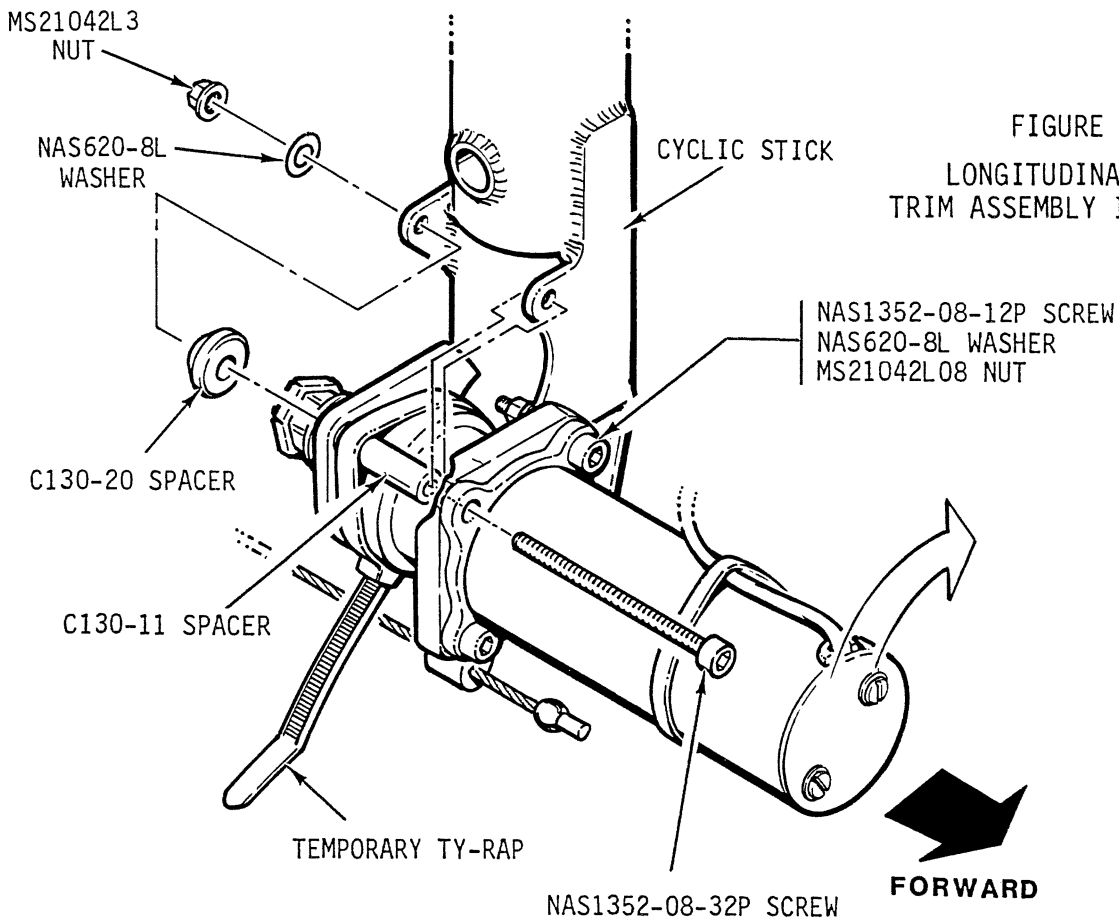

FIGURE 8-4C  
LONGITUDINAL CYCLIC  
TRIM ASSEMBLY INSTALLATION

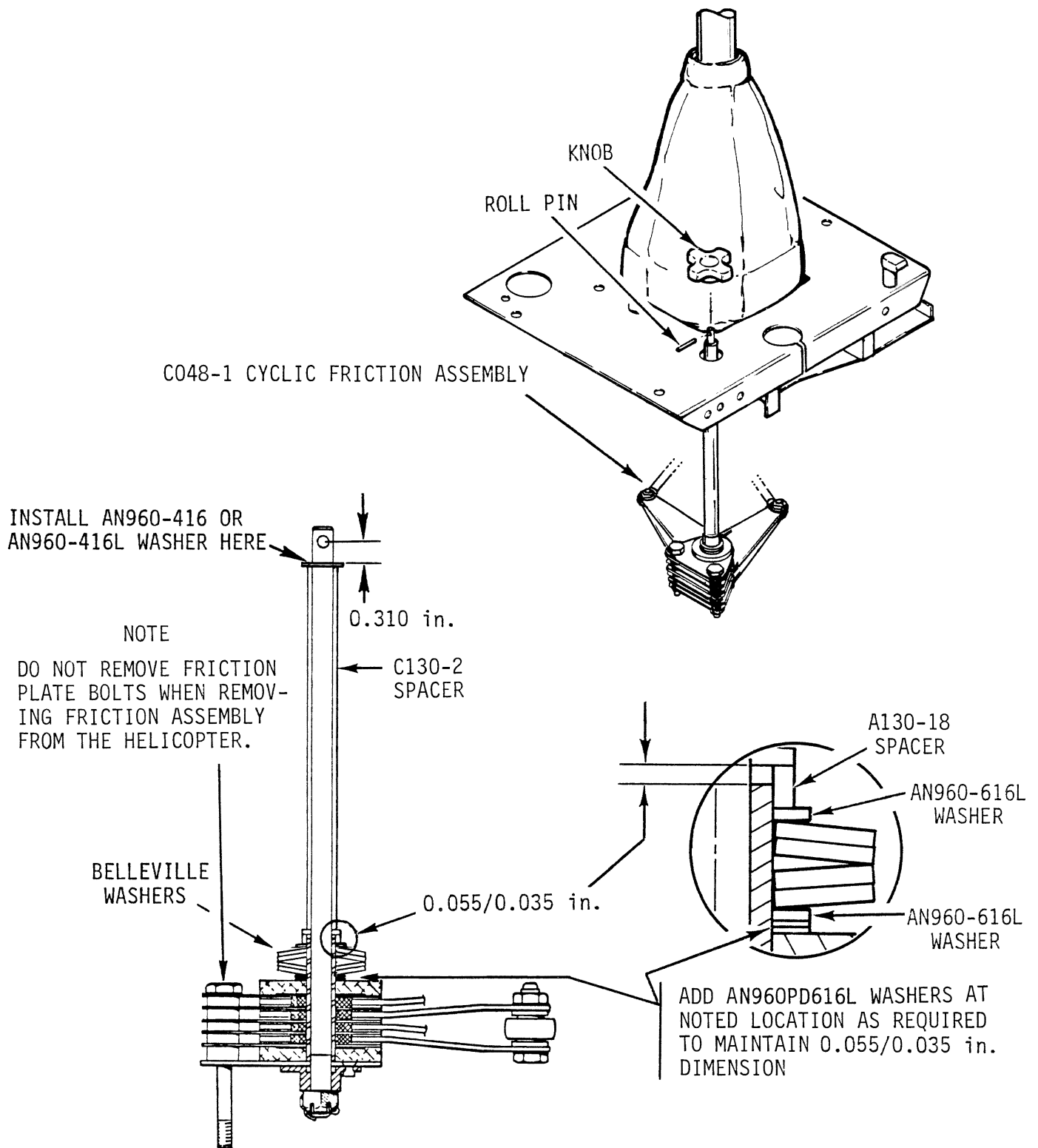

FIGURE 8-4D CYCLIC FRICTION ASSEMBLY AND ADJUSTMENT

### 8.150 Cyclic Friction Assembly

The cyclic friction assembly is located below the forward left corner of the cyclic box. Turning friction knob clockwise applies friction to both longitudinal and lateral cyclic axes. Adjustment is required if friction cannot be applied.

#### 8.151 Cyclic Friction Adjustment

- a) Turn friction knob counter-clockwise until it stops.
- b) Remove roll pin connecting knob to shaft.
- c) Lift knob off shaft.
- d) Install AN960-416 or -416L washer, as required, per Figure 8-4D so knob rotates 1/8 to 1 turn before adding friction. With friction on, force required to move cyclic in a lateral direction should be 7-13 lb (measured at grip) with trim motors in neutral position.
- e) Replace knob and install roll pin.
- f) Move flight controls throughout complete travel. Verify no binding or clearance problems exist.

### 8.160 C121-7 Push-Pull Tube

#### 8.161 C121-7 Push-Pull Tube Removal

- a) Remove aft belly panel.
- b) Remove mast fairing.
- c) Remove two plugs located in aft right baggage compartment.
- d) Remove NAS6605-46 bolt attaching C121-7 push-pull tube rod ends to C176-2 yoke.
- e) Disconnect bolts fastening C121-7 push-pull tubes to swashplate.
- f) Tape sheet metal edges to prevent push-pull tube damage.
- g) Position swashplate and rotor to slide C121-7 push-pull tube up and clear. Mark right and left tubes for reinstallation.
- h) Inspect push-pull tubes and sleeves for damage per Section 8.162.
- i) Inspect push-pull tube guide rollers for wear. Replace guide rollers if worn.

#### NOTE

If push-pull tube is replaced, adjust rod ends to obtain same center-to-center length or main rotor flight controls will require rigging per Section 10.

## 8.162 C121-7 Push-Pull Tube Inspection/Repair

- a) Nicks, cuts or scratches in tube which are longitudinal and no more than 0.010 inch deep, or across tube and no more than 0.005 inch deep, may be polished out.
- b) Tubes dented or flattened more than five percent of diameter must be replaced.
- c) Maximum tube wear at guide is 0.015 inch per wall after polishing wear ridges. Epoxy prime repair surfaces before sleeve installation. Any tube wear requires new sleeve installation.
- d) Replace tube worn in excess of 0.015 inch after polishing.

## 8.163 C121-7 Push-Pull Tube Sleeve Installation

## NOTE

Repair any wear damage on C121-7 push-pull tube per Section 8.162 prior to the push-pull tube sleeve installation.

- a) Clean push-pull tube with MEK or acetone.
- b) Apply tape to restrict adhesive to a six-inch long area beginning 30.5 inches from lower end of push-pull tube (not end of rod end).
- c) Test paint for paint bubbling; apply 1-inch band of B270-3 adhesive to one end of six inch area. If paint bubbles, remove paint and apply epoxy primer to area before applying adhesive.

## WARNING

Adhesive to be applied to complete area under push-pull tube sleeve.

- d) Apply adhesive supplied in kit to entire six-inch long area. (Adhesive will quickly set and become stringy. Brush on thin coat of adhesive without large lumps as rapidly as possible).

## NOTE

Sleeve must be installed within two minutes after adhesive is applied.

- e) Slide sleeves onto tube and center on adhesive.
- f) Rotate tube and apply heat using up to 1200-watt heat gun to evenly shrink sleeve and produce a smooth surface.

## CAUTION

DO NOT apply heat continuously to same area.

**8.163 C121-7 Push-Pull Tube Sleeve Installation (cont'd)**

- g) Allow to cool and apply adhesive to seal end of sleeve. Do not allow adhesive at sleeve ends above surface of sleeve or sleeve will be damaged or will not enter guide during installation.

**8.164 C121-7 Push-Pull Tube Sleeve Inspection**

Visually inspect sleeve for wrinkles, pin holes, bubbles, gouges, torn areas, etc. Replace sleeve if any damaged or suspect areas are found.

**8.165 C121-7 Push-Pull Tube Installation****CAUTION**

Exercise extreme care when installing C121-7 push-pull tube into guide to prevent damage to push-pull tube sleeve.

- a) Install C121-7 push-pull tube and hardware per Figure 8.4F.
- b) Attach C121-7 push-pull tubes to swashplate.
- c) Reinstall mast fairing. See Figure 8-4E.

**NOTE**

Locate and tighten clamp holding lower fairing rib to mast tube assembly prior to closing.

- d) Remove protective tape from sheet metal edges used to protect push-pull tubes during installation and close mast fairing.
- e) Check full travel clearances of flight controls.
- f) Verify fasteners are torqued.
- g) Install panels and baggage compartment plugs.
- h) If push-pull tube rod end center-to-center dimension was changed, check main rotor rigging per Section 10.

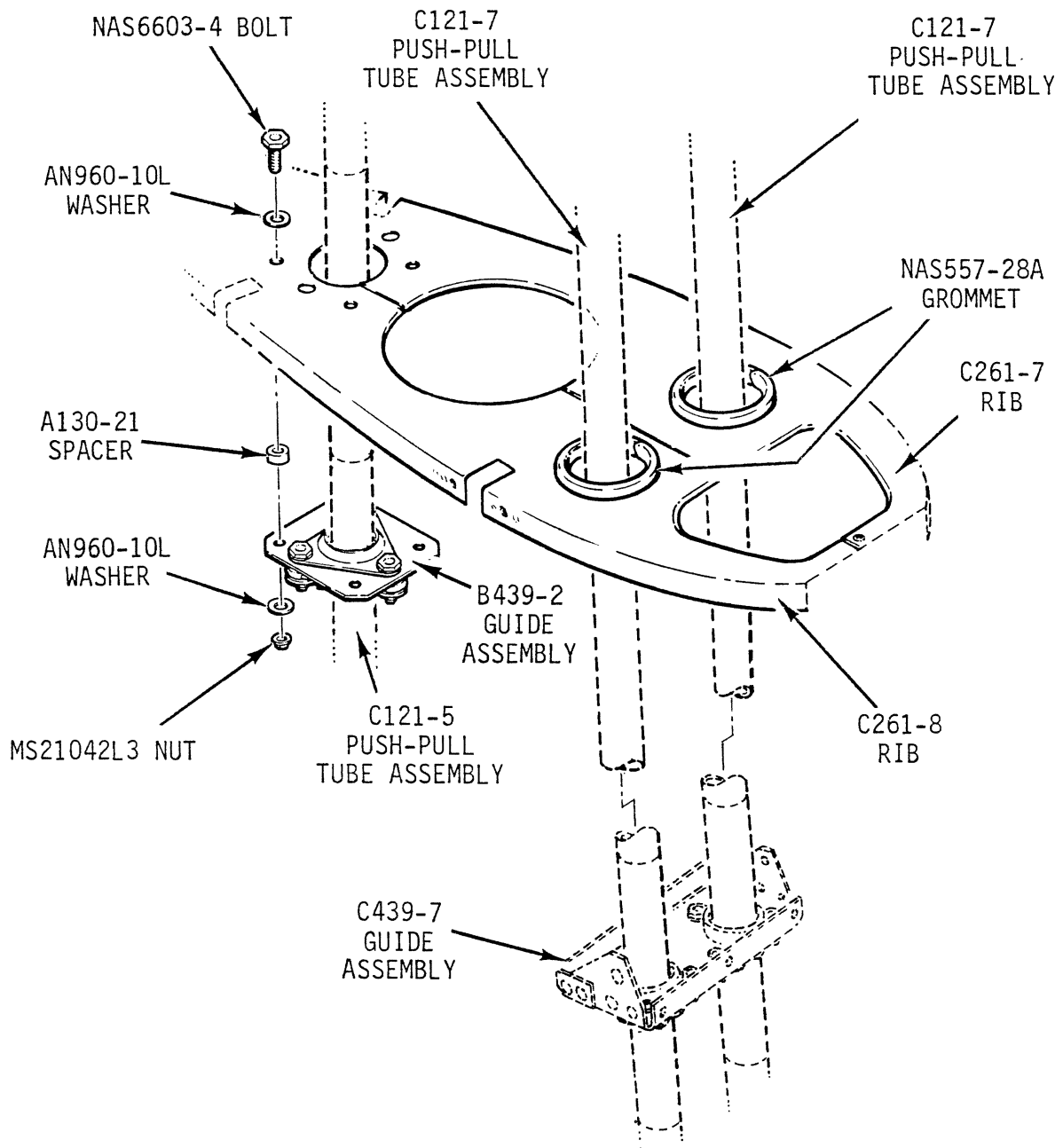

FIGURE 8-4E PUSH-PULL TUBES AND GUIDES  
(Electric Trim System only)

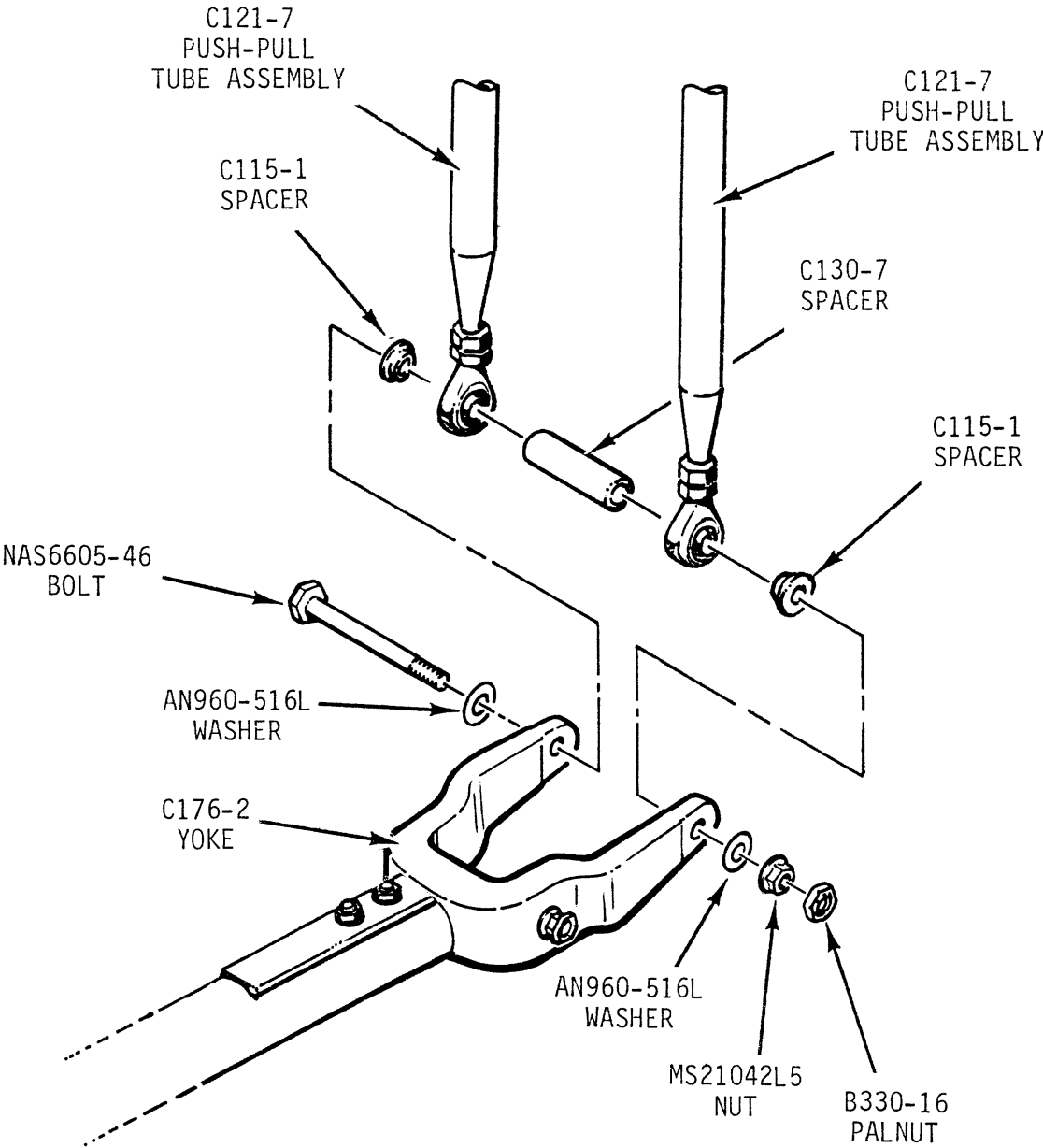

FIGURE 8-4E C121-7 PUSH-PULL TUBE ASSEMBLY INSTALLATION

**8.200 COLLECTIVE CONTROL****8.210 Collective Stick Assembly****8.211 Collective Stick Removal**

- a) Remove forward horizontal panel, aft vertical panel, both collective boot covers, and the collective cover located behind forward left seat back.
- b) Install the MT544-1 spring retainer on the collective spring located at the vertical tunnel while collective is in full down position.
- c) Disconnect forward end of C121-19 Push-Pull tube from the collective by removing NAS6604-9 bolt.
- d) Unplug the governor motor wiring located near left side of collective stick.
- e) Disconnect collective stop from the anchor by removing the NAS6603-5 bolt and disconnecting the overtravel spring from the collective.
- f) Remove one NAS6604-17 bolt which connects the collective assembly to the fuselage located behind the pilot's seat on the right keel panel.
- g) Remove the three screws holding the C303-1 support at the left end of the collective. The support is to be removed with the collective assembly.
- h) Remove collective.

**8.212 Collective Stick Installation**

- a) Assemble A332-1 friction lever per Figure 8-5. The spring washers, item 14, should be assembled with their concave sides together. The two washers, item 13, are installed with the grey Teflon<sup>®</sup> coated surface against the A333-1 stop (item 12). The A332-1 lever is threaded onto the NAS1352-4-24P screw as the screw starts to protrude from the attachment fitting.

**NOTE**

See collective friction adjustment for finalizing friction assembly after completion of collective installation. Refer to Section 8.224.

- b) Connect C303-1 support to collective stick, if required. Install NAS6604-11 bolt and attaching hardware. Torque per Section 1.320.
- c) Install collective stick into rotorcraft.
- d) Connect collective inboard attach bolts. Torque to per Section 1.320.

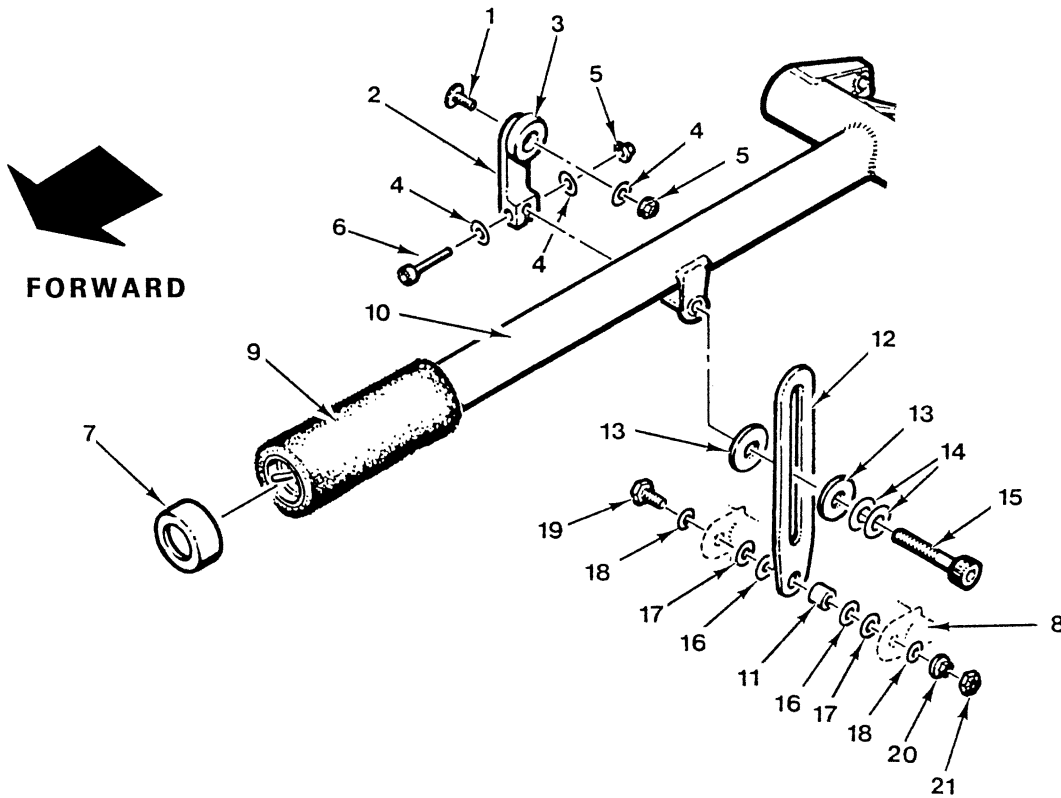

FIGURE 8-5 COLLECTIVE FRICTION ASSEMBLY

<u>NUMBER</u>	<u>PART NUMBER</u>	<u>DESCRIPTION</u>	<u>NUMBER</u>	<u>PART NUMBER</u>	<u>DESCRIPTION</u>
1	MS27039C0806	Screw	13	A141-20	Washer
2	A332-1	Lever	14	B0500-022-S	Belleville Washer
3	A431-1	Knob	15	NAS1352-4-24P	Screw
4	AN960-8L	Washer	16	AN960-416	Washer (A/R)
5	MS21042L08	Nut	17	AN960-416L	Washer (A/R)
6	NAS1352-08-12P	Screw	18	AN960-10L	Washer
7	A959-2	End Cap	19	NAS6603-5	Bolt
8	C348-1	Anchor	20	MS21042L3	Nut
9	A601-1	Grip	21	B330-7	Palnut
10	C758	Collective Assy			
11	A130-4	Spacer			
12	A333-1	Stop			

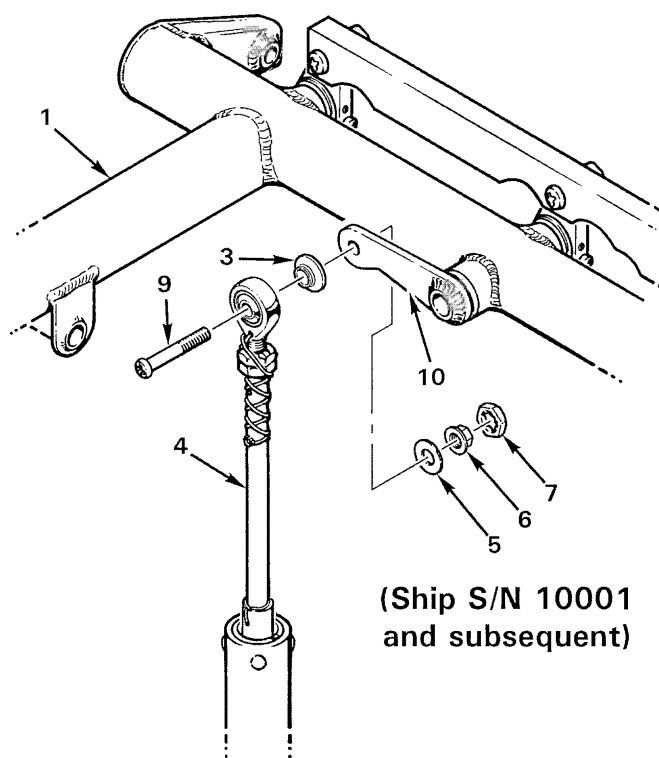
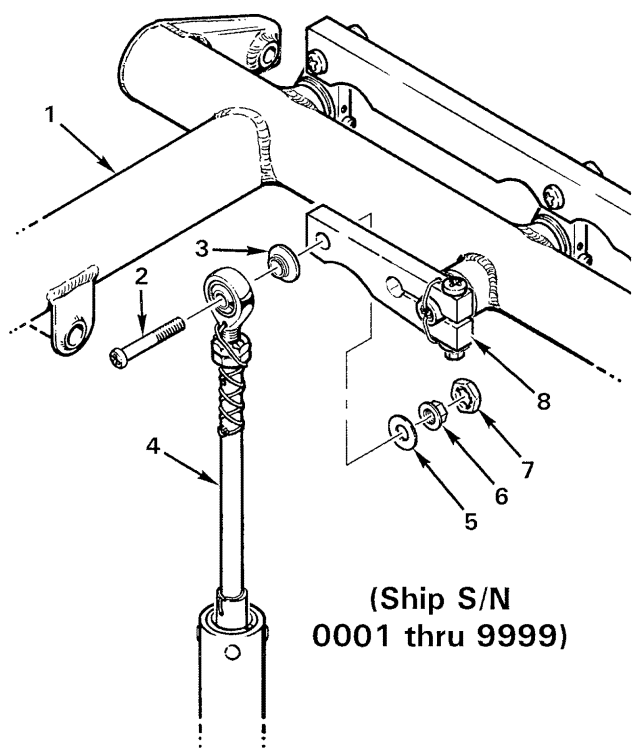

FIGURE 8-6 UPPER OVERTRAVEL SPRING INSTALLATION

NUMBER	PART NUMBER	DESCRIPTION
1	C758	Collective Assembly
2	A486-1	Screw
3	A341-1	Spacer
4	A327-1	Overtravel Spring Assembly
5	NAS1149F0332P	Washer
6	MS21042L3	Nut
7	B330-7	Palnut
8	C342-1	Arm Assembly
9	A486-4	Screw
10	C341-1	Arm Weldment

## 8.212 Collective Stick Installation (cont'd)

- e) Connect left support held in place by one upper MS37039C1-08 screw, AN960-10L washer and MS21042L3 nut. Install two lower MS27039C0806 screws, AN960-8L washers and MS21042L08 nuts.
- f) Install lower end of A333-1 stop to the C348-1 anchor. When installing A333-1 stop onto the A130-4 spacer, add AN960-416 and 416L washers on either side of stop as required to align stop with collective and to obtain 0.001 to 0.035 inch axial play. Torque nut per Section 1.320. Install palnut and check for binding and axial play.
- g) Connect C121-19 Push-Pull tube to collective. Torque NAS6604-9 bolt per Section 1.320.

**CAUTION**

The NAS6604-9 bolt at the forward end of the C121-19 push-pull tube must be installed so the bolt head is toward the left side of the helicopter. Refer to Figure 8-1.

- h) Connect governor motor plug to the connector.
- i) Remove the MT544-1 spring retainer from the collective spring assembly.
- j) Install the A327-1 overtravel spring to the collective arm (see Figure 8-6).

**NOTE**

Use special A486 screw and A341-1 spacer. With screw head against rod end ball, install spacer with large diameter against collective arm. Torque to 28 in.-lb plus nut drag and install palnut.

**WARNING**

Improper installation can cause binding, rod end damage or rod end separation with subsequent loss of engine throttle control.

- k) For rigging of throttle correlation, see Section 10.150.
- l) Verify all bolts and fasteners torqued.
- m) Install all panels.

## 8.213 Pilot-Adjustable Collective Friction (see Figure 8-5)

1. Loosen screw (6) on friction lever.
2. a. Manual controls - Hold friction lever knob 0.3-0.6 inch aft of full-forward position. Adjust screw (15) until washers (13) cannot be rotated with fingers then tighten friction lever screw (6).
- b. Hydraulic flight controls - Hold friction lever knob fully aft against collective stick. Adjust screw (15) to produce a force of 18-22 pounds at collective grip, then tighten friction lever screw (6).

## 8.214 Fixed Collective Friction Adjustment (manual controls only, see Figure 8-3)

1. Remove vertical center panel between aft seatbacks.
  2. a. Manual controls - see Figure 8-3. Tighten bolt (19) as required to eliminate feedback load through collective without being excessive.
  - b. Hydraulic flight controls - With carburetor heat LOCKED and pilot-adjustable collective friction fully off (zero friction), adjust NAS6606 bolt as required to produce 4-5 pounds (average of both directions) force at collective grip within servo deadbands.
3. Adjust pilot-adjustable collective friction per Section 8.213.

8.220 Collective Spring Assembly (manual controls only, see Figure 8-8)

The collective spring assembly is installed to balance the collective control forces produced in flight by the main rotor. The spring in the C038-5 or C038-6 spring assembly may be changed or adjusted to balance the collective control after main rotor blade change.

**WARNING**

When collective spring is compressed and retaining rings are installed, extreme care must be taken not to remove retaining rings unless suitable safety device is used to slowly relieve tension (see Figure 8-8).

## 8.221 Collective Spring Removal &amp; Servicing

1. Remove aft vertical center panel between aft seat backs.
2. Place the collective in the full down position. Install 3 MS16633-2018 retaining rings in grooves on guide rods. If necessary, loosen locking nuts and rotate spring until grooves in guide rods are exposed. Carefully raise collective until retaining rings contact cap.

**WARNING**

Spring is under compression.

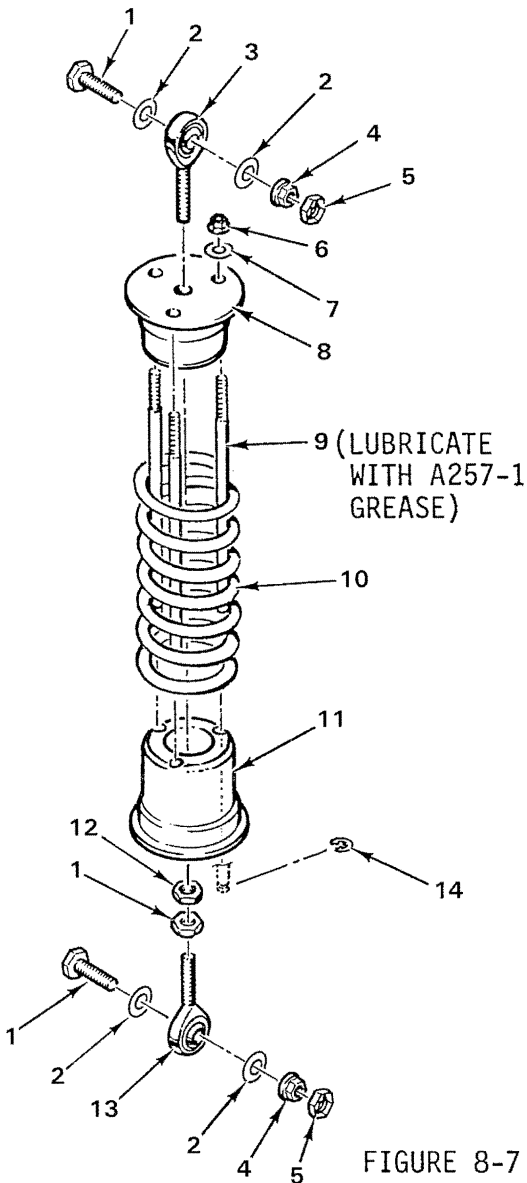

FIGURE 8-7 C038-5 AND -6 COLLECTIVE SPRING ASSEMBLY

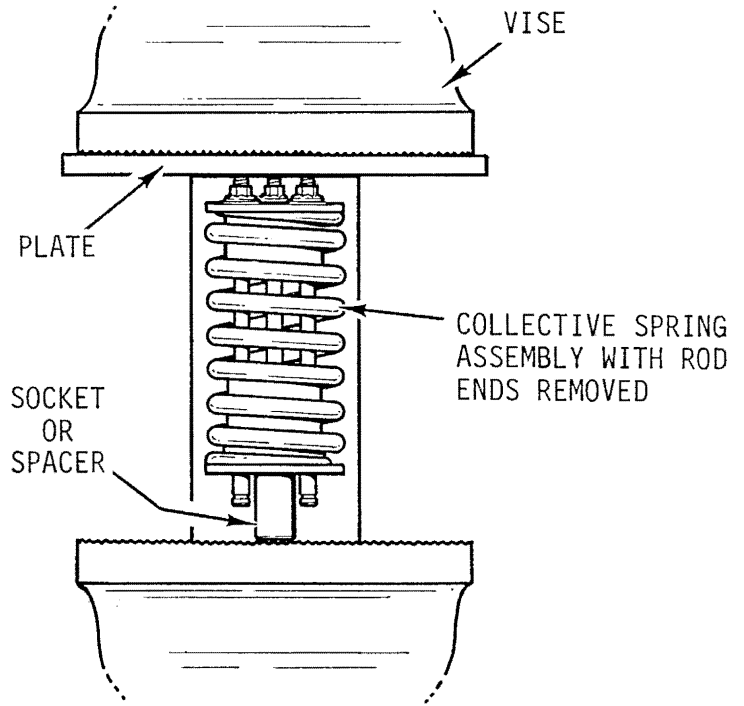

FIGURE 8-8  
SUGGESTED METHOD  
FOR RELIEVING  
SPRING COMPRESSION

NUMBER	PART NUMBER	DESCRIPTION	NUMBER	PART NUMBER	DESCRIPTION
1	NAS6604-7	Bolt	10	A429-11	Spring (Strong; for C038-5 Assy)
2	AN960-416L	Washer		A429-12	Spring (Medium; for C038-6 Assy)
3	B292-4	Rod End (left-hand thread)		A429-13	Spring (Weak; for C038-7 Assy)
4	MS21042L4	Nut	11	C426-2	Cap
5	B330-13	Palnut	12	AN316-4R	Nut
6	MS21042L3	Nut	13	A127-4	Rod End
7	AN960-PD10L	Washer	14	MS16633-3018 (or -2018 or -1018)	Retaining Ring (used for removal and installation only)
8	C426-1	Cap			
9	C428-2	Rod			

## 8.221 Collective Spring Removal &amp; Servicing (cont'd)

3. Remove bottom spring attach bolt.
4. Disconnect spring assembly upper attach bolt and remove spring assembly.
5. Remove rod ends from spring assembly and inspect. Verify threaded shanks are straight and play is with Section 2.120 limits.
6. Install spring assembly in vise per Figure 8-8. Remove retaining rings and decompress spring.
7. Clean C426-2 lower cap and inspect 0.194 inch diameter guide rod holes. Replace cap if holes are elongated, tapered, or greater than 0.204 inch diameter (a suitable size drill bit shank may be used as a go/no-go gauge).
8. Clean guide rods and inspect visible portions. Guide rods must be straight, cylindrical, and smooth. Replace guide rods if bent, tapered, worn or rough.
9. Lubricate guide rods with A257-1 grease (ref. Section 1.470) and reassemble spring assembly in reverse order.

## 8.222 Collective Spring Installation

**WARNING**

Install with nut end of guide rods pointing up (see Figure 8-7).

**WARNING**

When installing the C038 spring assembly, both rod ends must extend an equal number of turns (B292-4 rod end has left-hand thread). Failure to ensure both rod ends protrude equally can cause either one to run out of threads during adjustments and can cause bodily harm.

1. Connect B292-4 upper rod end to C427 support assembly and torque NAS6604 bolt per Section 1.320.
2. Move collective to align rod end into C326 bellcrank. Install bolt and torque per Section 1.320.
3. After installation of spring assembly, remove all three retaining rings from guide rods.

### 8.222 Collective Spring Installation (cont'd)

4. Verify coils are not binding with collective stick full down. Adjust spring assembly as required per § 8.223.

**WARNING**

**Failure to remove retaining rings or allowing spring coils to bind can limit control travel.**

5. Operate collective through its full range of travel and check for any interference or binding.
6. Install removed panels.

### 8.223 Collective Spring Adjustment

Small force adjustments may be made by extending or contracting overall length.

1. Secure collective fully down.
2. Remove panel between aft seatbacks.
3. Loosen palnut and jam nut on A127-4 rod end at bottom of spring assembly.
4. Rotate spring assembly to increase or decrease collective-up force (lower rod end is right-hand thread and upper rod end is left-hand thread). Extending rod ends increases collective-up force; screwing rod ends in decreases collective-up force.
5. Standard torque jam nut per § 23-32.

**WARNING**

**Ensure spring coils do not touch with collective full down after making adjustment. Spring coils that touch can limit flight control travel.**

6. While observing collective spring, move collective fully up and down and verify no interference.
7. Install removed panels.

### 8.230 RPM Governor System

The governor maintains engine RPM by sensing changes and applying corrective throttle inputs through a friction clutch which can be easily overridden by the pilot. The governor is active only above 80% engine RPM and can be switched on or off using the toggle switch on the end of the right seat collective.

The governor is designed to assist in controlling RPM under normal conditions. It may not prevent over- or under-speed conditions generated by aggressive flight maneuvers.

**CAUTION**

When operating at high density altitudes, governor response rate may be too slow to prevent overspeed during gusts, pull-ups, or when lowering collective.

### 8.231 Governor Controller Removal

**WARNING**

**No external adjustment of controller is available. If controller fails to operate correctly, remove and return it to RHC.**

1. Remove left hand, aft backrest.
2. Turn battery switch off & pull out GOV (2 amp) circuit breaker on circuit breaker panel.
  - a. D270-1 Governor controller: Loosen screws and disconnect airframe harness connector from governor controller; disconnect 1598-01C cable from governor controller. Cut and discard ty-raps as required and disconnect MAP line from governor controller.
  - b. D278 Governor controller: Disconnect airframe harness connector from D278 governor controller.
3. Remove hardware securing governor controller to C679-3 (LH) cover and remove governor controller.
4. Remove 40-4-2-N-0 elbow from D270-1 governor controller, as required.

### 8.232 Governor Controller Installation

#### CAUTION

Earlier R44-series helicopters that are not equipped with D270-1 governor controller / engine monitoring unit use a D278 governor controller. R44 helicopters require the D278-1 controller; R44 II helicopters require the D278-2 controller.

1. Turn battery switch off & pull out GOV (2 amp) circuit breaker on circuit breaker panel.
2. If D270-1 governor controller does not have 40-4-2-N-0 elbow installed, apply light coat B270-6 sealant to elbow threads (do not apply sealant to first thread) and install in governor controller finger tight. Continue tightening elbow to orient elbow perpendicular to governor controller data plate.
3. Install hardware securing D270-1 or D278 governor controller to C679-3 (LH) cover. Verify security.
4.
  - a. D270-1 Governor controller: Connect airframe harness connector to governor controller and tighten screws; connect 1598-01C cable to governor controller. Connect MAP line to governor controller and install ty-raps. Cinch ty-raps until snug without over-tightening and trim tips flush with heads.
  - b. D278 Governor controller: Connect airframe harness connector to D278 governor controller.
5. Push in GOV (2 amp) circuit breaker on circuit breaker panel.
6. Install left hand, aft backrest.

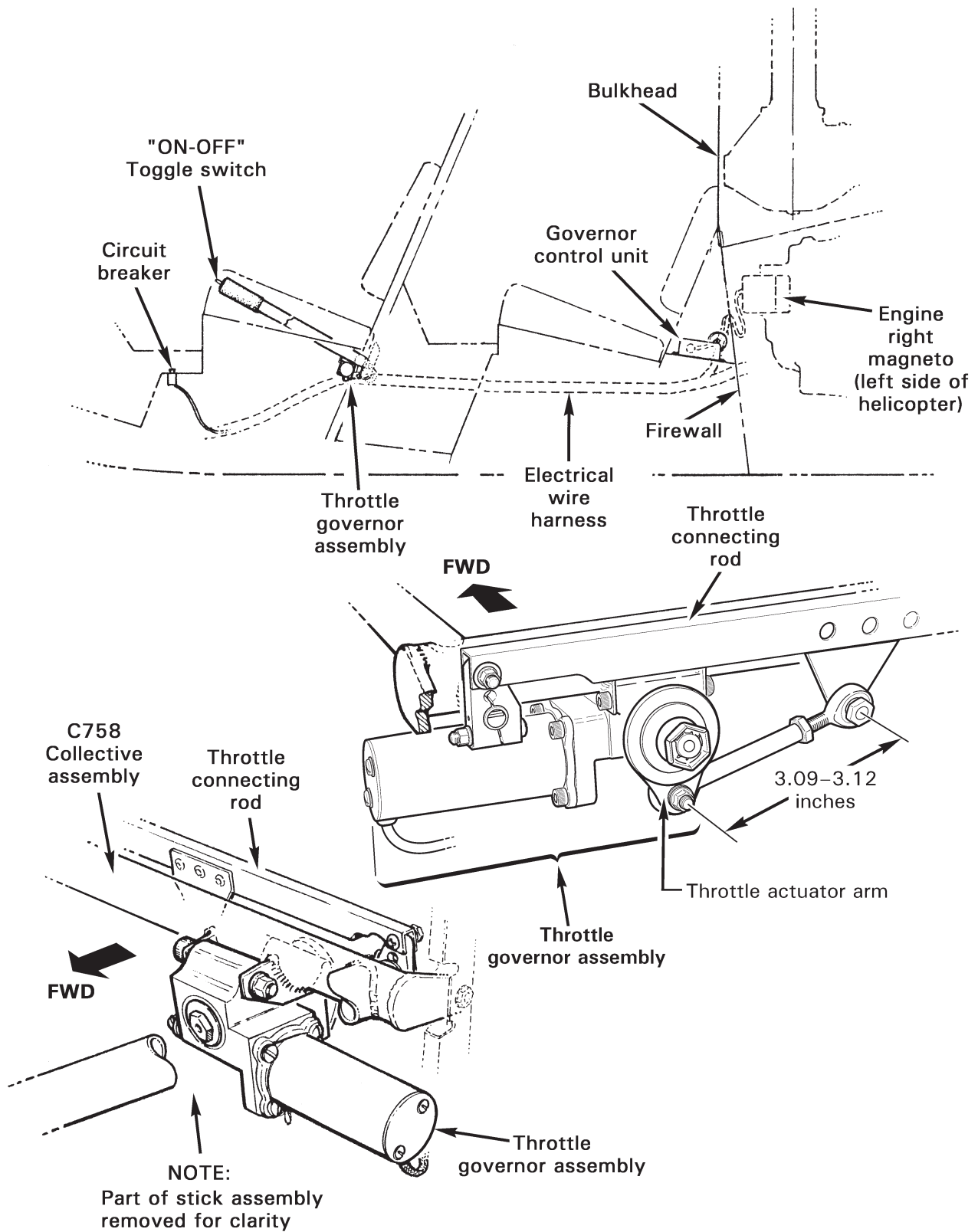

FIGURE 8-8A THROTTLE GOVERNOR INSTALLATION

### 8.233 Governor Assembly Removal

The governor assembly is attached to the collective stick behind the left forward seat.

#### WARNING

**No adjustment of the friction clutch is permitted. No replacement of the gear motor is permitted. If the friction setting is incorrect, or the gear motor operates incorrectly, remove the complete assembly and return to RHC.**

- a) Remove collective stick assembly per § 8.211.
- b) Remove the NAS6603-6 bolt from the connecting rod.
- c) Remove on NAS1351-4-28P screw and NAS1291-4 nut.
- d) Cut safety wire and remove two AN503-8-4 screws.
- e) Remove B247-5 governor assembly.

### 8.234 Governor Assembly Installation

- a) Connect the connecting arm to the governor assembly.

#### NOTE

DO NOT change the length on the connecting rod. The rod ends center-to-center distance should be 3.09–3.12 inches.

- b) Install two AN960-10L washers, one between rod end and governor motor arm and one under the nut. Torque nut and palnut per § 23-32.
- c) Install the NAS1351-4-28P screw and torque per § 23-32.
- d) Install the two AN503-8-4 screws and torque to 27 in.-lb and safety wire with 0.020 inch diameter safety wire.
- e) Install collective stick per § 8.212.

## 8.239 Governor Troubleshooting

### A. D278-1 & D278-2 Governor Controllers

The majority of governor problems are caused by the engine-right (helicopter left side) magneto's tachometer contact assembly (points) being out of adjustment or faulty. Refer to TCM Master Service Manual for tachometer contact assembly installation and adjustment.

#### NOTE

When checking contact assembly gap, always check gap twice (i.e. with cam follower resting at each cam lobe apex). If allowable gap tolerance cannot be maintained at each cam lobe apex, submit magneto to an authorized repair facility.

When switched on, the governor is active from 80% to 112% engine rpm. Below 80% and above 112% engine rpm the governor will take no action.

When operating in the active range, the governor will attempt to maintain engine rpm at approximately 102%  $\pm$  0.5% (D278-1 controller) or  $\pm$  0.75% (D278-2 controller). The edges of this governed rpm window – called a “deadband” – may be detected when the helicopter is in stable (no gusts), straight and level flight as follows:

1. Gently hold throttle and very slowly increase rpm (do not exceed 104%). Note and record engine rpm indication when governor input (subtle throttle resistance) is encountered.
2. Gently hold throttle and very slowly decrease rpm (do not go below 99%). Note and record engine rpm indication when governor input (subtle throttle resistance) is encountered.
3. Subtract second reading from first reading. Result should be approximately 1% (D278-1) or 1½% (D278-2).

A deadband not centered on 102% is indicative of a governor controller problem.

A wider-than-normal deadband, but still centered on 102%, is usually indicative of excessive throttle linkage friction and/or insufficient governor friction.

Check throttle friction by disconnecting overtravel spring assembly upper rod end from C341/C342 arm and attaching a spring scale to the rod end. With throttle arm in idle position, slowly pull up overtravel spring assy with spring scale and note maximum 4 pounds moving friction prior to full open throttle. Excessive throttle linkage friction can be caused by binding rod ends, control interference, carburetor throttle shaft bushing elongation, or binding carburetor accelerator pump (typically binds in one direction only).

### 8.239 Governor Troubleshooting (continued)

#### **A. D278-1 & D278-2 Governor Controllers (continued)**

Check governor friction with collective down, collective friction on, overtravel spring assy upper rod end disconnected from C341/C342 arm, and arm positioned horizontally. Attach a spring scale to hole in the arm and, with scale held tangential to arm, slowly pull on scale and note both the breakaway and the moving frictions. Breakaway friction is typically 0–0.5 pound greater than moving friction. Breakaway friction 1 pound or greater than moving friction may indicate damaged or contaminated governor friction clutch. Moving friction must be minimum 8 pounds until arm stops moving. Insufficient moving friction can be caused by wear, contamination, or loss of spring rate.

Proper governor operation requires a minimum 2:1 ratio of governor friction-to-throttle linkage friction.

Erratic operation is usually indicative of wiring damage or tachometer point problems. Wiring damage may be evidenced by crushing, pinching, or abrasion, all of which can result in grounding of one or both center wire conductor(s) to the shielding or to structure. Tachometer point problems may be caused by contamination (due to over-lubrication of magneto cam follower felt), oxidation (such as from an obstructed vent plug or leaking magneto drive seal), or loose contact(s), in addition to installation or assembly errors.

When flying in turbulence, or if the engine is lightly “loaded” (drive train almost freewheeling) a fluctuating MAP indication is expected.

Any loose connection in throttle linkage (including worn carburetor throttle shaft bushings) will result in both RPM & MAP oscillations.

### 8.300 Jackshaft and Support Struts

#### 8.310 Jackshaft (See Figure 8-9)

##### 8.311 Jackshaft Removal

**NOTE**

Rigging check is not necessary if jackshaft support strut rod ends and push-pull tube rod ends are not moved.

- a) Disconnect the push-pull tubes from the jackshaft.
- b) Disconnect the two jackshaft support bolts at the upper support rod ends.
- c) Remove jackshaft.

##### 8.312 Jackshaft Installation

- a) Install jackshaft to strut rod ends. Aft support rod end requires a C141-1 safety washer between the rod end ball and bolthead.
- b) Torque nuts per § 23-32 and install palnut.
- c) Connect the C121-3 and -5 push-pull tubes to jackshaft. Both push-pull tube attach boltheads point forward. The forward C121-3 push-pull tube rod end requires a C141-1 safety washer and C115-1 spacer between the rod end and bolthead. The aft C121-5 push-pull tube rod end requires a C141-1 safety washer between the rod end and bolthead.
- d) Torque nuts per § 23-32 and install palnut.
- e) Verify no binding or interference with control system exists throughout flight control travel.

### 8.320 Strut Assembly (Jackshaft Support)

#### 8.321 Jackshaft Strut Removal

- a) Remove jackshaft per § 8.311.
- b) Remove the support struts from the main rotor gearbox fittings. Disconnect the aft vertical strut upper rod end to release the aft strut from the C345-1 strut weldment.

**8.322 Jackshaft Strut Installation (see Figure 8-9)**

- a) Install lower rod ends to the main rotor gearbox fittings as shown in Figure 8-9.
- b) Reinstall the aft vertical strut upper rod end as shown in Figure 8-9. The rod end extension must be set to  $0.93 \pm 0.03$  inch from the end of the strut to the center line of the rod end ball. (The dimension is the same for all six support rod ends.)
- c) Install jackshaft and push-pull tubes per Section 8.312.
- d) Verify that all bolts and jam nuts are torqued per Section 1.320.

**JACKSHAFT INSTALLATION**

<b>NUMBER</b>	<b>DESCRIPTION</b>
1	Jackshaft Assembly
2	Rod End
3	Washer
4	Nut
5	Palnut
6	Washer
7	Washer
8	Bolt
9	Palnut
10	Nut
11	Bolt
12	Bolt
13	Spacer
14	Washer
15	Tube Weldment
16	Nut
17	Rod End
18	Bolt
19	Washer
20	Nut
21	Palnut
22	Fitting
23	Washer
24	Strut Weldment
25	Spacer
26	Washer (Ref)
27	Push-Pull Tube Assembly (Ref)
28	Push-Pull Tube Assembly (Ref)

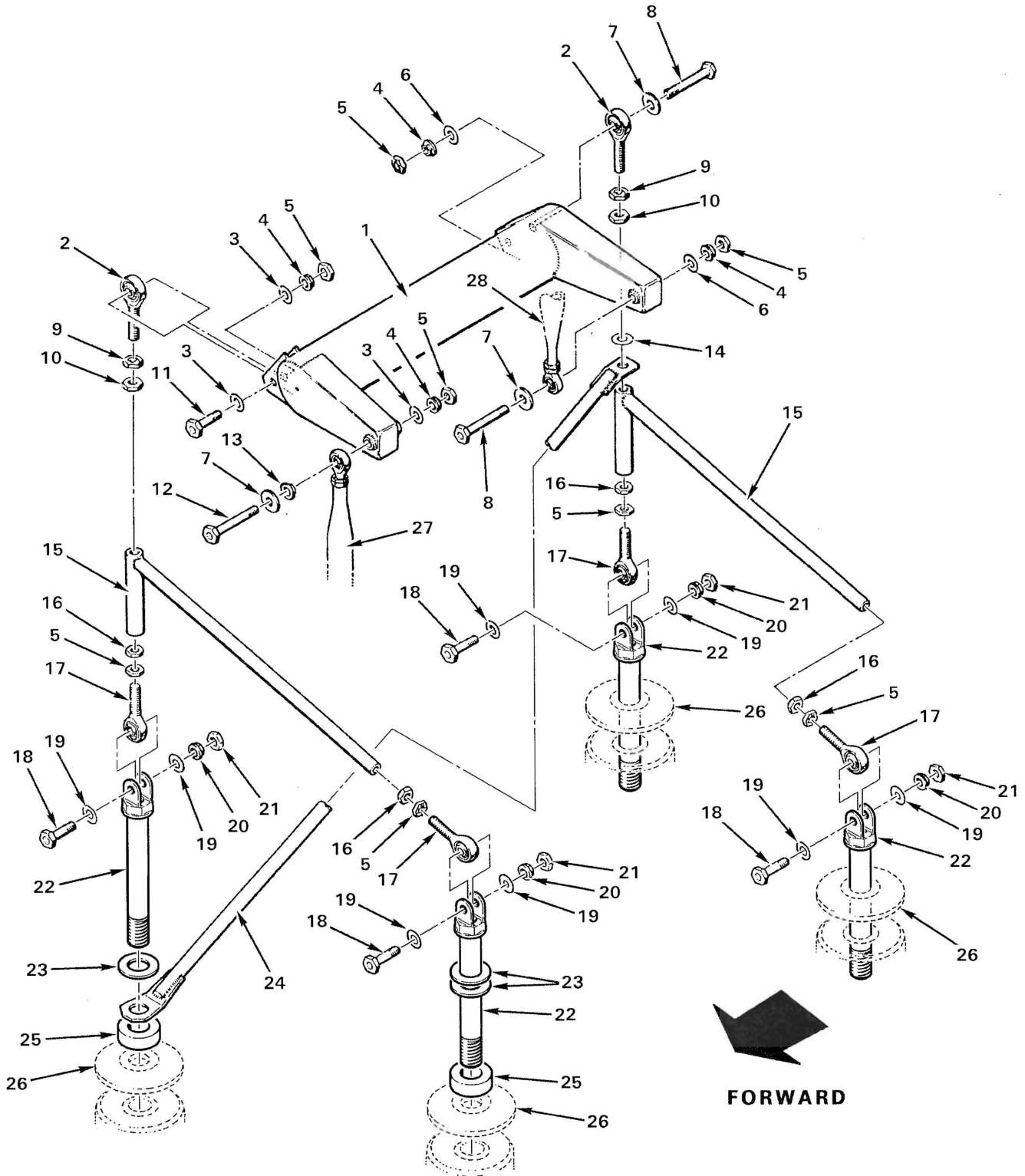

FIGURE 8-9 JACKSHAFT INSTALLATION

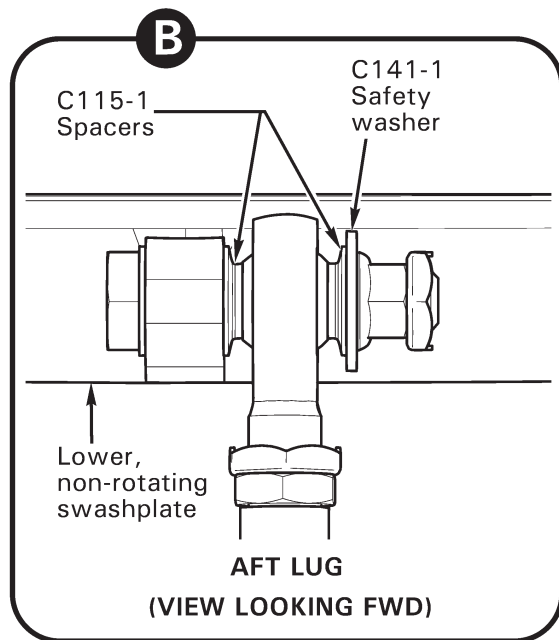
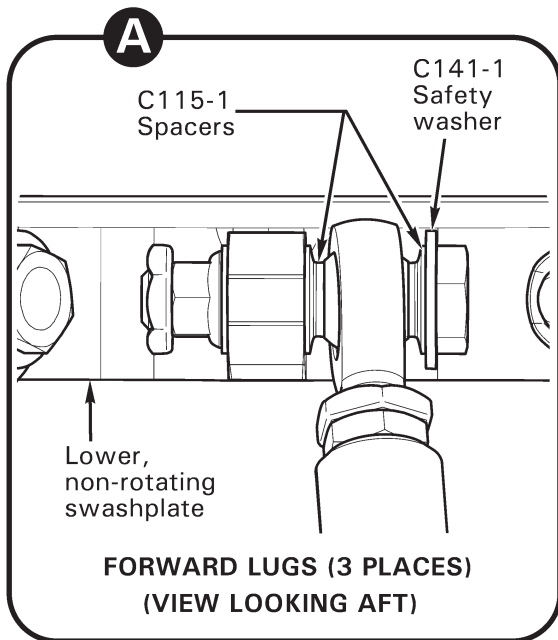
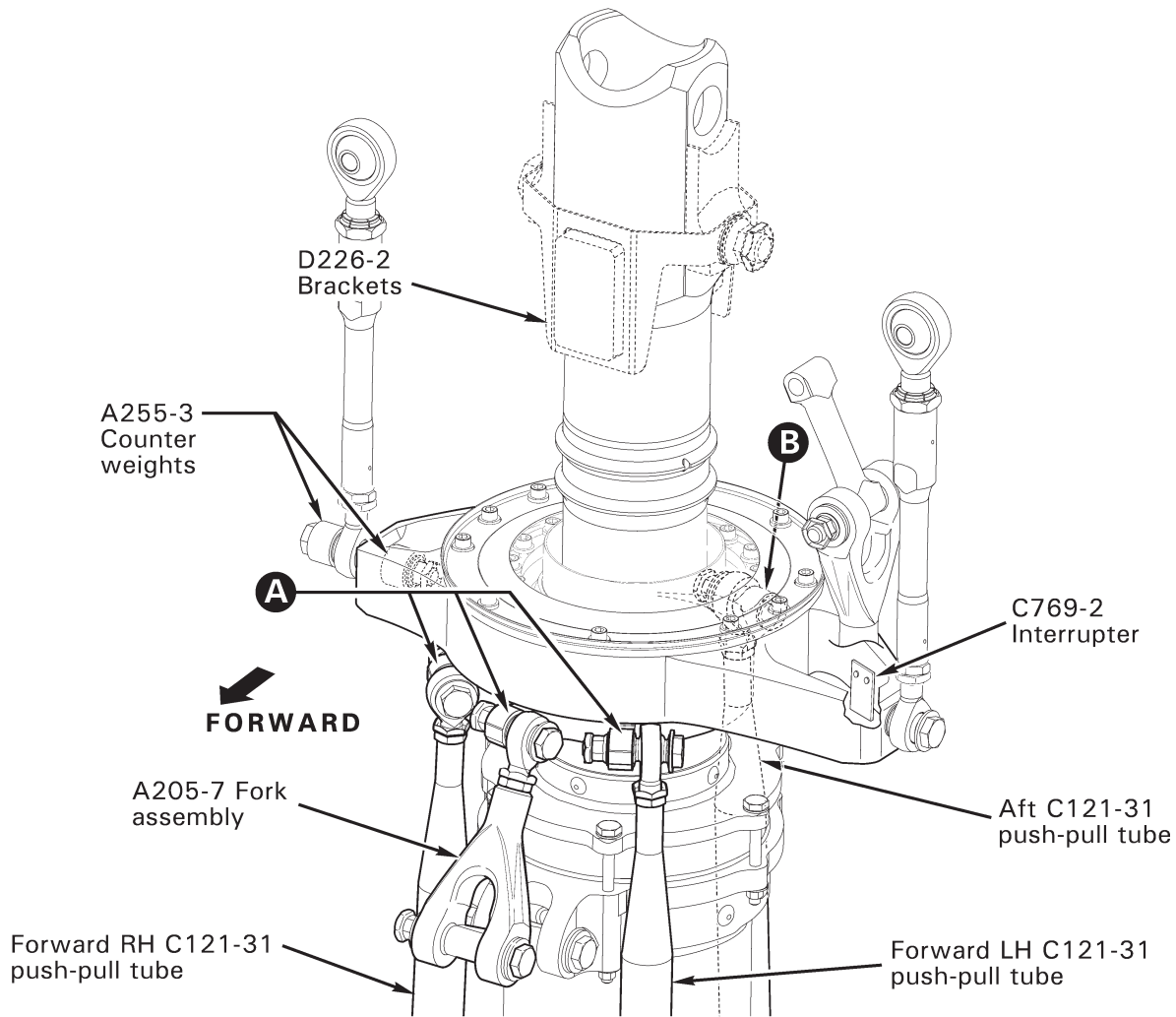

FIGURE 8-10 SWASHPLATE INSTALLATION

## 8.400 Swashplate and Main Rotor Pitch Links

### 8.410 Swashplate

#### 8.411 Swashplate Removal

**NOTE**

Rigging check is not required if push-pull tube rod end center-to-center dimension does not change.

1. Remove main rotor blades and hub per §§ 28-10 and 28-20.
2. Remove NAS6608 bolt & hardware securing C150-1 droop stops and D226-2 teeter stop brackets to C251-2 main rotor shaft. Remove droop stops and brackets.
3. Remove NAS6605 bolt & hardware, including journals & shims, securing upper C204-3 arm to C203-5 yokes.
4. Remove chord arm weights and securing hardware from C203-5 yokes. Record weights removed for reinstallation.
5. Remove hardware securing C203-5 yokes & A210-1 key to main rotor shaft and remove yokes and key.
6. Mark each swashplate ear to match C258-5 or -8 pitch link marking (ref. § 28-10). Remove hardware securing pitch links and A205-7 fork assembly to upper, rotating swashplate and remove from swashplate.
7. Cut & discard ty-raps securing swashplate boot and remove boot.
8. Remove hardware securing three C121-31 push-pull tubes' upper rod ends and A205-7 fork assembly's rod end to lower, non-rotating swashplate.
9. Carefully lift swashplate assembly off slider tube.

#### 8.412 Swashplate Installation

1. If not previously accomplished, install hardware, journals, and shims securing C204-2 lower arm to mast tube assembly. Standard torque bolt per § 23-32, then verify 0.002–0.010-inch axial play in pivot (ref. Figure 2-9); adjust C117 shim thickness between nut-side journal & thrust washer as required. Install stamped nut and standard torque per § 23-32, and torque stripe per Figure 2-1.
2. If not previously accomplished, install hardware, journals, and shims securing lower A205-7 fork assembly to C204-2 lower arm. Standard torque bolt per § 23-32, then verify 0.002–0.010-inch axial play in pivot (ref. Figure 2-9); adjust C117 shim thickness between nut-side journal & thrust washer as required. Install stamped nut and standard torque per § 23-32, and torque stripe per Figure 2-1.

### 8.412 Swashplate Installation (continued)

3. Refer to Figure 8-10. Install hardware securing lower A205-7 fork assembly's rod end, and aft C121-31 push-pull tube's upper rod end, to lower swashplate. Standard torque bolts per § 23-32. Install stamped nuts and standard torque per § 23-32, and torque stripe per Figure 2-1.
4. Refer to § 8.413 and ensure swashplate tilting friction is within allowable limits; adjust swashplate friction as required.
5. Slide swashplate boot over main rotor drive shaft and set in place.
6. Refer to Figure 8-13. Install C203-5 yokes on C251-2 main rotor drive shaft's upper flange; ensure round edge of A210-1 key is inserted into upper flange slot to index yokes to main rotor drive shaft. Finger tighten clamping hardware.

#### CAUTION

NAS6605 bolt securing A210-1 key between yokes must be fully torqued first to obtain proper clamping force.

7. Standard torque NAS6605 bolt securing A210-1 key between yokes per § 23-32. Install stamped nut and standard torque per § 23-32, and torque stripe per Figure 2-1.
8. Standard torque NAS6604 bolt opposite A210-1 key per § 23-32. Install stamped nut and standard torque per § 23-32, and torque stripe per Figure 2-1. A slight gap between yokes opposite A210-1 key is normal.
9. Install hardware securing retained chord arm weights (recorded during removal) to C203-5 yokes. Standard torque bolt per § 23-32. Install stamped nut and standard torque per § 23-32, and torque stripe per Figure 2-1.
10. If not previously accomplished, fill remainder of upper A205-7 fork assembly's rod end threaded hole with B270-13 sealant (ref. § 23-79).
11. Refer to Figure 8-13. Install hardware, journals, and retained shims securing upper C204-3 arm to C203-5 yokes. Standard torque bolt per § 23-32, then verify 0.002–0.010-inch axial play in pivot; adjust C117 shim thickness between nut-side journal & thrust washer as required. Verify arm falls when released from horizontal position. Install stamped nut and standard torque per § 23-32, and torque stripe per Figure 2-1.
12. If not previously accomplished, install hardware, journals, and retained shims securing upper fork assembly to C204-3 arm. Standard torque bolt per § 23-32, then verify 0.002–0.010-inch axial play in pivot; adjust C117 shim thickness between nut-side journal & thrust washer as required. With arm held stationary, verify fork falls when released from horizontal position. Install stamped nut and standard torque per § 23-32, and torque stripe per Figure 2-1.

### 8.412 Swashplate Installation (continued)

13. Refer to Figure 8-10. Install hardware securing two forward C121-31 push-pull tubes' upper rod ends to lower swashplate lugs. Standard torque bolts per § 23-32. Install stamped nuts and standard torque per § 23-32, and torque stripe per Figure 2-1.
14. Align upper swashplate interrupter-side ear to upper A205-7 fork assembly. Install hardware securing upper fork assembly's rod end and correctly matched C258-5 or -8 pitch link's lower rod end to interrupter-side swashplate ear. Standard torque bolt per § 23-32. Install stamped nut and standard torque per § 23-32, and torque stripe per Figure 2-1.
15. Install hardware & two A255-3 counterweights securing correctly matched C258-5 or -8 pitch link's lower rod end to non-interrupter-side swashplate ear. Standard torque bolt per § 23-32. Install stamped nut and standard torque per § 23-32, and torque stripe per Figure 2-1.
16. Position swashplate boot on upper, rotating swashplate and secure in place using MS3367-6-0 ty-rap. With boot upper lip contacting C203-5 yokes, secure in place using MS3367-7-0 ty-rap. Cinch ty-raps until snug without over-tightening, and trim tips flush with heads.

#### CAUTION

Do not drop NAS634-105 bolt or C106-5 journals when aligning droop stops.

17. Temporarily install teeter hinge bolt & nut finger tight with both journals in main rotor shaft. Press each journal against shaft for droop stop alignment.
18. Position C150-1 droop stops and D226-2 brackets & D151-2 teeter stops on main rotor shaft. Ensure droop stops are aligned to teeter bolt's journals and install NAS6608 bolt & associated hardware securing stops and brackets to shaft. Ensure teeter stops are pressed against shaft, then standard torque bolt per § 23-32. Install stamped nut and standard torque per § 23-32, and torque stripe per Figure 2-1.
19. Install main rotor hub and blades per §§ 28-20 and 28-10.
20. Verify no interference with control movement throughout flight control travel, and swashplate movement corresponds with cyclic and collective movement.
21. Perform main rotor track and balance per § 10.230.

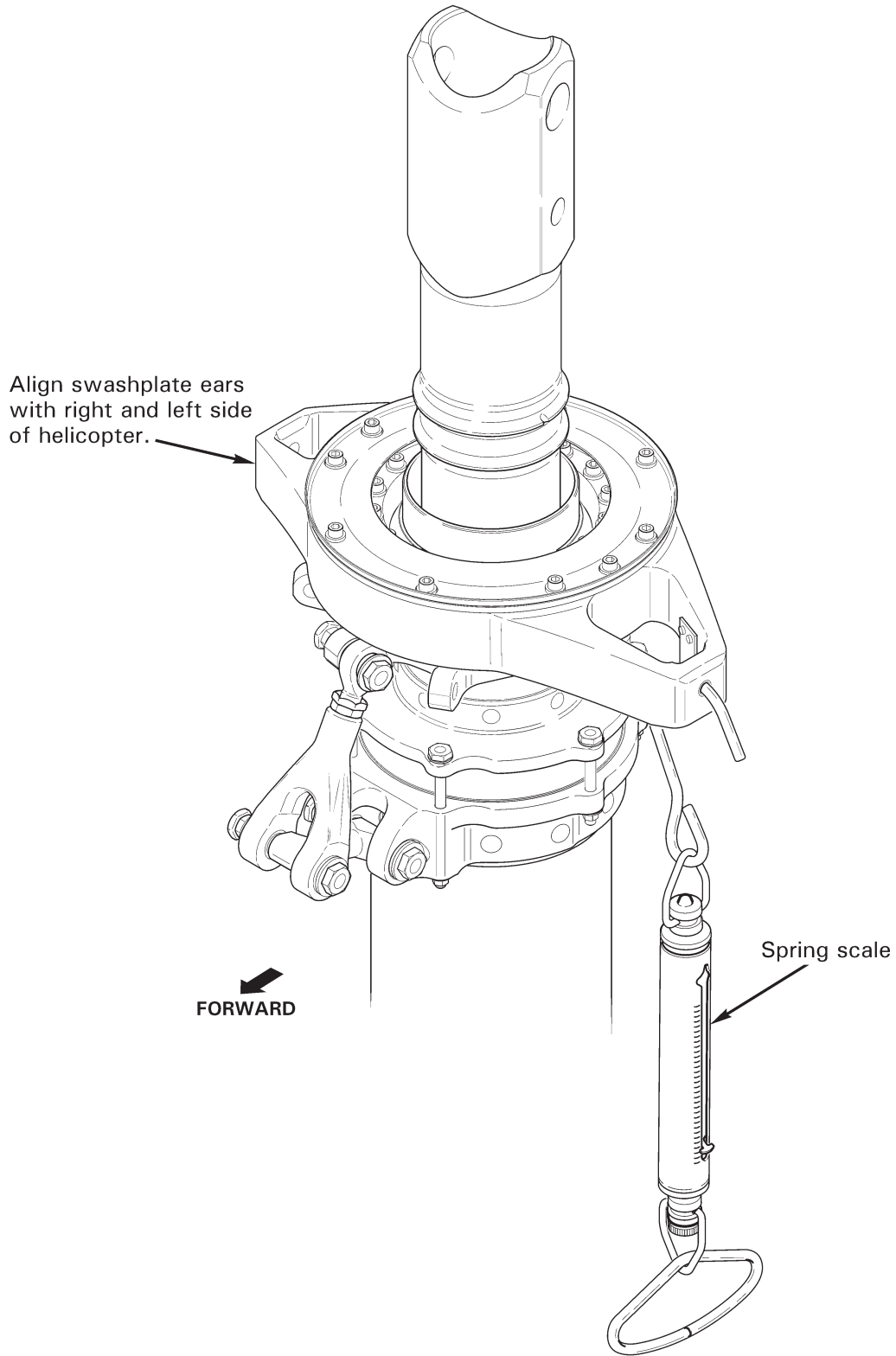
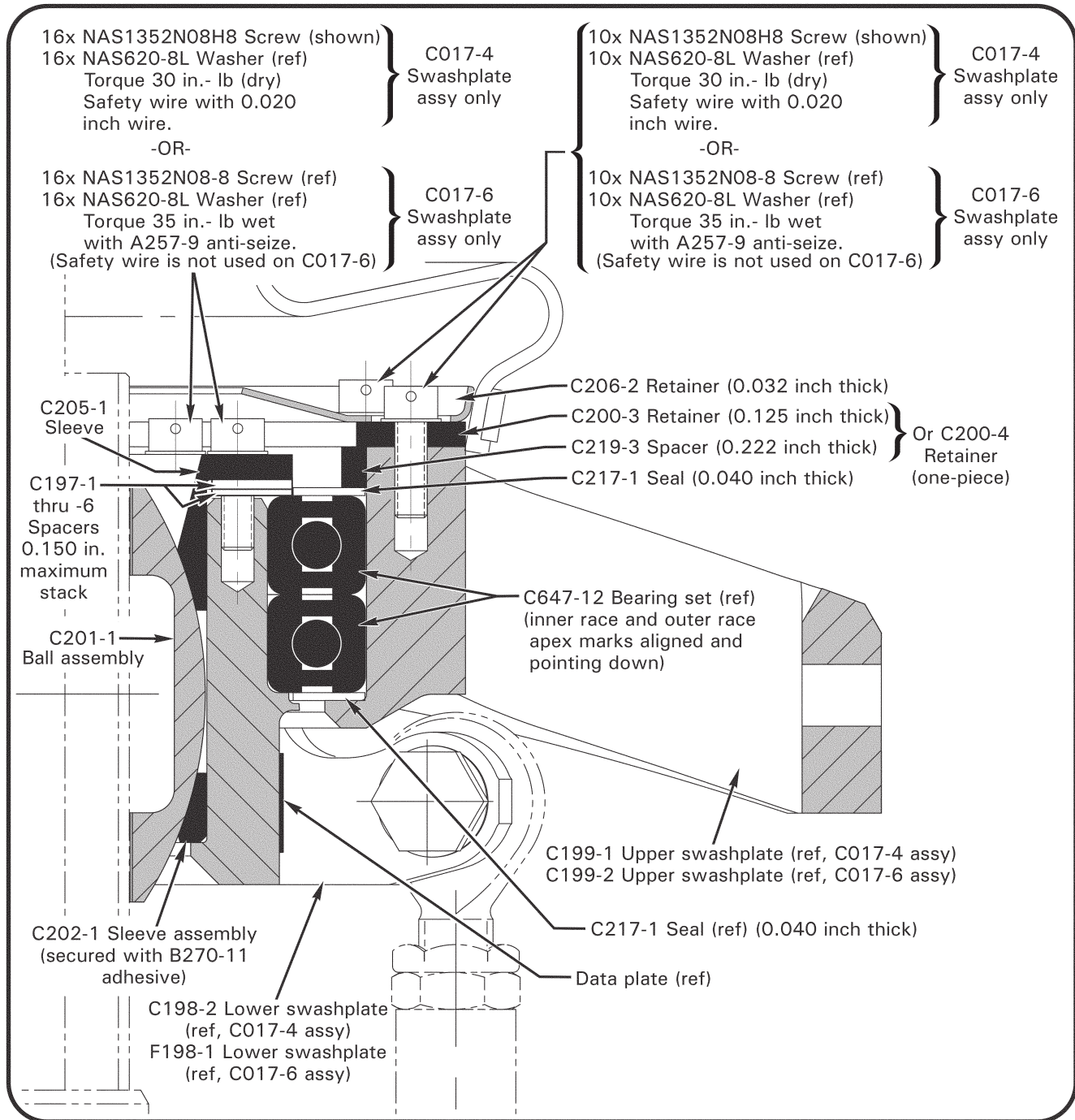

**FIGURE 8-11 MEASURING SWASHPLATE TILTING FRICTION**

### 8.413 Swashplate Tilting Friction Adjustment

Swashplate tilting friction is established by C197-1 through C197-6 spacers controlling clamping force of Teflon-lined sleeves on the ball assembly.

1. Mark for reassembly and disconnect boot, pitch links and drive linkage (scissors) from upper swashplate. Disconnect two forward push-pull tubes from lower swashplate.
2. Refer to Figure 8-11. Align upper swashplate arms with lateral axis of helicopter and center cyclic stick. Using MT359-1 spring scale (or equivalent) connected to upper swashplate arm bolt hole, pull down and note scale reading while swashplate is moving; do not use breakaway reading. For C017-6, force required to tilt swashplate must be between 2 and 7 pounds. For C017-4, force required to tilt swashplate must be free-without-looseness minimum to 5 pounds maximum.
3. Refer to Figure 8-12. To adjust friction, remove outer screws from upper swashplate and raise and secure retainers to allow access to inner screws. Remove inner screws securing sleeve to lower swashplate.
4. Raise sleeve and measure thickness of C197 spacer stack. Adjust spacer stack thickness as required, but not exceeding 0.150 inch, to achieve proper tilting friction. Decreasing spacer stack thickness increases tilting friction while increasing spacer stack thickness decreases tilting friction. All inner screws must be installed and special torqued per § 23-33 prior to measuring friction.
5. As required, safety wire inner screws with 0.020 inch diameter safety wire. Secure retainers to upper swashplate with outer screws, special torque per § 23-33, and safety wire as required.
6. Refer to Figure 8-10. Install hardware securing two forward C121-31 push-pull tubes' upper rod ends to lower swashplate lugs. Standard torque bolts per § 23-32. Install stamped nuts and standard torque per § 23-32, and torque stripe per Figure 2-1.
7. Align upper swashplate interrupter-side ear to upper A205-7 fork assembly. Install hardware securing upper fork assembly's rod end and correctly matched C258-5 or -8 pitch link's lower rod end to interrupter-side swashplate ear. Standard torque bolt per § 23-32. Install stamped nut and standard torque per § 23-32, and torque stripe per Figure 2-1.
8. Install hardware & two A255-3 counterweights securing correctly matched C258-5 or -8 pitch link's lower rod end to non-interrupter-side swashplate ear. Standard torque bolt per § 23-32. Install stamped nut and standard torque per § 23-32, and torque stripe per Figure 2-1.
9. Position swashplate boot on upper, rotating swashplate and secure in place using MS3367-6-0 ty-rap. With boot upper lip contacting C203-5 yokes, secure in place using MS3367-7-0 ty-rap. Cinch ty-raps until snug without over-tightening, and trim tips flush with heads.



**FIGURE 8-12 SWASHPLATE ASSEMBLY**

Intentionally Blank

8.500 Tail Rotor Controls8.510 Tail Rotor Pedals8.511 Tail Rotor Pedal Removal

1. Remove carpet to access pedal covers per § 15.310 or § 15.320 as required.
2. Remove screws between pedals securing access plates to floor and remove plates.
3. Open or remove console as required per § 13-80. If applicable, disconnect intercom system controller and outside air temperature gage wiring.
4. Remove radios, radio face plate and radio rack by removing screws securing rack to sides of console.

## 8.511 Tail Rotor Pedal Removal (cont'd)

5. Disconnect both pedal assemblies from the C343-3 and C343-5 push-pull tubes by removing two NAS6604-9 bolts.

**CAUTION**

DO NOT remove the rod ends or change the length of the push-pull tubes.

6. Remove six NAS6603-20 bolts (three per side) which hold the A318-1 and -2 bearing block halves together.
7. Remove the lower bearing block halves.
8. Remove the tail rotor pedals one at a time by lifting one end and allowing the other to drop into the chin. They can be removed from either the right or the left side.

**NOTE**

On reassembly, the right pedal assembly is mounted forward in the bearing blocks and the left is mounted aft.

**NOTE**

Pedal blocks (upper and lower) are a machined matched set as indicated by matching letter or number on the upper and lower portion of blocks. DO NOT mix them or alignment problems may develop on installation.

## 8.512 Tail Rotor Pedal Installation

1. Fill the grooves in the pedal bearing blocks with A257-1 grease.
2. Install the pedal assemblies into the bearing blocks and torque the bearing block attach bolts per Section 1.320.

**NOTE**

If a force greater than 5 lbs is required to move pedals, check the bearing blocks to ensure they are matched correctly.

3. Connect both pedal assemblies to the push-pull tubes and torque the NAS6604-9 bolts to per Section 1.320 and install palnuts.
4. Install radio racks, radios and radio panel face plate.
5. Move the pedals through the full range of travel to ensure there is no interference or binding.
6. Secure console. Install the pedal cover plates and carpeting. Use B270-7 or -8 adhesive to attach carpeting.

### 8.520 C317 Lower Bell Crank

#### 8.521 C317-2 Lower Forward Bell Crank Removal

- a) Remove two screws securing the upper console. Lift up the console and disconnect intercom system controller and outside air temperature gauge wiring.
- b) Remove radios, radio panel face plate and the radio rack which is secured with screws to the side panels.
- c) Disconnect forward C343-3 and C343-5 push-pull tubes and aft C121-9 push-pull tube from the bell crank by removing all three NAS6604-9 bolts.
- d) Remove four MS27039C0807 screws which secure the C349-1 support assembly to the forward keel panel.
- e) Remove support and bell crank assembly from the ship.
- f) Remove NAS6604-19 bolt which connects the bell crank to the support. Remove bell crank.

#### 8.522 C317-2 Lower Forward Bell Crank Installation

This procedure also covers rigging of the lower push-pull tubes and pedal assemblies. If re-checking of rigging is not required, disregard rigging portions and follow installation sequences.

- a) Install two A105-3 journals inside C317-2 bell crank. Place one A141-3 washer against the outside ends of the A105-3 journals upon assembly to the support.

Tighten pivot nut and check for smooth and free operation. Maximum spring scale drag of 2 lbs is acceptable to move the bell crank. Torque per Section 1.320.

If a force in excess of 2 lb is required to move the bell crank measure the distance between the A141-3 washers with the washers held tightly against the journals. Using a one inch diameter spotface tool with a 0.250 inch pilot in one A105-3 journal, lightly shave the outside face of each bearing 0.002 inch - 0.003 inch at a time. Assemble the bell crank on the support assembly. If a force in excess of 2 lb is required to move the bell crank, repeat above step.

- b) Install the support assembly in the ship and secure it to the keel panels with four MS27039C0807 screws. Adjust the length of C343-3 push-pull tube rod ends center-to-center to 4.42 inch and adjust C343-5 rod ends center-to-center to 6.45 inch. Verify that the rod ends are engaged sufficiently by checking the witness holes with a piece of 0.020 inch safety wire.

## 8.522 C317-2 Lower Forward Bell Crank Installation (cont'd)

Connect all three push-pull tubes to C317-2 bell crank. Do not torque the NAS6604-9 bolts yet. The length of C121-9 push-pull tube must be set to 66.0 inch. Ensure the 121-9 push-pull tube is installed through the center of the C346-1 restraint at the mid span position.

The vertical C343-1 push-pull tube which connects C317-1 aft bell crank to C316-1 upper bell crank must measure 13.40 in. rod end center-to-center.

Connect fwd end of C121-9 push-pull tube to the C317-2 fwd bell crank and the aft end to C317-1 bell crank. Tighten the bolts but do not torque them yet. Connect one end of C343-1 push-pull tube to the C317-1 aft bell crank and the other end to C316-1 upper bell crank. Tighten the bolts but do not torque them yet.

Install a 3/16 inch diameter pin through the rigging hole located in the right aft passenger cargo compartment and push it through C317-1 bell crank's rigging hole. With rigging pin installed, adjust lengths of C121-9 and C343-3 push-pull tubes to obtain 2.90 in. between right pedal and right-hand stop.

After adjusting pedal travel, remove the rigging pin and apply full left pedal. With left pedal at stop, adjust length of C343-1 to obtain 0.10 - 0.20in. from C121-15 forward rod end to bulkhead. With left pedal at stop, adjust length of C121-17 push-pull tube to obtain  $0.35 \pm 0.03$  inch between C031-1 pitch control assembly and face of the tail rotor gearbox end cap. Check all push-pull tube rod ends witness holes for engagement.

## NOTE

It is permissible for the bell crank arm to touch and deflect acoustical foam, as long as it does not interfere with free movement and full travel of the controls.

- c) Torque all attaching bolts per Section 1.320. Install palnuts and torque stripe fasteners.

**8.522 C317-2 Lower Forward Bell Crank Installation (cont'd)**

- d) Check for smoothness and ease of operation. Move pedals full travel. Check for any interference between tubes, wires and structure.
- e) If required, check complete tail rotor rigging if changes to C343-1, C343-3, C343-5, C121-9, C121-15 or C121-17 push-pull tube lengths have been made.
- f) Verify all attach bolts and jam nuts torqued per Section 1.300.
- g) Install radio rack, radio face plate, radios and all the panels which were removed.

**8.523 C317-1 Lower Aft Bell Crank Removal**

- a) Install collective spring retainer or safety wire the collective spring per Section 8.221.
- b) Remove collective spring per Section 8.221.
- c) Disconnect C121-9 and C343-1 push-pull tubes by removing respective NAS6604 bolts from the C317-1 bell crank.
- d) Disconnect A205-3 fork assembly from the C326-1 bell crank assembly by removing NAS6604-38 bolt. Leave friction assembly connected to C315-1 upper support.
- e) Remove NAS6604-9 bolt and disconnect C121-19 collective push-pull tube from the C326-1 bell crank.
- f) Remove four NAS6604-2 bolts which are securing C315-1 rear support assembly to the left and right panels. Remove C334 assembly.
- g) C317-1 aft bell crank is connected to rear support assembly by C311-1 bolt which is common to C317-1 to C326-1 bell cranks. Remove the bolt and remove C317-1 aft bell crank.

### 8.524 C317-1 Lower Aft Bellcrank Installation

- a) Install C317-1 aft bellcrank on C315-1 or C315-7 rear support assembly with NAS6604-105 bolt, one NAS1149F0432P washer under head and two NAS1149F0463P washers under nut. Standard torque bolt per Section 1.320, install & torque palnut, and torque stripe per Figure 2-1.
- b) Install C334 rear support assembly in ship and secure it to side panels with four NAS6604-2 bolts. Standard torque bolts per Section 1.320, and torque stripe per Figure 2-1.
- c) Connect C343-1 and C121-9 push-pull tubes to the C317-1 tail rotor control aft bellcrank. Connect the C121-19 push-pull tube to C326-7, C326-8, or C334-4 bellcrank. Verify A697-6 tab oriented 0° to 20° outboard from vertical. Standard torque bolt per Section 1.320, install & torque palnut, and torque stripe per Figure 2-1.
- d) Set upper A205-3 fork assembly center-to-center distance to 3.80 inch  $\pm$  0.03 inch. Reconnect A205-3 fork assembly to C326-7, C326-8, or C334-4 bellcrank.
- e) If applicable, set collective-friction rod end link assembly center-to-center to 2.300 inches  $\pm$  0.010 inch (C327-1 collective-friction link assembly is not adjustable). Install bolts and standard torque per Section 1.320. Install & torque palnuts, and torque stripe per Figure 2-1.
- f) If applicable, connect bottom rod end of collective spring assembly to C326-7, or C326-8 support assembly per Section 8.222. Standard torque bolt per Section 1.320, install & torque palnuts, and torque stripe per Figure 2-1. Remove retainer from spring.
- g) Move pedals and check for smoothness and ease of operation. Move pedals, collective, and cyclic full travel, and verify no interference between tubes, bellcranks, wires and structure.

### 8.530 C316-1 Upper Bellcrank

#### 8.531 Bellcrank Removal

- a) Remove aft vertical panel between seat backs and right rear seatback.
- b) Disconnect C343-1 push-pull tube from the bellcrank assembly by removing the NAS6604-8 bolt.
- c) Disconnect C121-15 push-pull tube from C316-1 bellcrank by removing NAS6604-8 bolt.
- d) Disconnect C316-1 bellcrank from aircraft by removing NAS1304-17 bolt from inboard support and NAS6604-11 bolt from outboard support.

## 8.532 Bellcrank Installation

- a) Install bellcrank with NAS1304-17 bolt through bearing block and then through bellcrank and NAS6604-11 bolt connecting bellcrank to outboard support. Torque bolts per Section 1.320. Install palnuts, torque per Section 1.320 and torque stripe per Figure 2-1.
- b) Reconnect forward end of C121-15 push-pull tube and upper rod end of C343-1 push-pull tube to C316-1 bellcrank. Torque bolts per Section 1.320. Install palnuts, torque per Section 1.320 and torque stripe per Figure 2-1.

## NOTE

If rod ends, of C121-15 and C343-1 push-pull tubes, were removed or length of push-pull tubes were altered re-rig tail rotor blades per Section 10.140.

8.540 A331-4 Intermediate Bellcrank (See Figure 8-14)

## 8.541 Bellcrank Removal

- a) Disconnect C121-15 and -17 push-pull tubes from A331-4 bellcrank.
- b) Disconnect NAS6604-35 attach bolt and remove bellcrank.

## 8.542 Bellcrank Installation

- a) Install two A105-3 journals into bellcrank bearings. One A141-3 washer is required on each side of bellcrank against A105-3 journals (If required, ream A139-1 bearing with 0.375/0.376 in. dead-sharp reamer for journal's smooth installation).
- b) Install bolt and torque per Section 1.320. Install palnut, torque per Section 1.320 and torque stripe per Figure 2-1.
- c) Check for smoothness and ease of operation.
- d) Connect A121-15 and -17 push-pull tubes. A214-3 safety washer is required under the bolt head which connects C121-15 push-pull A331-4 tube to the bellcrank and one MS20002-4 washer is required between the rod end ball and the bellcrank.
- e) A214-3 safety washer is required between bolt head and forward rod end of C121-17 push-pull tube.
- f) Re-rig tail rotor per Section 10.140 if push-pull tube lengths were altered.

**8.542 Bell Crank Installation (cont'd)**

- e) Move pedals full travel, check for any interference between tubes, wire, components or structure.

**8.550 A120-3 Aft Bell Crank****8.551 Bell crank Removal**

- a) Disconnect C121-17 push-pull tube from A120-3 aft bell crank.
- b) Disconnect bell crank pivot from attach bolt connected to tail rotor gearbox.
- c) Remove nut holding bell crank to the pitch control. Remove bell crank and reinstall nut and shims found between bell crank and pitch control for bell crank installation.

**8.552 Bell Crank Installation**

See C031-1 Pitch Control Installation (see Section 8.562).

**8.560 C031-1 Pitch Control****8.561 Pitch Control Removal**

- a) Remove tail rotor hub and blade assembly. Mark corresponding tail rotor blade grips, tail rotor pitch change to each of the pitch control ears, for later reinstallation so re-rigging is not required.
- b) Disconnect and remove A120-3 aft bell crank per Section 8.551.
- c) Remove C031-1 pitch control from tail rotor output shaft.

**8.562 Pitch Control Installation**

- a) Slide C031-1 pitch control assembly onto output shaft.
- b) Position A120-3 bell crank assembly on the tail rotor gearbox and install NAS6604-25 bolt, one AN960-416L washer under bolt head, two MS20002-4 washers, one on each side of the bearing and MS21042-4 nut. Tighten but don't torque at this time.
- c) Measure the gap existing between the A120-3 bell crank ear and the flats on the C125-1 pitch control stud. Install sufficient C117-34, -35 and -36 washers between bell crank and stud to completely fill the gap but not apply any axial preload on the spherical bearing after all the nuts are tightened. The clearance tolerance is  $\pm 0.003$ ". Install one AN960-516L washer and MS21042-5 nut on protruding end of stud. Torque nut to 200 in.-lb plus nut drag while holding stud from rotating, and install palnut.

**8.562 Pitch Control Installation (cont'd)**

- d) Torque nut on A120-3 bellcrank pivot per Section 1.320 and install palnut.
- e) Attach aft end of C121-17 push-pull tube to the A120-3 bellcrank with NAS6604-10 bolt, AN960-416L under head, and A214-3 safety washer under nut next to rod end. Torque nut per Section 1.320 and install palnut.
- f) Install pitch control links per Section 8.572.
- g) Install tail rotor hub and blade assembly (see Section 9.212).
- h) Ensure all bolts, jam nut and palnuts are torqued per Section 1.300.

**8.570 Tail Rotor Pitch Links****8.571 Tail Rotor Pitch Link Removal****NOTE**

To ensure proper rigging upon reinstallation of pitch links, mark pitch links to corresponding blade grip and pitch control ear.

- a) Disconnect the two attach bolts on both rod ends of the pitch link.
- b) Remove pitch link.

**8.572 Tail Rotor Pitch Link Installation****WARNING**

A214-3 safety washers are to be installed next to each rod end.

**CAUTION**

One-piece tail rotor pitch links must be used in sets. DO NOT use one-piece pitch links with adjustable pitch links.

**NOTE**

If installing same pitch links, match pitch link to proper blade grip and pitch control ear. If installing new, adjustable pitch links, measure overall length of old pitch link with micrometer or caliper. Adjust the new pitch link to the measurement obtained within 1/2 turn of the rod end.

8.572 Tail Rotor Pitch Link Installation (cont'd)**WARNING**

**Both pitch links must be same part number (same type and material). Mixing one-piece with adjustable-length pitch links is prohibited. Mixing steel one-piece with aluminum one-piece pitch links is prohibited.**

Refer to Figure 9-11.

A. If installing one-piece pitch link(s):

1. Connect pitch link to pitch control arm and blade pitch horn.
2. Torque attach bolts per Section 1.320. Install palnuts, torque per Section 1.320, and torque stripe per Figure 2-1. Repeat for opposite blade.

B. If installing new, adjustable-length pitch link(s) based on old pitch link length:

1. Match pitch link to proper blade pitch horn and pitch control arm and connect pitch link. Torque attach bolts per Section 1.320. Install palnuts, torque per Section 1.320, and torque stripe per Figure 2-1. Repeat for opposite blade.
2. Torque attach bolts per Section 1.320. Verify proper rod end centering and adjust as required. Install palnut, torque per Section 1.320, and torque stripe per Figure 2-1. Repeat for opposite blade.
3. Check tail rotor control rigging per Section 10.140.

C. If installing new, adjustable-length pitch links (nominal length setting):

1. Assemble male rod end, with jam nut and palnut installed, into female rod end. Adjust rod ends until a dimension of  $2.620 \pm 0.010$  inches, measured between rod end bearing centers.
2. Attach pitch link female rod end to outboard side of pitch control arm. Torque bolt per Section 1.320. Install palnut, torque per Section 1.320, and torque stripe per Figure 2-1.
3. Connect pitch link male rod end to blade pitch horn. NAS1149F0432P, NAS1149F0463P, A214-3 or A141-14 washers may be under nut for chordwise balance. Torque bolt per Section 1.320. Install palnut, torque per Section 1.320, and torque stripe per Figure 2-1.
4. Torque pitch link jam nut and palnut per Section 1.320 and torque stripe per Figure 2-1. Repeat steps 1 thru 4 for opposite blade.
5. Check tail rotor control rigging per Section 10.140.

**8.600 C203 YOKE AND A205 FORK ASSEMBLY****8.610 Bearing Removal**

B115-1 Spherical bearings and C648-2 journal bearings may be removed with a press. Press from inner side of bearings while supporting outboard side of yoke or fork. Use a socket or other suitable pressing tool to apply the force.

**8.615 C648-2 Bearing Installation (0.5625/0.5630 inch diameter bearing bores)**

1. Clean mating surfaces of A205 fork or C203 yoke where C648 bearing is installed. Deburr any sharp edges that may damage bearings during installation.
2. Coat yoke or fork bearing bores with zinc chromate or epoxy primer. While primer is still wet, press in C648 bearing while supporting backside of fork or yoke.

**8.620 B115-1 Bearing Installation**

1. Press out old bearings.
2. Clean yoke or fork assembly bearing bores of old adhesive.
3. Measure bearing bores; maximum allowable diameter is 0.6260 inches.
4. Lightly coat B115-1 bearing outer races with B270-10 adhesive and install B115-1 bearings into bearing bores. Wipe off excess adhesive. Do not allow adhesive to enter B115-1 bearing itself.
5. While adhesive is still wet, assemble yoke or fork assembly per Section 8.412. Wait until adhesive has been allowed to cure per manufacturer's instructions prior to checking bearing pivot force.



Intentionally Blank

Intentionally Blank

Intentionally Blank

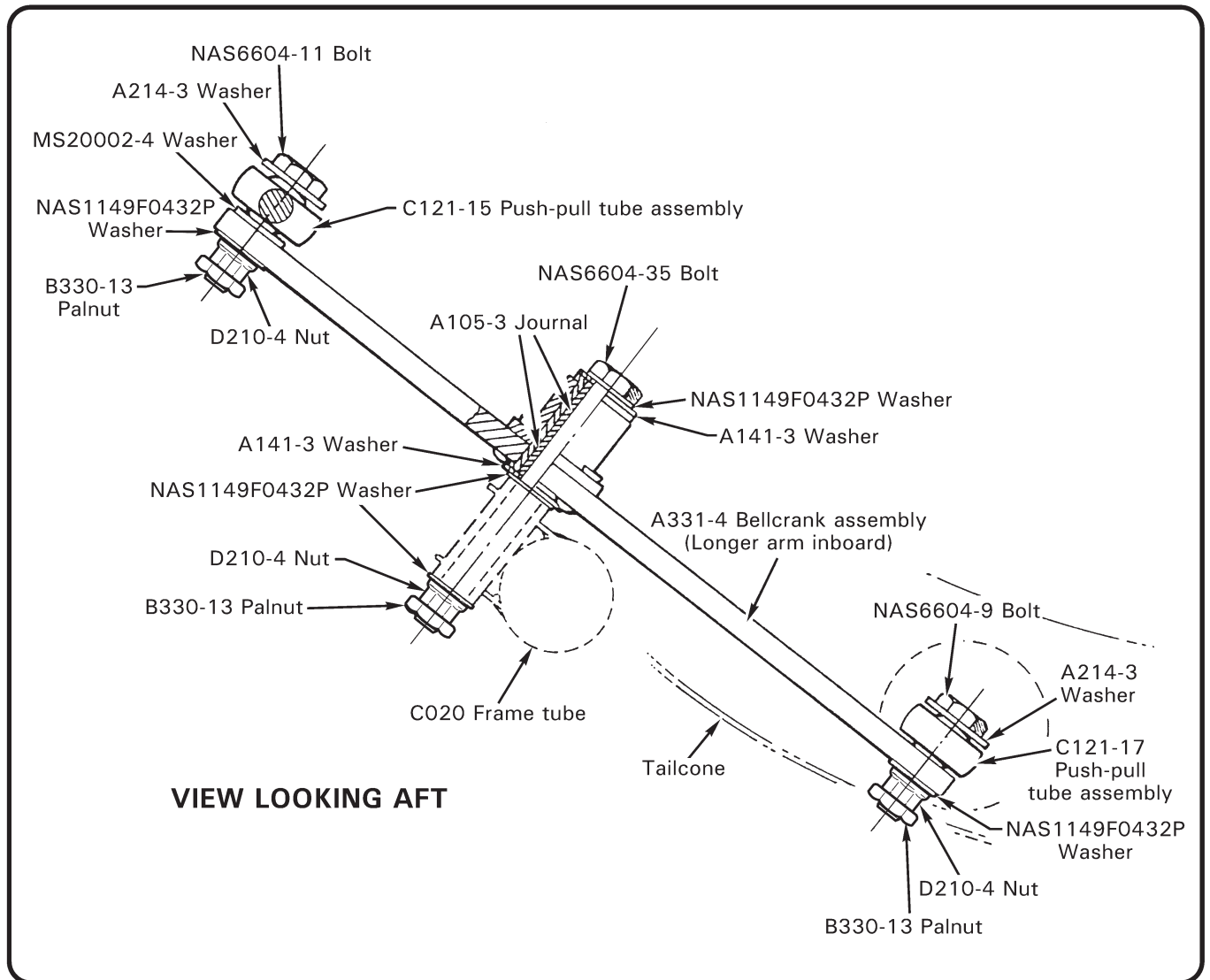

**FIGURE 8-14 A331-4 BELLCRANK INSTALLATION**

**CORRECT ALIGNMENT**



**INCORRECT ALIGNMENT**



**MS28773 Retainers**  
(Diagonal split)

MS28773 Retainers, installed on hydraulic system fittings, are superseded by D454 Retainers. Verify correct alignment of diagonal split if installing new MS28773 Retainers. MS28773 Retainers ARE NOT reusable.



**D454 Retainers**  
(Straight split)

D454 Retainers, installed on hydraulic system fittings, supersede MS28773 Retainers. D454 Retainers have a straight split to eliminate installation error, and are more rigid for better sealing. D454 Retainers ARE reusable.

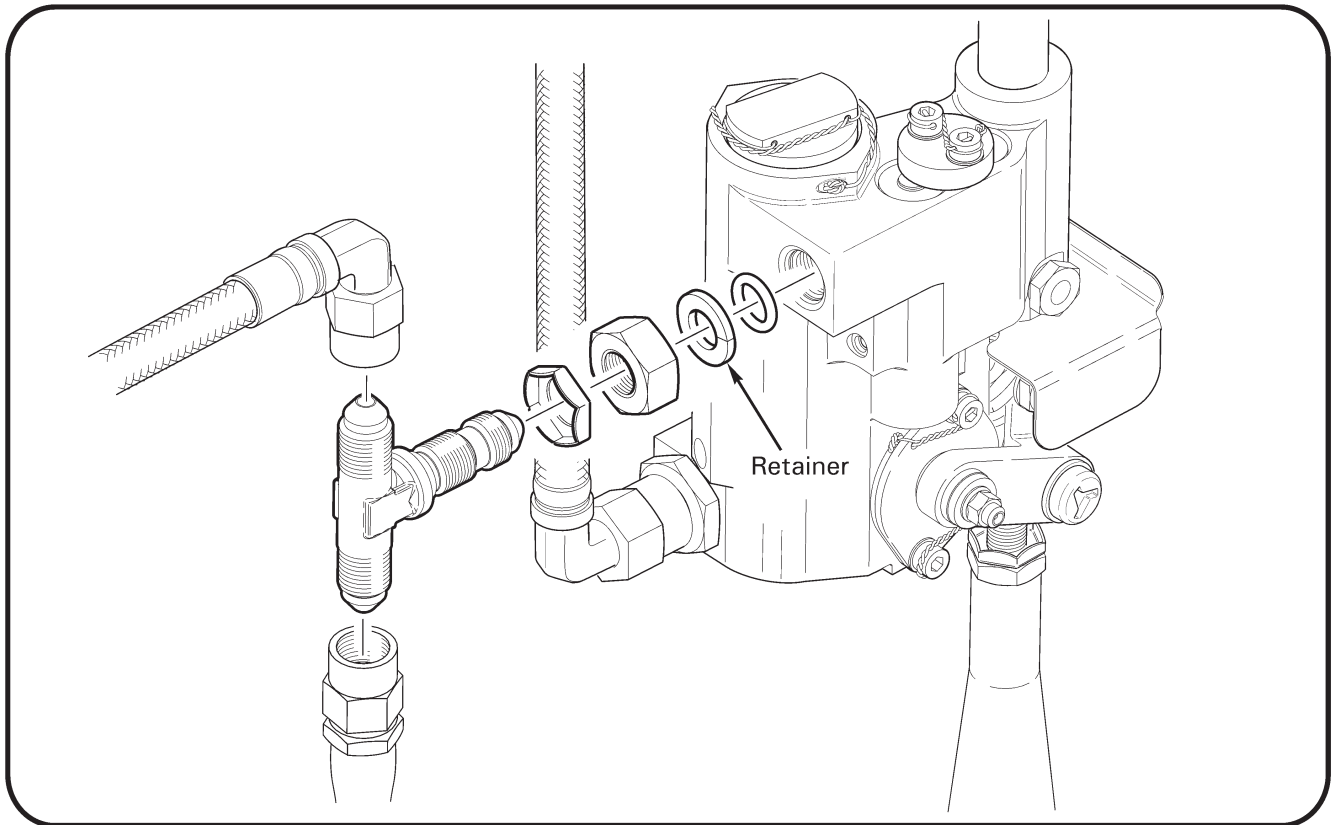

**FIGURE 8-16 HYDRAULIC FITTING O-RING RETAINERS**

### 8.700 Hydraulic Flight Controls

#### 8.710 Hydraulic Reservoir Removal

**CAUTION**

Use LPS PreSolve to clean hydraulic parts. Do not use alcohol.

1. Refer to Figure 8-1A. Remove C706-1 tailcone cowling.
2. Place a one-liter container beneath suction line fitting on reservoir. Disconnect and cap suction line at reservoir aft elbow and allow reservoir fluid to drain into container.
3. Disconnect and cap one return and two pressure lines from reservoir elbows.
4. Disconnect pump bypass solenoid electrical connector.
5. Cut safety wire from and remove four drilled-head bolts securing reservoir to upper frame. Remove reservoir.

#### 8.720 Hydraulic Reservoir Installation

**CAUTION**

Use LPS PreSolve to clean hydraulic parts. Do not use alcohol.

1. Refer to Figures 8-1A and 8-16. Install elbows into reservoir with palnuts, jam nuts, retainers, and O-rings.
2. Point forward elbows up. Torque jam nuts and palnuts per Section 1.330. Forward elbows are different sizes and nuts require different torques.
3. Position reservoir on upper frame and install four drilled-head bolts. Torque bolts per Section 1.330 and safety wire.
4. Connect servo pressure and return lines to forward elbows and torque per Section 1.330. Torque stripe jam nuts, palnuts, and B-nuts.
5. Connect pump bypass solenoid electrical connector and ty-rap wires as required.
6. Connect pump suction line to aft (suction) elbow. Position elbow to minimize preload on suction line. Torque jam nut, palnut, and B-nut per Section 1.330 and torque stripe.
7. Connect pump pressure line to remaining elbow. Position elbow to minimize preload on pressure line. Torque jam nut, palnut, and B-nut per Section 1.330 and torque stripe.
8. Verify line and servo clearance to surrounding structure while flight controls are moved through full range of travel.
9. Verify reservoir cooling hose is secure and directed at center of reservoir cooling fins. Adjust as required.

8.720 Hydraulic Reservoir Installation (continued)

10. Fill reservoir with A257-15 (see Section 1.470) fluid.

**CAUTION**

Cleanliness of hydraulic fluid is vital to proper system operation. Use only clean fluid from sealed containers and avoid contamination from dirty funnels, tubing, etc.

11. Secure C706-1 tailcone cowling and connect any attached antenna.
12. Bleed hydraulic system per Section 1.190.

8.730 Hydraulic Pump Removal**CAUTION**

Use LPS PreSolve to clean hydraulic parts. Do not use alcohol.

1. Remove auxiliary fuel tank per Section 12.121.
2. Refer to Figure 8-1A. Remove reservoir filler-vent.
3. Cover reservoir filler-vent hole with finger to prevent fluid loss. Disconnect and cap suction line at hydraulic pump forward T-fitting.
4. Disconnect and cap pressure line at hydraulic pump aft T-fitting.
5. Remove four self-locking nuts and washers securing pump to gearbox.
6. Remove pump, phenolic insulator if installed, and o-ring. Discard o-ring. Do not remove metal cartridge.

### 8.740 Hydraulic Pump Installation

**CAUTION**

Use LPS PreSolve to clean hydraulic parts. Do not use alcohol.

1. Refer to Figures 8-1A and 8-16. Install palnuts, jam nuts, retainers, and new o-rings on T-fittings and install T-fittings in pump. Ensure lower arm of both T-fittings is capped.

**CAUTION**

Verify retainers have been installed per Figure 8-16. Improper installation will result in loss of hydraulic fluid.

2. Lubricate new o-ring with A257-2 gearbox oil and install on pump mounting flange. If C267 cartridge in MRGB has 0.125 inch thick flange then also install phenolic insulator on pump mounting flange. Install pump on gearbox studs so larger T-fitting is forward. Install washers and self-locking nuts on studs and special torque per Section 1.330.
3. Position pump T-fittings so that outlets are approximately 45° from vertical with top pointing inboard. Special torque jam nuts and palnuts per Section 1.330. Nuts are different sizes and require different torques.
4. Connect reservoir pressure hose to pump pressure (aft) T-fitting. Special torque B-nut per Section 1.330.
5. Cover reservoir filler-vent hole with finger to prevent fluid loss. Remove plug from suction hose and connect hose to pump suction (forward) T-fitting. Special torque B-nut per Section 1.330.
6. Install auxiliary fuel tank per Section 12.122 and verify minimum 0.25 inch clearance with hydraulic hoses and fittings. Reposition hoses and fittings as required.
7. Torque stripe jam nuts and B-nuts per Figure 2-1.
8. Bleed hydraulic system per Section 1.190.
9. Install a 110-4 Telatemp on easily visible surface of pump.

### 8.750 Hydraulic Servo Removal

**CAUTION**

Do not pressurize hydraulic system while any hydraulic system component is disconnected or removed.

1. Remove mast fairing and C706-1 tailcone fairing assembly. Remove aft belly panel.
2. Refer to Figures 8-1A and 8-1C. Perform the following measurements on all D212-1 hydraulic servo assemblies to be removed:
  - a. Measure & record dimension between D200-1 clevis hole center & top of servo piston shaft.
  - b. Apply cyclic and collective frictions. With collective full down and hydraulics unpressurized, manipulate cyclic stick so piston in servo to be removed is in its lowest position. Measure & record dimension between top of servo piston shaft and top of cylinder assembly.

**CAUTION**

Dimension between clevis hole center and top of servo piston shaft must be  $1.40 \pm 0.03$  inches; dimension between top of servo piston shaft and top of cylinder assembly must be  $0.28 \pm 0.03$  inch. If dimensions are not within required range, perform main rotor rigging per Section 10.120 after servo installation.

3.
  - a. Forward Right Servo: Remove aux fuel tank per Section 12.121.
  - b. Forward Left Servo: Remove main fuel tank per Section 12.111.
4. Remove hardware securing servo clevis to C121-25 or -31 push-pull tube's lower rod end.
5.
  - a. Forward Servo: Mark (right or left) position of C121-24 or -28 push-pull tube's. Loosen jam nut and palnut securing tube to servo's lower rod end, and remove hardware securing tube's lower rod end to C175-4 cyclic pivot assembly. Count and record number of turns required to unscrew tube from servo's lower rod end.
  - b. Aft Servo: Remove hardware securing C343-8 tube's lower rod end to C339-1 or -10 jackshaft weldment.

**CAUTION**

Do not remove tri-wing fastener; servo's lower rod end must remain attached to servo.

6. Disconnect D205 hose assemblies from servo unions (or elbows) and tees. Cap and plug fittings.
7.
  - a. Forward Servo: Remove hardware joining D200-2 scissors. Remove hardware securing servo to D201-1 or -5 support and remove servo. Remove associated C121-24 or -28 push-pull tube.
  - b. Aft Servo: Remove hardware securing servo to C345-5 weldment.

### 8.750 Hydraulic Servo Removal (continued)

8. Aft Servo: Measure & record center-to-center dimension between servo's lower rod end and C343-8 tube's lower rod end. Loosen palnut and nut securing tube to servo's lower rod end and remove tube.

**CAUTION**

Dimension between C343-8 tube's rod ends must be  $3.90 \pm 0.03$  inches. If dimension is not within required range, perform main rotor rigging per Section 10.120 after servo installation.

9. Remove clevis, scissor, D200-3 washer, elbows, unions, and tee fittings from servo, as applicable.
10. Actuate servo piston shaft by hand and drain as much hydraulic fluid from servo as possible. Plug servo ports.

### 8.760 Hydraulic Servo Installation

**CAUTION**

Do not pressurize hydraulic system while any hydraulic system component is disconnected or removed.

**CAUTION**

Refer to Section 8.750. Dimension between clevis hole center and top of servo piston shaft must be  $1.40 \pm 0.03$  inches; dimension between top of servo piston shaft and top of cylinder assembly must be  $0.28 \pm 0.03$  inch; dimension between C343-8 tube's rod ends must be  $3.90 \pm 0.03$  inches. If dimension(s) recorded during servo removal were not within required range, or if dimension(s) are unknown, adjust to correct dimensions in Section 8.760 steps 1 and 2, proceed with servo installation thru step 11, then perform main rotor rigging per Section 10.120.

1. Refer to Figures 8-1A and 8-1C. Lightly coat D200-1 clevis threads with B270-21 protectant. Assemble clevis, palnut, jam nut, D200-3 washer (forward servo), and D200-2 scissor (forward servo), and install assembly in D212-1 hydraulic servo assembly piston shaft. Point scissor forward and inboard. Adjust dimension between clevis hole center & top of servo piston shaft to dimension recorded during servo removal. Verify slots in scissor and washer engage piston shaft tangs, then tighten jam nut and palnut finger tight.
2. Aft Servo: Lightly coat servo's lower rod end threads with B270-21 protectant and install C343-8 tube. Adjust tube on servo's rod end, and tube's rod end, to the center-to-center dimension (between rod ends) recorded during servo removal, and with rod ends  $90^\circ$  to each other. Tighten jam nuts and palnuts finger tight.

**CAUTION**

Do not remove tri-wing fastener; servo's lower rod end must remain attached to servo.

8.760 Hydraulic Servo Installation (continued)

3. a. Forward Servo: Position associated C121-24 or -28 push-pull tube in helicopter. Install hardware securing servo to D201-1 or -5 support. Standard torque fasteners per Section 1.320 and torque stripe per Figure 2-1.  
b. Aft Servo: Install hardware securing servo to C345-5 weldment. Standard torque fasteners per Section 1.320 and torque stripe per Figure 2-1.
4. Forward Servos: Install hardware joining scissors (scissor overlap direction not critical); special torque nut to 25 in.-lb, special torque palnut to 5-10 in.-lb, and torque stripe per Figure 2-1.
5. Using backup wrench, align clevis minimum amount necessary to be parallel with helicopter's longitudinal axis. Standard torque jam nut and palnut per Section 1.320, and torque stripe per Figure 2-1.
6. Install hardware securing servo clevis to C121-25 or -31 push-pull tube's lower rod end. Standard torque fastener per Section 1.320 and torque stripe per Figure 2-1.
7. a. Forward Servo: Lightly coat servo's lower rod end threads with B270-21 protectant. Counting number of turns recorded during servo removal, install C121-24 or -28 push-pull tube on servo's lower rod end. Install hardware securing tube's lower rod end to C175-4 cyclic pivot assembly, standard torque fastener per Section 1.320, and torque stripe per Figure 2-1. Using backup wrench, standard torque tube's jam nuts and palnuts, and torque stripe per Figure 2-1.  
b. Aft Servo: Install hardware securing C343-8 tube's lower rod end to C339-1 or -10 jackshaft weldment. Standard torque fastener per Section 1.320 and torque stripe per Figure 2-1. Using backup wrench, standard torque jam nuts and palnuts, and torque stripe per Figure 2-1.
8. Refer to Figure 2-1A. Verify proper rod end centering on all push-pull tubes attached to servos.

**CAUTION**

Refer to Figure 8-16. Improper retainer installation can result in loss of hydraulic fluid and vibrations in the flight controls.

9. Remove caps and plugs. Lubricate new packings using A257-15 hydraulic fluid and install packings on servo unions (or elbows) and tees. Install fittings with associated hardware in servo ports and connect D205 hose assemblies to fittings. Align fittings to minimize hose preload and ensure hose clearance with surrounding structure; special torque fittings per Section 1.330 and torque stripe per Figure 2-1. Special torque hose B-nuts per Section 1.330 and torque stripe per Figure 2-1.
10. a. Forward Right Servo: Install aux fuel tank per Section 12.122.  
b. Forward Left Servo: Install main fuel tank per Section 12.112.
11. Bleed hydraulic system per Section 1.190.

8.760 Hydraulic Servo Installation (continued)

12. Perform the following measurements on all servos just installed:
  - a. Measure & record dimension between clevis hole center & top of servo piston shaft. Verify dimension is same as recorded during removal; adjust as required.
  - b. Apply cyclic and collective frictions. With collective full down and hydraulics unpressurized, manipulate cyclic stick so piston in servo just installed is in its lowest position. Measure & record dimension between top of servo piston shaft and top of cylinder assembly. Verify dimension between top of piston shaft and top of cylinder is same as recorded during removal. As required, lengthen or shorten associated C121-3, -24, -28, or -30 push-pull tube to obtain correct dimension and repeat this step.

**NOTE**

Cyclic must be manipulated after each push-pull tube adjustment and prior to measuring in order to accommodate freeplay at unpressurized input.

**CAUTION**

Dimension between clevis hole center and top of servo piston shaft must be  $1.40 \pm 0.03$  inches; dimension between top of servo piston shaft and top of cylinder assembly must be  $0.28 \pm 0.03$  inch; dimension between C343-8 tube's rod ends must be  $3.90 \pm 0.03$  inches. If dimension(s) recorded are not within required range, adjust to correct dimensions in Part 8.760 steps 1 and 2, proceed with servo installation thru step 11, then perform main rotor rigging per Section 10.120.

13. Install aft belly panel. Install C706-1 tailcone fairing assembly and mast fairing.
14. Perform pitot line leak check per Section 13.211.

Intentionally Blank