

CHAPTER 2
INSPECTION

<u>Section</u>	<u>Title</u>	<u>Page</u>
2.000	Introduction	2.1
2.100	General Procedures	2.1
2.110	Ball and Roller Bearings	2.1A
2.120	Push-Pull Tubes, Rod Ends, and Spherical Bearings	2.3
2.121	Push-Pull Tubes	2.3
2.122	Rod Ends and Spherical Bearings	2.3
2.125	Elastomeric Bearings	2.5
2.130	Telatemp Indicators	2.6
2.140	Torque Stripes	2.6
2.200	Ground and Flight Check For 100-Hour/Annual Inspection	2.7
2.205	Ground Check	2.7
2.210	Run Up	2.9
2.220	Flight Check	2.11
2.230	Shutdown	2.11
2.300	Airframe Preparation For 100-Hour/Annual Inspection	2.13
2.400	100-Hour/Annual Airframe Inspection	2.13
2.410	Inspection Procedures and Checklist	2.13
2.500	Special Inspections	2.39
2.501	Upper and Lower Clutch Actuator Bearings Inspection	2.39
2.502	C181 Lower Bearing Inspection	2.39
2.503	C184 Upper Bearing Inspection	2.40
2.507	V-Belt Inspection	2.41
2.508	Lower Sheave V-Belt Wear Pattern Inspection	2.43
2.510	Tail Skid Strike	2.45
2.520	Tail Rotor Strike	2.48
2.530	Main Rotor Strike	2.49
2.540	Rotor/Engine Overspeed	2.50
2.550	Hard Landing	2.51
2.560	[Reserved.]	2.54
2.561	Corrosion on C020 Upper Steel Tube Frame	2.54
2.570	Volcanic Ash Recommendations	2.55
2.580	Windshield Inspection	2.57
2.590	Lightning Strike	2.58
2.595	C148 Bulkhead Inspection	2.59

CHAPTER 2

INSPECTION (Continued)

<u>Section</u>	<u>Title</u>	<u>Page</u>
2.600	2200-Hour/2400-Hour/12-Year Inspection	2.60
2.610	Tail Rotor Gearbox 12-Year Maintenance	2.62
2.620	Fanwheel 12-Year Maintenance	2.63
2.630	C258-5 & -8 Main Rotor Pitch Link Assembly Inspection	2.64
2.640	Swashplate Assembly 12-Year Inspection	2.65
2.650	Landing Gear Assembly Inspection	2.66
2.660	Hydraulic Reservoir 12-Year Inspection	2.67

CHAPTER 2

INSPECTION

2.000 Introduction

The R44 helicopter must be inspected periodically to verify it is in airworthy condition; refer to Table 1. Required inspection intervals are maximum 100 hours time in service or 12 calendar months (annually), whichever occurs first; the inspection interval may be extended up to 10 hours, without accumulation, if allowed by local regulations.

NOTE

Helicopters on a Part 91 Approved Inspection Program (AIP), a Part 135 Approved Aircraft Inspection Program (AAIP), or an equivalent foreign-approved inspection program, must refer to & comply with that program. Refer to current revisions of FAA Advisory Circulars 91-90 & 135-10.

Fluid leaks, discoloration, dents, scratches, nicks, cracks, galling, chafing, fretting, and corrosion all warrant further investigation. Unairworthy items must be replaced or repaired as allowed by Robinson Helicopter Company. This section contains procedures for performing the required periodic airframe inspections.

NOTE

Unless directed by Service Bulletin, parts which were not listed as requiring replacement during previous compliance with a 12-year or 2200-hour/2400-hour Inspection may remain in service until next 12-year or 2200-hour/2400-hour Inspection (whichever occurs first).

2.100 General Procedures

Refer to U.S. FAA AC 43.13-1B Chapter 5 Section 2 for Visual Inspection guidance, and Chapter 11 Section 8 paragraph 11-97 for Wiring Replacement guidance. When required, magnetic particle inspection may be performed in accordance with ASTM E 1444 and MIL-STD-1907. Fluorescent penetrant inspection may be performed in accordance with ASTM E 1417 and MIL-STD-1907. For following components, use accompanying inspection criteria unless otherwise specified.

2.110 Ball and Roller Bearings

The first indication of bearing failure is usually an increase in bearing noise. Noise will almost always start several hours before bearing failure or any increase in bearing temperature. Listen to drive system during start-up and shutdown. A failing bearing will produce a loud whine, rumble, growl, or siren sound. Upon hearing an unusual noise, thoroughly inspect all bearings before further flight. A failing bearing may have a distorted seal or be exuding a large amount of grease. Do not rely on Telatemps to detect failing bearings as temperature increase may occur only seconds before bearing disintegrates. Refer to § 2.501.

The failure of either actuator bearing in flight could cause loss of power to the rotor system and could result in a serious accident. The actuator upper roller bearing is on the clutch shaft aft of the upper sheave; the actuator lower roller bearing is on the fanshaft aft of the lower sheave. Just before complete failure of an actuator bearing, the clutch light may flicker constantly (on and off in less than one second). This should not be confused with its normal on-off retensioning in flight (on for 1-8 seconds then off). Flight should not be resumed until cause of the flickering clutch light has been determined.

Intentionally Blank

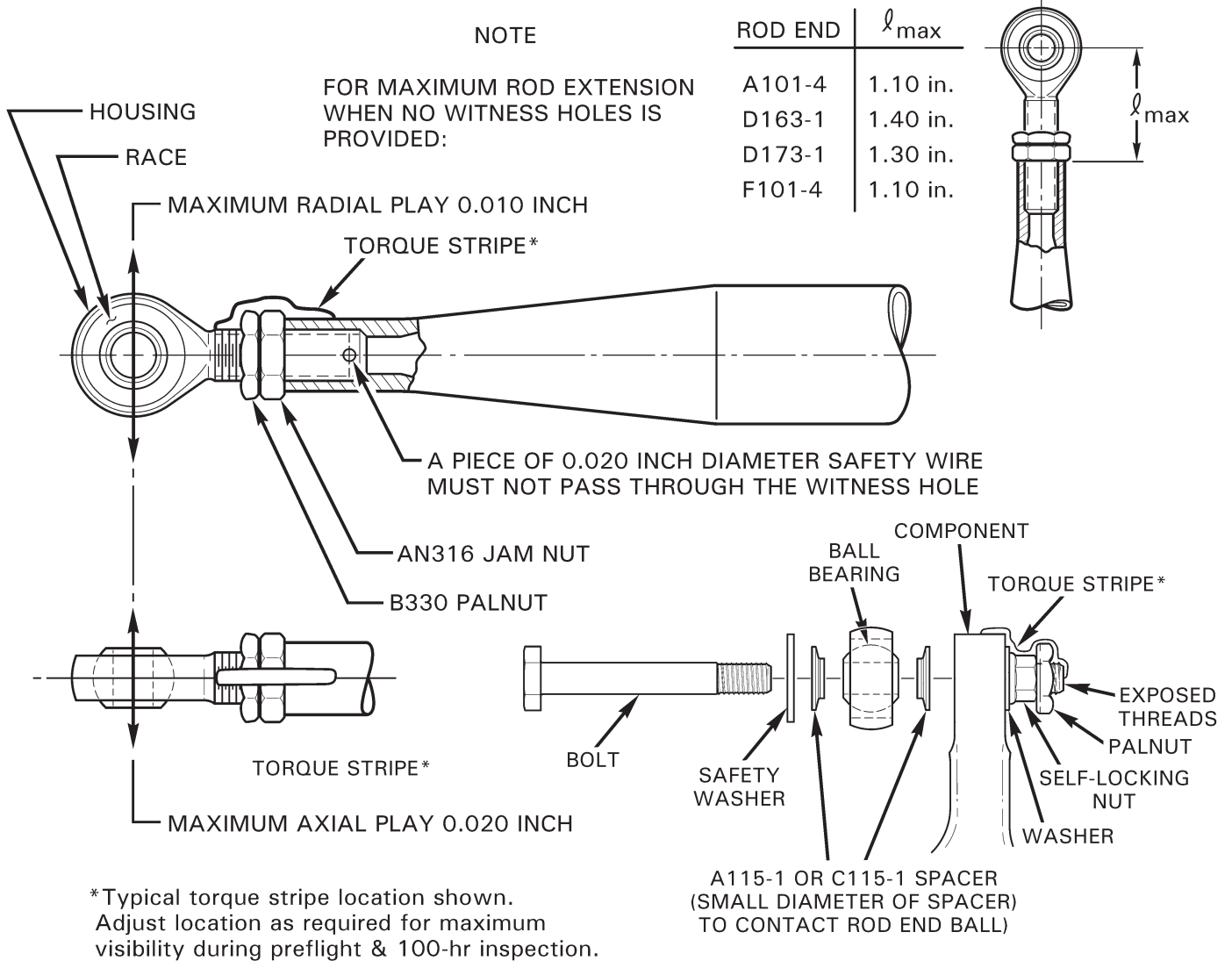

FIGURE 2-1 ROD END AND SPHERICAL BEARING PLAY LIMITS AND TORQUE STRIPE APPLICATION

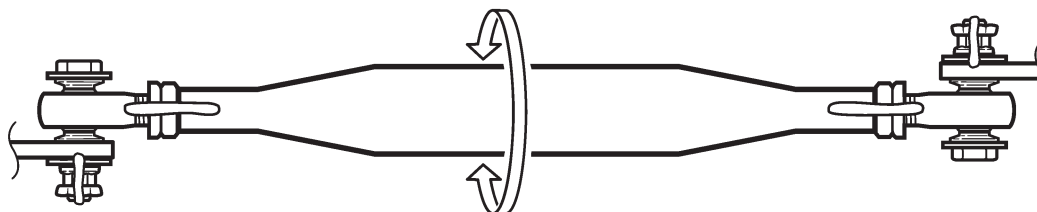

FIGURE 2-1A ROD END CENTERING
(Position rod ends for maximum rotation)

2.120 Push-Pull Tubes, Rod Ends, and Spherical Bearings

2.121 Push-Pull Tubes

1. Nicks, cuts, or scratches in tube not more than 0.010 inch deep and not more than 1/4 of tube circumference may be polished out in lengthwise direction using 320-grit or finer wet-or-dry abrasive paper to 1-inch minimum blend radius. Replace push-pull tube if depth exceeds these limits.
2. Replace push-pull tube if tube is dented or flattened more than 5% of its diameter in unswaged area; dents or flattening is not permitted in swaged (tapered and threaded) ends of tubes.
3. Replace any C121 push-pull tube if tube threaded end allows insertion of inspection pin beyond allowable limits per following table:

Thread Size	Example Rod End	Maximum Diameter Inspection Pin
10-32	A933-3	0.1730 inch diameter for first 0.09 inch of threads; 0.1670 inch diameter for remaining threads
1/4-28	A127-4	0.2300 inch diameter for first 0.11 inch of threads; 0.2240 inch diameter for remaining threads
5/16-24	A101-4	0.2880 inch diameter for first 0.13 inch of threads; 0.2820 inch diameter for remaining threads
3/8-24	D173-2	0.3520 inch diameter for first 0.15 inch of threads; 0.3440 inch diameter for remaining threads

2.122 Rod Ends and Spherical Bearings

1. Maximum axial play: 0.020 inch (for A104-4 bearing only: 0.035 inch axial play)
Maximum radial play: 0.010 inch
2. Looseness between spherical bearing outer race & rod end housing, or between spherical bearing outer race & part, is not permitted.
3. Rod ends not riveted in place must block passage of 0.020-inch diameter wire through witness hole. Refer to Figure 2-1 for maximum rod end extension when no witness hole is provided.
4. Rod end jam nuts and stamped nuts must be torqued per § 23-32 and torque striped per Figure 2-1 at the most visible position for pre-flight inspection. Torque stripe must extend across nuts to both rod end shank and push-pull tube (or pitch link barrel, yoke, support, strut, etc.). Torque stripes are subject to deterioration and must be periodically renewed.
5. Refer to Figure 2-1A. Rod ends must be positioned (centered) to allow as much push-pull tube or link rotational movement as possible without binding.

CAUTION

Teflon-lined bearings must not be lubricated or solvent cleaned.

WARNING

Assembly of flight controls is critical and requires inspection by a qualified person. If a second person is not available, RHC recommends the installer take a 5-minute break prior to inspecting flight control connections the installer has assembled.

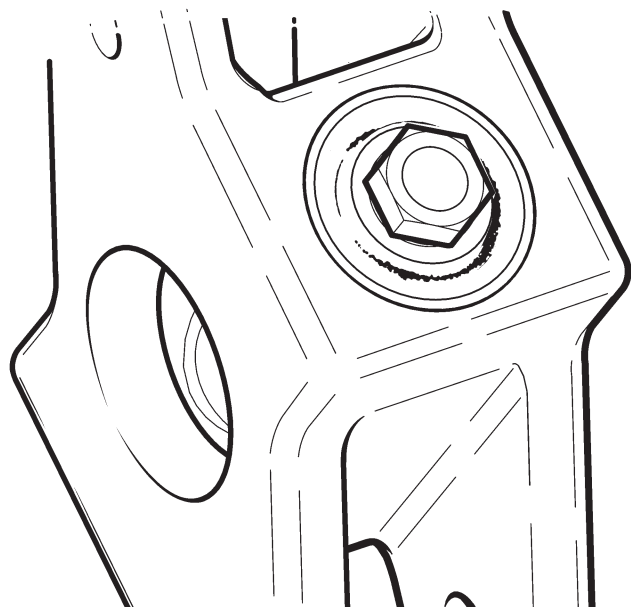

FIGURE 2-2A
ELASTOMER FATIGUE

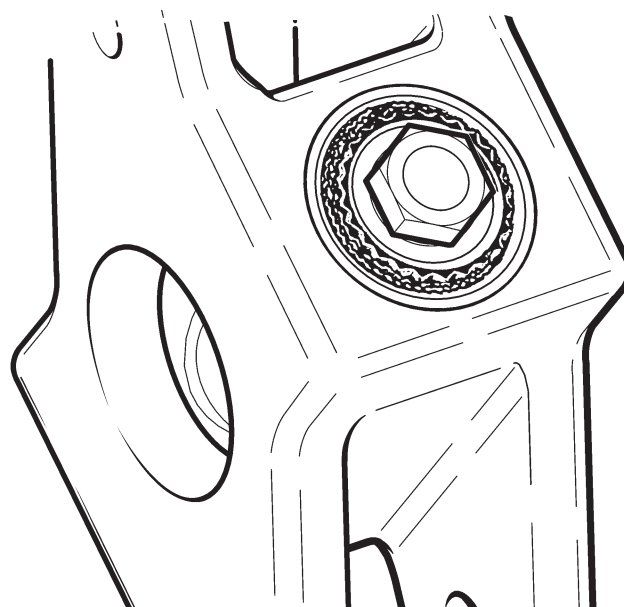

FIGURE 2-2B
ELASTOMER OIL CONTAMINATION

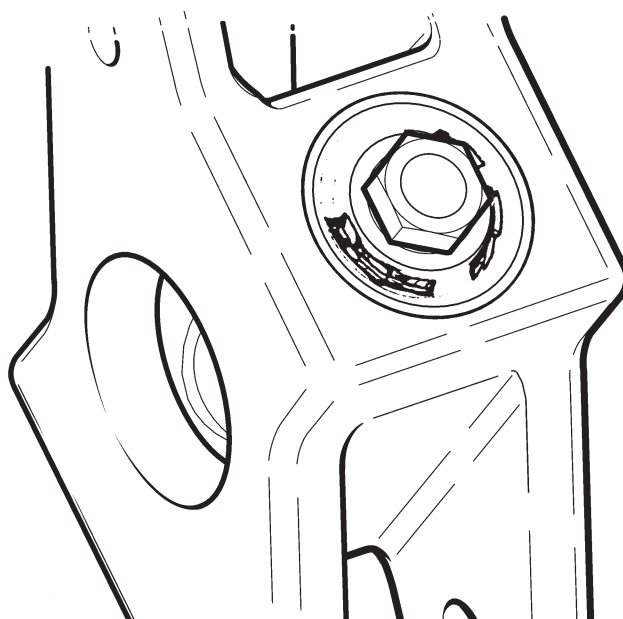

FIGURE 2-2C
ELASTOMER OVERLOAD

2.125 Elastomeric Bearings

Elastomeric bearings are used in the D062-1 tail rotor hub assembly. Fatigue, oil contamination, or overload can degrade the elastomer.

Small surface cracks (fatigue cracks) and elastomer dust or “eraser crumbs” (see Figure 2-2A) are normal and are not cause for replacement. As cracks grow, enough elastomer will be lost to cause reduced stiffness and increased vibration. If deep (greater than 0.10 inch) cracks are present over more than 25% of elastomer face, replace bearing.

Avoid exposure to oil, grease, hydraulic fluid, cleaning solvent, and rust-preventative fluids. Immediately wash off any such contaminants with detergent and water. Contaminated bearings exhibit swelling, wavy edges, or debonding (see Figure 2-2B) and must be replaced.

Overload occurs when elastomer’s tensile strength or rubber-to-metal bond strength is exceeded. This can occur when normal loads are applied to a bearing weakened by fatigue or oil contamination. Overload is indicated by large extrusions from and large clean cracks in elastomer as shown in Figure 2-2C.

Elastomer may also separate (debond) from metal bushings. If separation occurs over more than 25% of bonded area, replace bearing.

2.130 Telatemp Indicators

Refer to Figure 2-3. Self-adhesive Telatemp indicators record changes in operating temperatures of bearings and gearboxes. To use a Telatemp, draw a reference line between the highest temperature square which has darkened during normal operation and the next undarkened square. During every check thereafter, determine if an additional square has blackened. If an indicated temperature increase cannot be accounted for by a change in operating conditions, carefully examine the component before further flight.

NOTE

Telatemp can indicate erroneously if contaminated by a petroleum product, typically appearing as white, unactivated square(s) between darkened squares at each end; replace any Telatemp indicating as such and clean area with acetone prior to installing.

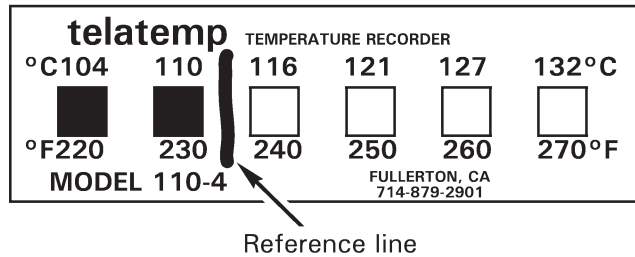

FIGURE 2-3 TELATEMP INDICATOR WITH DRAWN REFERENCE LINE

Part Number	Temperature Range
F110-2	60°C / 140°F — 88°C / 190°F
F110-3	82°C / 180°F — 110°C / 230°F
F110-4	104°C / 220°F — 132°C / 270°F

2.140 Torque Stripes

If, during inspection, the remaining torque stripe on a fastener is insufficient to determine joint integrity, then remove accompanying palnut as required and apply specified torque to fastener. If fastener moves, disassemble joint and inspect parts for damage such as fretting, thread deformation, hole elongation, etc.; replace damaged parts. If fastener does not move, install new palnut as required & standard torque per § 1.320. Torque stripe fastener per Figure 2-1.

2.200 GROUND AND FLIGHT CHECK FOR 100-HOUR/ANNUAL INSPECTION

Complete following checklists in conjunction with a 100-hour or annual inspection. Note and correct any discrepancies.

2.205 Ground Check (Aircraft not running)

- 1. **Throttle Control:** Check for freedom of rotation with collective full down and full up. _____
- 2. **Throttle Overtravel Spring:** Check by twisting throttle past idle position to override stop. Release throttle and ensure it returns to normal idle position. _____
- 3. **Mixture Control:** Check for smoothness of operation with no binding. Check press-to-unlock button for proper function. Verify 0.03 to 0.10 inch spring-back at full rich position. _____
- 4. **Carburetor Heat Control (O-540 only):** Check for smoothness of operation with no binding. Verify 0.03 to 0.10 inch spring-back at full off position. _____
- 5. **Cyclic Control:** With trim motors (if installed) in neutral position, verify freedom thru full travel with friction off. Verify friction knob rotates 1/8-to-1 full turn before adding friction. For hydraulic controls: Verify approximately one-half inch total longitudinal and one inch total lateral freeplay before encountering resistance. Verify normal hydraulic resistance with no binding or abnormal feel throughout control travel. _____
- 6. **Collective Control:** Verify freedom through full travel with friction off and on. For non-hydraulic aircraft, verify friction knob moves 0.3-0.6 inch before adding friction. For hydraulic controls: Verify approximately one-half inch total freeplay before encountering resistance. With carb heat assist (if installed) locked and friction lever fully off, verify C334 friction (between rear seats) within freeplay range is 4-5 pounds average measured at grip. With friction lever fully on, verify 18-22 pounds measured at grip. Verify normal hydraulic resistance with no binding or abnormal feel throughout control travel. _____
- 7. **Carb Heat Assist (if installed):** With collective down and full carb heat, raise collective full up and verify carb heat off. Lower collective full down and verify carb heat full on. With collective friction off, push carb heat off and verify collective stays down. _____
- 8. **Tail Rotor Pedals:** Check for smooth operation with no binding. _____
- 9. **Removable Controls:** Verify security of attach fasteners. _____

2.205 Ground Check (cont'd)

10. Lighting and Instruments: (Master Switch on)

- a. CARBON MONOXIDE warning light flashes twice (if installed). _____
- b. Carb Air Temp approximately same as Outside Air Temp. _____
- c. ALT warning light on. _____
- d. OIL pressure warning light on. _____
- e. AUX FUEL PUMP warning light on (IO-540 only). _____
- f. Fuel quantity gages - indication of fuel level. _____
- g. Navigation and panel lights - check function. _____
- h. Strobe light - check function. _____
- i. Landing lights - check function (clutch switch must be engaged to check landing lights). _____
- j. Map light - check function. _____
- k. Ammeter - shows discharge. _____
- l. Oil temperature gage - slight needle deflection with engine cold. _____
- m. Cylinder head temp gage - slight needle deflection with engine cold. _____
- n. MR TEMP light - on when sender shorted or test switch depressed. _____
- o. MR CHIP light - on when sender shorted or test switch depressed. _____
- p. ENGINE FIRE light – on when sender shorted or test switch depressed. _____
- q. TR CHIP light - on when sender shorted or test switch depressed. _____
- r. LOW FUEL light - on (slight delay is normal) when low fuel sender in tank is depressed with clean, non-sparking rod or when test switch depressed. _____
- s. FUEL FILTER light – on when test switch depressed (IO-540 only). _____

11. Verify aircraft checklist laminated card is current revision (refer to Section 1.002). _____

2.210 Run Up

- 1. Perform POH Section 4 "Preflight" checklist. _____
- 2. Perform "Before Starting Engine" checklist. _____
- 3. IO-540 engine: Verify AUX FUEL PUMP light extinguishes during prime and illuminates after priming. Verify fuel drains from sniffle valve. _____

NOTE

Significant prime may be required before fuel drains from sniffle valve. Wait for valve to stop draining before starting engine. Engine will be hard starting/flooded while valve is draining.

- 4. Perform "Starting Engine and Run-Up" checklist. If less than 15 minutes has elapsed since Step 3, use minimum or no prime. _____
- 5. With alternator switch ON, verify ammeter shows positive charging indication and ALT light off. _____
- 6. Check clutch engagement time – maximum 80 seconds. _____
- 7. Both magnetos ground (off momentarily) at 60% RPM. _____
- 8. Verify ALT light illuminates within 10 seconds after alternator is switched OFF. Verify tachometer operates with alternator and battery switches off. Turn battery & alternator switches on. _____
- 9. No unusual bearing noise when varying RPM through operating range (mechanic to listen near V-belt drive). Refer to §§ 2.110 and 2.501 thru 2.503. _____
- 10. Set RPM at 75%, governor on. Increase to 85%, release throttle, and verify governor increases RPM to 101 to 102%. Increase RPM to 104%, release throttle, and verify governor decreases RPM to 101 to 102%. _____
- 11. Engine and rotor tach needles within 1% of each other at 102% RPM. _____
- 12. Verify alternator voltage as follows: _____
 - 13.4 to 13.9 vdc for 14-volt A942-3 alternator control unit
 - 27.75 to 29.25 vdc for 28-volt A942-4 alternator control unit
- 13. Heater operates properly. _____
- 14. Tachometer needles do not jump more than 2% when transmitting on 118.00, 125.00, and 136.975 MHz with governor on. _____
- 15. Raise collective control 0.5 inch at grip and slowly decrease RPM. Verify low-rotor-RPM warning horn and light activate at 97% to 96% RPM and remain on as RPM is decreased to idle. _____

2.210 Run Up (continued)

- 16. Idle RPM with engine warm, clutch engaged, throttle closed –
 - O-540 engine: 53% – 57% _____
 - IO-540 engine: 58% – 62% _____
- 17. Idle mixture with engine warm, clutch engaged, throttle closed. _____
 - O-540 engine: 2% to 4% RPM rise as mixture is pulled slowly to idle cut-off. Adjust idle mixture screw as required. If unable to obtain rise, set idle mixture screw 1 ½ turns out from fully in then adjust as required for smooth idle. _____
 - IO-540 engine: Adjust idle mixture per § 6.495, Step 23. _____
- 18. Check hydraulic system operation. Move cyclic-mounted hydraulics switch to OFF. Using small longitudinal cyclic inputs, there should be approximately one-half inch of freeplay before encountering stiffness and feedback. Turn hydraulics ON. Controls should be free with no feedback or uncommanded motion (“motoring”). Complete flight check with hydraulics on. _____
- 19. Air Conditioning: Verify system blows cold air on both low and high settings. Verify no EMI/RFI with other instruments and systems. After a flight with air conditioning on, verify water drains from drain tube in ship’s belly (may be little or no water in very dry conditions). _____

2.220 Flight Check

1. Hover:

- a. All gages green. _____
- b. Controllability in left and right pedal turns. _____
- c. Hydraulics zero cyclic stick forces. _____ |
- d. Vibration levels satisfactory. _____

2. Level Flight: Typical cruise altitude (if possible, deviate as required for weather and regulations), maximum continuous power, governor on.

- a. Vibration levels satisfactory. _____
- b. Hydraulics zero cyclic stick forces. _____ |
- c. Verify no feedback and collective is balanced. _____
- d. Tail rotor pedal position when yaw string is centered: 0.25 to 0.75 inch right for adjustable pedals, within 0.25 inch of neutral for non-adjustable pedals. _____
- e. Tail rotor elastic trim cord zeros pedal forces (cord applies left pedal force). _____
- f. Turn hydraulics OFF and verify no excessive feedback forces. _____ |

2.230 Shutdown

- 1. Verify rotor brake functions and ROTOR BRAKE light illuminates. _____
- 2. Complete shutdown per POH checklist. _____

Intentionally Blank

2.300 Airframe Preparation for 100-Hour/Annual Inspection

The helicopter must be thoroughly cleaned prior to inspection in accordance with U.S. 14 CFR Part 43, Appendix D, Paragraph (a). If needed, use a mild soap (pH between 7 & 9) and water solution per Chapter 23.

CAUTION

During pre-inspection cleaning, prior to removing any residue, note and identify both residue & source for follow-up examination. Residue may be fuel, oil, grease, paint, plastic, magnetic-metal, non-magnetic-metal, etc, including combinations; metal residue may indicate structural damage and requires careful attention. Residue may be visible on adjacent structure and not on the source part itself.

CAUTION

Do not spray magnetos, main rotor hub, tail rotor gearbox vent, hydraulic reservoir vent, swashplate area, or bearing seals with high-pressure water or solvent as water or solvent may enter and cause corrosion and breakdown of lubricants.

2.400 100-Hour/Annual Airframe Inspection

CAUTION

If pop-out floats are installed, ensure safety on pilot’s red inflation lever is in LOCKED position when working on helicopter.

WARNING

Pop-out float pressure cylinder contents are under extreme pressure. If pop-out floats are installed, install locking pin in pressure cylinder valve (see Figure 5-6) when working in forward left baggage compartment, during cylinder removal or installation, and when working on floats or inflation hoses. Remove locking pin when work is completed. Avoid excessive heat (> 200 degrees F) as thermal relief valve will activate.

Perform 100 hour or annual airframe inspections per § 2.410. RHC recommends keeping a copy of the most recently performed checklist with the aircraft’s maintenance records.

2.410 Inspection Procedures and Checklist

R44 Serial No.: _____	Technician name: _____
Registration No.: _____	Technician _____
Hourmeter Indication: _____	Certificate number: _____
Aircraft Total Time: _____	

Numbers in parentheses indicate access location per Figures 2-4 and 2-4A.

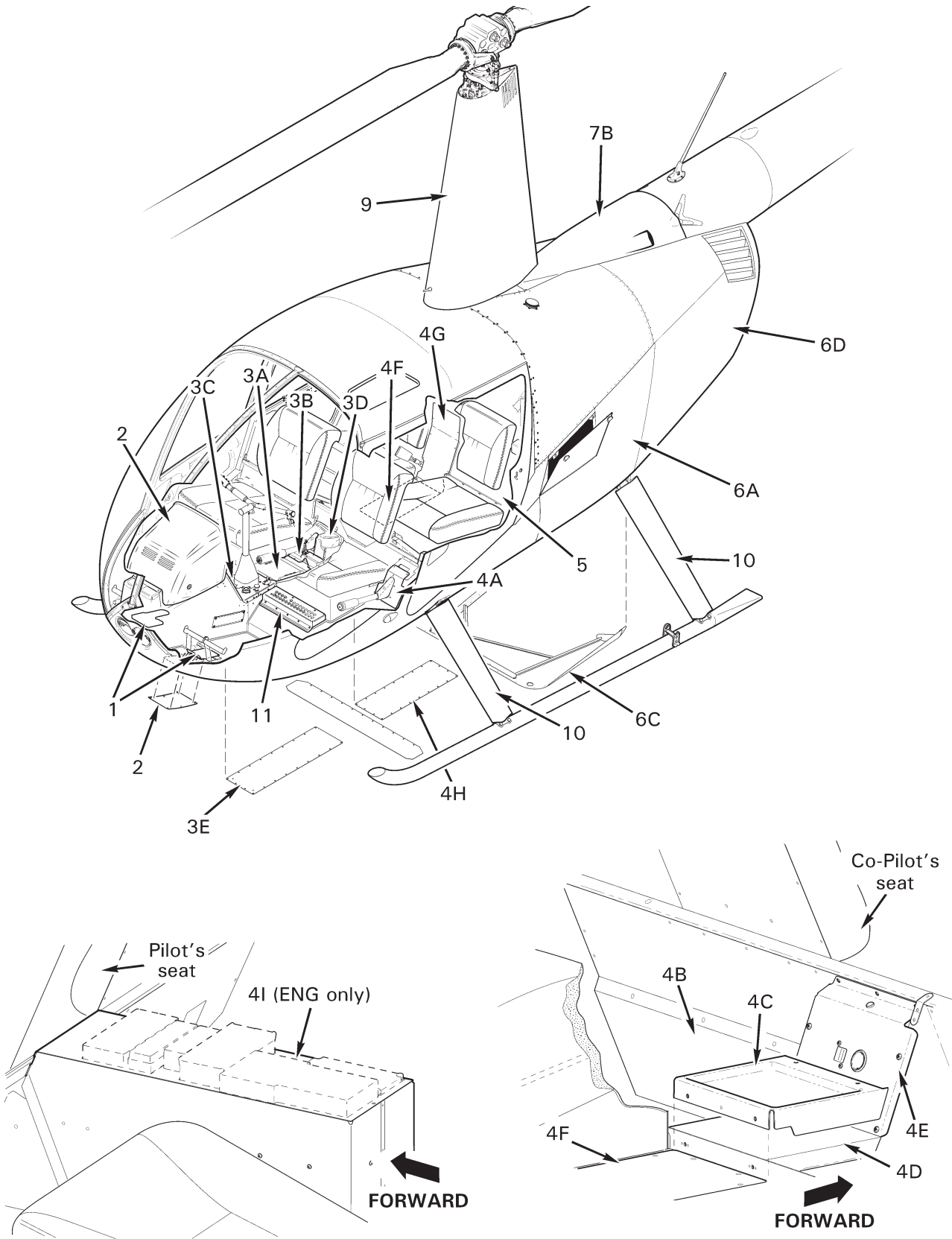

FIGURE 2-4 ACCESS AND INSPECTION PANELS

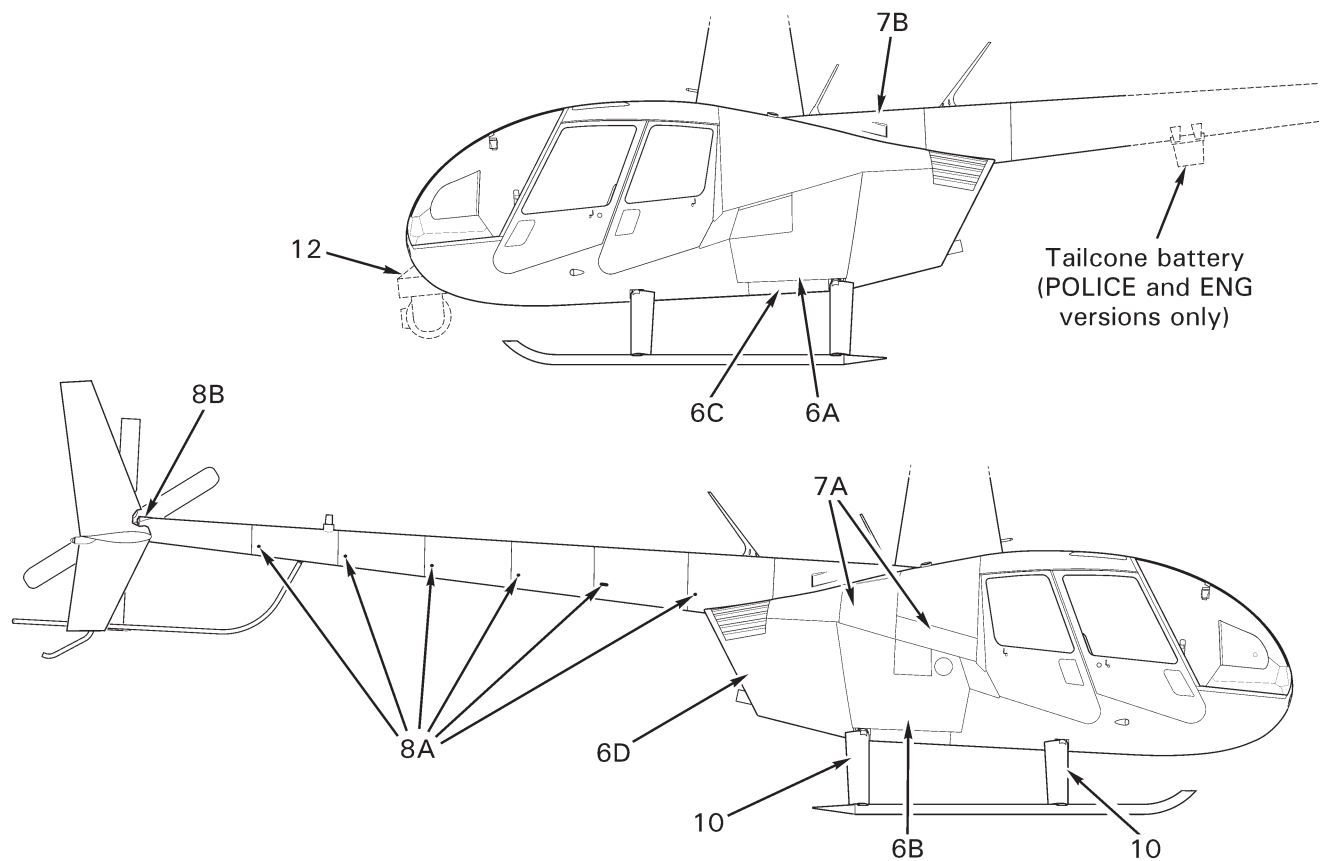

FIGURE 2-4A ACCESS AND INSPECTION PANELS

2.410 Inspection Procedures and Checklist (continued)

1. Tail Rotor Pedal Bearing Blocks

NOTE

Do not remove pedal bearing block cover plates (1) unless function check of pedals indicates possible problem with pedal bearing blocks.

To remove cover plates (1) peel back carpeting and remove screws holding plates. Use an inspection light and mirror to inspect bearing blocks. Inspect for condition and looseness or play. Maximum allowable play is 0.080 inch axially and 0.030 inch radially. Inspect all weld areas in pedal controls.

2.410 Inspection Procedures and Checklist (continued)

2. Remove chin inspection cover, & remove or open upper console assembly per § 13-80:

<p>CAUTION</p> <p>Instrument console removal (§ 13-80) is not required for scheduled inspections. Sufficient access for inspection is gained by removing the chin inspection cover, as well as removal of installed avionics, as required (refer to Chapter 38).</p>

Upper Console Assembly: Inspect condition. Verify hinge security.

Pitot-Static System: Check pitot and static lines for cracking, chafing, pinching or kinking. Check all connections for security. _____

Flight and Engine Gages: Check all gauges for security. Inspect wiring and connections on all gages. _____

Radio Tray(s): Check condition and security. _____

Tail Rotor Controls: Check accessible portions of TR pedal assemblies for defects. Verify operating clearance. _____

3. Remove Forward Tunnel Covers (3A & 3B), Cyclic Stop Cover (3C), Inboard Collective Cover (3D), and Forward Belly Panel (3E) _____

<p>NOTE</p> <p>If radio antennas are installed on removed panels, disconnect antenna lead and any ground wire. Pull respective radio circuit breaker and tag circuit breaker with "Antenna Removed".</p>

Cyclic Box Assembly: Inspect cyclic box assembly for defects. Check cyclic stop sheet metal assembly for cracks and other defects (deterioration, distortion, loose rivets, corrosion). _____

Cyclic Stick Assembly: Inspect cyclic stick assembly for defects. Inspect welds for cracks. _____

2.410 Inspection Procedures and Checklist (continued)

3. Remove Forward Tunnel Covers (3A & 3B), Cyclic Stop Cover (3C), Inboard Collective Cover (3D) and Forward Belly Panel (3E) (continued)

Cyclic Friction: Check for excessive play or looseness in links and rod ends connected to cyclic stick. Verify no excessive flaring at either end of C130-2 spacer. _____

Cyclic Push-Pull Tube and Torque Tube: Inspect C319 torque tube paying special attention to area around blocks and end of torque tube for cracks. Inspect C121-1 push-pull tube rod end palnut and jam nut for tightness. Check witness holes on push-pull tubes. Check rod ends and bearings for excessive play and looseness. Check accessible portions of cyclic push-pull tube and torque tube for defects, including scratches. Pay particular attention to top of torque tube immediately below C348-1 anchor assembly. Inspect all nuts and bolts in cyclic controls for rotation and looseness. Verify operating clearance. _____

Tail Rotor Push-Pull Tube: Inspect accessible portions of C121-9 tail rotor push-pull tube. Check rod ends for excessive play and looseness. Verify operating clearance. _____

Collective Friction and Stop: Inspect collective stop condition; no nicks, cuts or scratches are allowed. Check collective friction lever for security and operation. Move collective up and down and verify no bending or binding of stop. Verify collective boot’s lace cannot entangle stop. _____

Throttle Overtravel Spring: Inspect operation of overtravel spring while operating throttle. It should move freely without any binding or jerkiness. Check play in upper and lower rod ends. Check rod ends for binding. _____

HeliSAS Autopilot (if installed): Inspect condition of associated equipment. Inspect wiring condition. Verify neatness, operating clearance, and security. _____

Wiring Harness: Inspect condition. _____

Pitot and Static Lines: Inspect pitot and static lines for security and any evidence of cracking, chafing, pinching or kinking from sharp bends. Open drains and check for moisture; close drains. _____

Elastic Trim Cords – Cyclic: With cyclic forward-right, feel forward elastic trim cords for voids which may indicate broken strands. _____

Heater Hose: Check heater hose for collapsed areas and chafing. _____

Fasteners and Torque Stripes: Inspect condition and verify security of all fasteners. Renew deteriorated torque stripes per Figure 2-1. _____

2.410 Inspection Procedures and Checklist (continued)

4. Remove Outboard Collective Cover (4A), Collective Torque Tube Cover (4B), Tray (4C), Mid Tunnel Covers (4D & 4E), Aft Tunnel Covers (4F & 4G), Aft Belly Cover Panel (4H), and Rear Console (4I, ENG ships only) (continued)

<p>NOTE</p> <p>If radio antenna is installed on removed panel, disconnect antenna lead and corresponding ground wire. Pull respective radio circuit breaker and tag circuit breaker with "antenna removed".</p>
--

Collective Stick: Inspect condition of collective stick. Inspect all welds for cracks. Inspect C328-1 connecting rod assembly giving special attention to points of attachment. Inspect governor motor and governor motor arm for looseness or binding. Inspect collective-activated micro switch for cracks or loose wires. Verify operating clearance of collective and throttle governor, to include no evidence of rubbing on inside of removed cover. _____

Collective Stick Torque Tube: Verify no corrosion pitting. Apply a corrosion-preventative compound such as LPS 2, ACF-50, or Corrosion-X to any unpainted, phosphate-coated area while avoiding contaminating governor friction clutch (a foam-type applicator works well). Ensure interior of open-end "box" structures at inboard attach point and at A205 fork connection are also treated. _____

Aft End of Cyclic Torque Tube and Yoke Assembly: Inspect torque tube and yoke, paying special attention to area around blocks and end of torque tube for cracks. Check play in bellcrank bearings per § 2.122. Inspect swaged bearing for movement in yoke. _____

Aft End of Cyclic Horizontal Push-Pull Tube (C121-1) and Lower Ends of Vertical Push-Pull Tubes: Inspect push-pull tubes for cracks. Check rod end jam nuts and palnuts for tightness and rod ends for play. Check rod end bearings for looseness. Inspect fork assembly areas. Check bearings for looseness. Check between bearings and swage for evidence of fretting. _____

Aft End of (C121-9) Tail Rotor Push-Pull Tube and Lower Bearing: Check witness hole. Check lower bellcrank bearing for play. Inspect all welds on support assembly for lower bellcrank and inspect surrounding sheet metal area for cracks. _____

Elastic Trim Cord – Tail Rotor: Feel elastic trim cord for voids which may indicate broken strands. _____

Collective Push-Pull Tube (C121-19): Check for binding or nicks. Check witness holes. Check jam nuts and palnut for tightness and rod end for play. _____

2.410 Inspection Procedures and Checklist (continued)**4. Remove Outboard Collective Cover (4A), Collective Torque Tube Cover (4B), Tray (4C), Mid Tunnel Covers (4D & 4E), Aft Tunnel Covers (4F & 4G), Aft Belly Cover Panel (4H), and Rear Console (4I, ENG ships only) (continued)**

Elastic Trim Cord – Collective: Feel elastic trim cord for voids which may indicate broken strands. _____

Collective Friction Assembly: Check jam nuts and palnuts for tightness and rod ends for play. Inspect all welds on bellcrank support assembly and inspect surrounding sheet metal for cracks and corrosion. _____

Throttle Control Linkage: Remove throttle control arm cover if cover is not transparent (under aft left seat [O-540], or inside tunnel [IO-540], at firewall). Inspect condition. Verify throttle control clearance to installed equipment and adjacent structure. Verify proper installation and security. Install cover. _____

Fuel Valve and Fuel Line: Inspect fuel line for damage and valve fittings for leakage (leakage is indicated by a blue or green residue, depending on fuel used, or odor of fuel). Verify no chafing of fuel lines. _____

Fuel Valve-to-Knob Torque Tube: Inspect condition. Verify attaching security. _____

Intentionally Blank

2.410 Inspection Procedures and Checklist (continued)

5. Remove Aft Seat Back Assemblies (5)

Wiring: Verify security, proper installation, and no deterioration. _____ |

Pitot and Static Lines: Check for security, chafing, and kinks. _____

Air Conditioning Refrigerant Lines (if installed): Verify security & no damage. _____

Evaporator Drain Tubes and Valve (if installed): Verify tubes are unobstructed. Place a container under sediment-tube protruding from bottom of tee-fitting into right-aft baggage compartment. Remove plug from sediment tube and allow any accumulated moisture and debris to drain. Reinstall plug. Simultaneously squeeze drain tube and sediment tube near tee-fitting and verify check-valve ball moves up momentarily. _____

Strobe Power Supply & Alternator Control Unit: Verify security. Inspect wiring. Inspect mounting panels for cracks. _____ |

Blind Encoder & Governor Controller: Verify security. Inspect wiring. Inspect mounting panels for cracks. _____ |

Fasteners and Torque Stripes: Inspect condition and verify security of all fasteners. Renew deteriorated torque stripes per Figure 2-1. _____

6. Remove Engine Aft (6D), Belly (6C), and both side (6A & 6B) Cowlings

Vertical Firewall: Inspect vertical firewall condition, especially around structural attachment points, verify no cracks, buckling or wrinkles. _____

Fuse(s) and Fuse Holder(s) (if installed on vertical firewall): Verify security and no corrosion. Verify correct fuses: -66 wire requires AGC-3 fuse, -1601/-1602 wires require AGC-5 fuse. If installed, -1226 wire requires AGC-3 fuse. _____

Wiring: Verify security, proper installation, and no deterioration. _____

Electric Fuel Pump (IO-540 only): Verify security, proper installation, unobstructed drain tube, and no leakage. _____

Fuel Line & Hose(s): Inspect condition. Verify security, proper installation, no leakage, & (IO-540 only) good condition of spirap insulation on fuel line between firewall & gascolator. If deteriorated, replace MS3367-5-9 ty-raps securing fuel hoses to clamps (reference R44 SB-67). _____

Lower Steel Tube Frames: Thoroughly inspect lower steel tube structure for corrosion and inspect all welds for cracks. Ensure frames are not chafed by wires, hoses, clamps, etc. _____

Engine Cooling Panels: Inspect cooling panels for cracks and missing fasteners. _____

Oil Cooler(s): Inspect oil cooler(s) and fittings for damage, leaks, cleanliness, and security. Check oil cooler mounting area(s) for cracks. _____

2.410 Inspection Procedures and Checklist (continued)

6. Remove Engine Aft (6D), Belly (6C), and both side (6A & 6B) Cowlings (continued)

Oil Lines: Inspect entire length of all oil lines and verify no cracks, abrasion, or broken clamps. Verify clearance; wires, ty-raps, and structure must not contact lines. _____

Gascolator: With fuel valve off, remove and clean gascolator bowl and filter screen. Verify no deterioration of gasket. If gascolator bowl is secured by threaded collar and ring, lightly lube threads and ring with A257-6 grease. Reassemble and turn fuel valve on. Safety wire after ensuring no leaks occur. Verify drain valve is secure and torque-stripped. _____

Mixture Control: Verify mixture control moves mixture control arm stop to stop. Inspect condition and verify security of mixture control cable clamps on bracket; push and pull cable housing to ensure it does not slip in clamps. Inspect condition and verify security of mixture control cable inner wire attachment to mixture control arm. Ensure freedom of rotation between mixture control arm and inner wire retention fitting (bolt) when arm moves. Verify mixture control safety spring is properly installed (so spring force holds mixture control arm at full-rich position if inner wire breaks). _____

Throttle Correlation Rigging: Check per § 10.150 and adjust as required. _____

Full-Throttle Switch Rigging: Check per § 37-70 and adjust as required. _____

Throttle Control Linkage: Inspect condition. Verify throttle control operating clearance to installed equipment and adjacent structure. Verify proper installation and security. _____

Air Box & Alternate Air Door: Ensure carburetor heat slider valve (if applicable) moves fully from stop to stop. Replace air filter (lubricating IO-540 air filter rubber with A257-8 rubber lubricant will facilitate sealing). Check air box for condition and security. Verify spring-loaded alternate air door opens without binding and closes completely. _____

Engine Air Inlet Hose: Verify no rips, holes, or collapsed areas. Remove hose from fuel-injected R44 II. Visually inspect inside of hose to verify no separation between outer and inner layers. Also, flex the hose in all directions and listen for a crinkling sound, which is an indication of separation. (An airworthy hose does not make a crinkling sound when flexed.) Replace any hose with any indication of separation. Install hose on fuel-injected R44 II. Verify correct installation & security. Ensure hose is not chafing frame. _____

Carburetor Heat Scoop and Hose (O-540 engines only): Inspect for condition and security. _____

Heater Hose: Inspect for condition and security. _____

2.410 Inspection Procedures and Checklist (continued)

6. Remove Engine Aft (6D), Belly (6C), and both side (6A & 6B) Cowlings (continued)

Aft Engine Mount: Inspect all welds for cracks. Verify no corrosion. Verify no contact between rod ends and C020 upper frame tabs per Figure 6-2. _____

Lead-Acid Battery Installations (under left front seat, left-side engine compartment, or mounted to tailcone): Refer to § 37-11. Inspect condition. Verify no cracks or corrosion on or near battery terminals. As required, perform capacity test per manufacturer’s instructions or replace battery. Verify battery cable security. Verify no corrosion in surrounding structure. _____

Lithium-Ion Battery Installation (if equipped; under left front seat or left-side engine compartment): Refer to § 37-12. Inspect condition. Verify no cracks or corrosion on or near battery terminals. Verify vent hose, comm connector wiring, and battery cable security. Perform scheduled maintenance as required. Verify no corrosion in surrounding structure. _____

7. Open Cowling Doors (7A), Remove Tailcone Cowling (7B) & Mast Fairing (9)

Cowling Door: Inspect hinges and latches for condition and security. _____

Tailcone cowling: Verify no cracks, air inlet obstructions, or loose rivets. _____

Electrical and Antenna Wires: Inspect condition. Verify security and no chafing, kinks or tight bends. _____

Emergency Locator Transmitter (ELT; if installed): In accordance with local regulation, test per ELT manufacturer instructions. If 406 Mhz ELT, confirm programming tag matches helicopter registration. If RHC installation, inspect condition of both primary hook & loop strap and secondary buckle strap or ty-rap; replace strap(s) if damaged or deteriorated. Verify ELT security and clearance to drive train. _____

MRGB Input Yoke: Inspect condition. Verify security and operating clearance. Verify security of magnets. _____

Intentionally Blank

2.410 Inspection Procedures and Checklist (cont'd)

7. Open Cowling Doors (7A), Remove Tailcone Cowling (7B) & Mast Fairing (9)
(cont'd)

Forward Flex Plate: Inspect condition, particularly edges. Verify security. Verify bonded washers are securely bonded to both sides of each flex plate arm. Verify operating clearance.

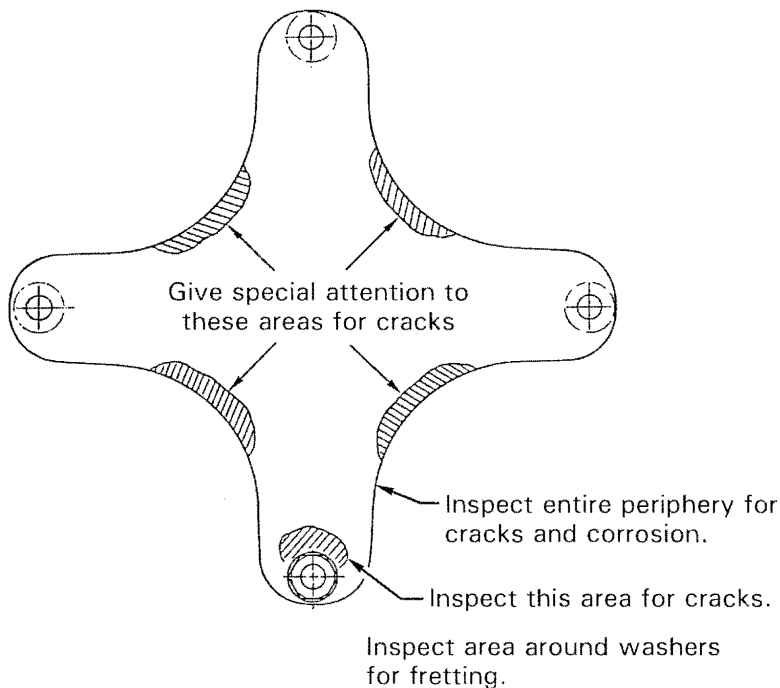

FIGURE 2-5 FLEX PLATE INSPECTION

Clutch Shaft Forward Yoke: Inspect condition. Verify no cracks, corrosion, or fretting. Verify security and operating clearance.

Rotor Brake: Inspect condition, including activating cable & pulleys and microswitch. Verify integrity of brake pads and 0.030 inch minimum pad thickness. Verify brake pad clearance to input yoke when brake is off. Verify security and operating clearance.

Jackshaft: Inspect entire welded assembly for cracks and corrosion. Inspect jackshaft supporting strut and tube weldments for security, cracks and corrosion.

Main Rotor Push-Pull Tubes: Inspect condition of viewable portions. Verify no cracks at ends. Inspect rod ends per Section 2.120. Verify no tears in sleeves (manual controls only). Verify security and operating clearances.

Main Rotor Push-Pull Tube Rollers & Bushings: (manual controls only): Inspect condition. Verify cleanliness, no wear into metal, and free movement of rollers.

2.410 Inspection Procedures and Checklist (cont'd)

7. Open Cowling Doors (7A), Remove Tailcone Cowling (7B) & Mast Fairing (9)
(cont'd)

Tail Rotor Push-Pull Tube and Upper Bellcrank: Inspect C121-15 push-pull tube, especially at ends, for cracks. Check jam nut for tightness and rod end for looseness. Inspect bellcrank and mounting for cracks or other defects.

Main Rotor Gearbox Cooling Hoses: Inspect both ends for security. Inspect for rips, holes, and chafing.

Main Rotor Gearbox: Inspect main rotor gearbox, especially around gearbox mounts, cap mounting lugs, and mast tube for cracks. Verify no contamination and no deterioration of rubber mounts. Verify security of Hall Effect senders. Check Telatemp for overtemp indications.

Main Rotor Gearbox Oil: With ship on level ground, verify correct oil level and cleanliness using sight gage. If required by Section 1.101, drain and flush gearbox per Section 1.120.

Main Rotor Gearbox Chip Detector: If required by Section 1.101, clean chip detector per Section 1.115.

Upper Steel Tube Frame: Use an inspection light and mirror to inspect each weld, verify no cracks or corrosion.

CAUTION

Upper steel tube frame is fatigue-loaded and therefore susceptible to fatigue cracks. Inspect thoroughly.

Horizontal Firewall: Inspect upper and lower surfaces of horizontal firewall, especially where bolted to steel structure, for cracks, buckling, or wrinkles. Inspect firewall under fuel tank for leakage (fuel residue).

Fuel Tanks: Inspect condition of visible portion. Verify no leaks. Verify security.

Auxiliary Fuel Tank Fuel Line: Inspect condition. Verify clearance to structure. Verify no leakage. Verify security.

Fuel Return Lines & Pressure Relief Valve (IO-540 only): Inspect condition. Verify no leakage. Verify security.

Fuel Gage Senders & Wiring: Inspect condition. Verify no leaks.

Fuel Tank Vents: Check vent tube connections for security.

Fuel Tank Sump Drains: Verify both drain valves open easily, drain fuel freely, spring closed, and seal completely. Verify D663-1 shut-off clamp on aux tank drain tube seals completely, and inspect clamp and tube for damage and deterioration.

Low Fuel Warning: Turn MASTER switch on. With a clean wooden dowel, gently depress low-fuel sender float in main fuel tank and verify LOW FUEL warning light illuminates. Turn MASTER switch off.

2.410 Inspection Procedures and Checklist (continued)

7. Open Cowling Doors (7A), Remove Tailcone Cowling (7B) & Mast Fairing (9) (cont'd)

Fuel Caps: Inspect condition, to include gasket. Verify security when closed. Verify alignment marks on cap and tank align when cap is fully closed. Verify cap has aluminum bar shown in Figure 12-3A. _____ |

Nuts and Bolts: Inspect all nuts and bolts in this area for movement and looseness. _____

Cabin Bulkhead & Forward Hydraulic Servo Mounts: Inspect bulkhead and servo mounts (if installed) for corrosion, loose rivets, deformation and cracks. _____

Clutch Assembly: Inspect ends of drive shaft and seals on sheave for oil leakage. Inspect shaft for corrosion, especially at shaft-to-seal junctures. Remove any light surface corrosion at shaft-to-seal junctures, and apply B270-21 corrosion-inhibitor. _____ |

Upper Sheave: Inspect sheave grooves. Replace any sheave showing corrosion pitting or flaking of metalized or anodized coatings, wear through anodized coatings, roughness, or sharp ridges. _____

Drive V-Belts (see Section 2.507): Inspect V-belts. Verify no breakage, deterioration of rubber, cuts, fraying, oil, grease, or foreign objects. _____

Actuator Fuses & Holders: Inspect condition. Verify no corrosion. Verify correct fuses (14-volt systems require AGC-3 fuses while 28-volt systems require AGC-1 ½ fuses). Verify twist-to-lock function and security. _____

Actuator Upper Bearing and Strut: Inspect seals on both sides of bearing for damage. Inspect strut, including both rod ends, and check witness holes. Check for fretting between bearing inner races and clutch shaft. Bearing inner races should be torque striped to clutch shaft. If stripes are broken or misaligned, shaft is unairworthy. Check bearing Telatemp. Perform bearing inspection per § 2.503 if Telatemp indication has increased without corresponding increase in ambient temperature. _____

Actuator Lower Bearing: Inspect as much of bearing as can be seen. Inspect fiberglass scroll area at bearing attachment brackets for signs of cracking. Check bearing seals for evidence of deterioration. Inspect lower bearing brackets for looseness or wear. Inspect bearing per § 2.502 if discrepancies are found. _____

Intermediate Flex Plate and Forward End of Tail Rotor Drive Shaft (see Figure 2-5): Inspect flex plate for cracks and fretting. Inspect yoke-to-drive shaft weld for cracks (steel shafts). _____

Tailcone Attachment: Thoroughly inspect all welds in this area for cracks, corrosion, and security of attaching fasteners. Inspect tailcone mounting area for cracks. _____

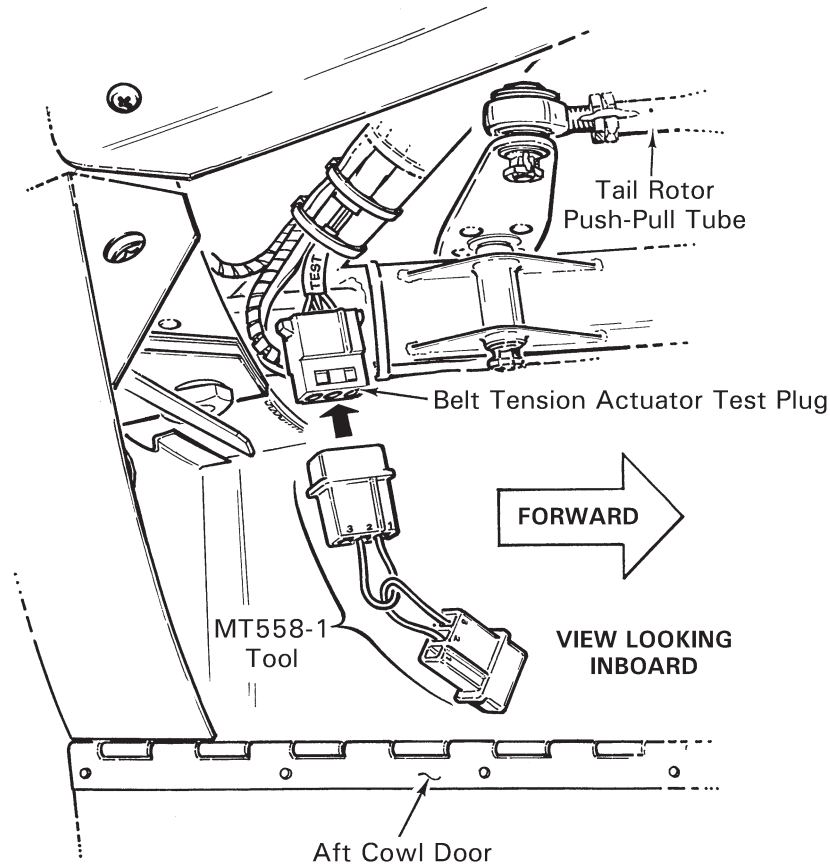

FIGURE 2-6 MT558-1 TOOL INSTALLATION

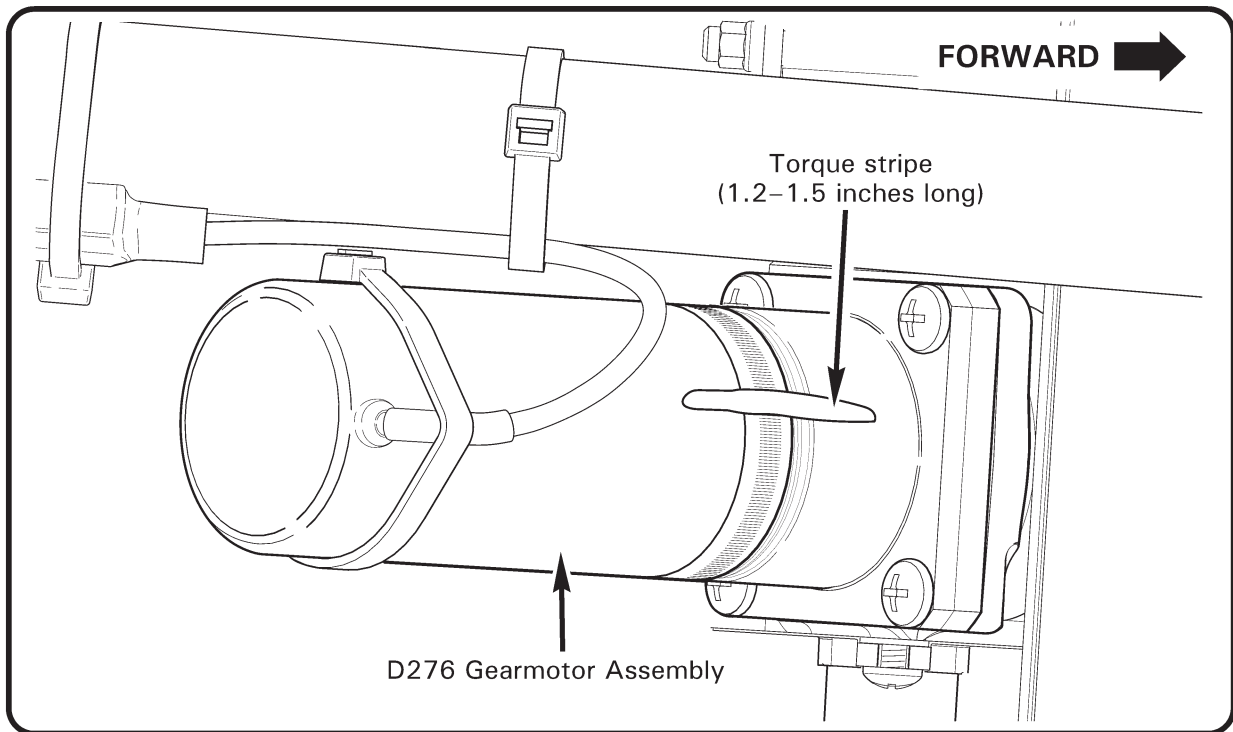

FIGURE 2-6A GEARMOTOR ASSEMBLY TORQUE STRIPE

2.410 Inspection Procedures and Checklist (continued)

7. Open Cowling Doors (7A), Remove Tailcone Cowling (7B) & Mast Fairing (9) (cont'd)

Actuator (CO51): Verify clearance to structure and drive train when fully disengaged. Turn master switch on and engage clutch switch. While actuator is engaging, depress extension limit switch lever (refer to Figure 7-15) and verify gearmotor stops; release lever and verify gearmotor resumes running. Verify integrity of activating cable for extension limit switch. Use an inspection mirror to observe column springs at end of belt-tensioning cycle; springs should snap outward simultaneously. Verify maximum engaged extension limit per Figure 7-15 is not exceeded. Verify clearance to structure and drive train when fully engaged. Verify down-limit stop screw jam nut is tight. _____

Check actuator for failed-closed spring switch as follows (actuator electrical harness must be equipped with "Test" plug per Figure 2-6):

- a. With BATTERY switch on and actuator fully engaged, connect one end of MT558-1 tool to actuator test plug and verify gearmotor remains off. _____

CAUTION

If gearmotor activates when installing MT558-1 tool then a spring switch has failed in closed position; immediately remove MT558-1 to prevent actuator damage.

- b. Disconnect MT558-1 tool, connect opposite end to actuator test plug, and verify gearmotor remains off. _____
- c. Disengage clutch and turn BATTERY switch off. _____
- d. MT558-1 pins 1 & 2 jumper tests wire 98 spring switch; pins 2 & 3 jumper tests wire 91 spring switch (see Figure 14-1D). Replace any malfunctioning switch per § 7.550 before further flight. _____

Gearmotor Assembly Torque Stripe: Refer to Figure 2-6A. Verify torque stripe is not broken or missing. Renew deteriorated torque stripe as required. _____

Lower Drive Sheave: Inspect lower sheave. Replace any sheave showing corrosion pitting or flaking of metalized coating, wear grooves, roughness, or sharp ridges. _____

Sheave Alignment: Verify sheave alignment per § 7.230. Adjust as required. _____

2.410 Inspection Procedures and Checklist (continued)

7. Open Cowling Doors (7A), Remove Tailcone Cowling (7B) & Mast Fairing (9) (cont'd)

Hydraulic Reservoir: Inspect condition. Verify security and no significant leakage. If required by § 1.101, replace filter per § 1.170. Drain and flush hydraulic system per § 1.180 if oil has turned dark or emits bad odor. Add fluid as required.

CAUTION

Cleanliness of hydraulic fluid is vital to proper system operation. Use only clean fluid from sealed containers and avoid contamination from dirty funnels, tubing, etc.

Hydraulic Reservoir Cooling Hose: Inspect condition. Verify hose is secure and is directed at center of reservoir cooling fins.

Hydraulic Pump: Inspect condition. Pump temperature indication should not exceed gearbox temperature indication. Verify security and no significant leakage.

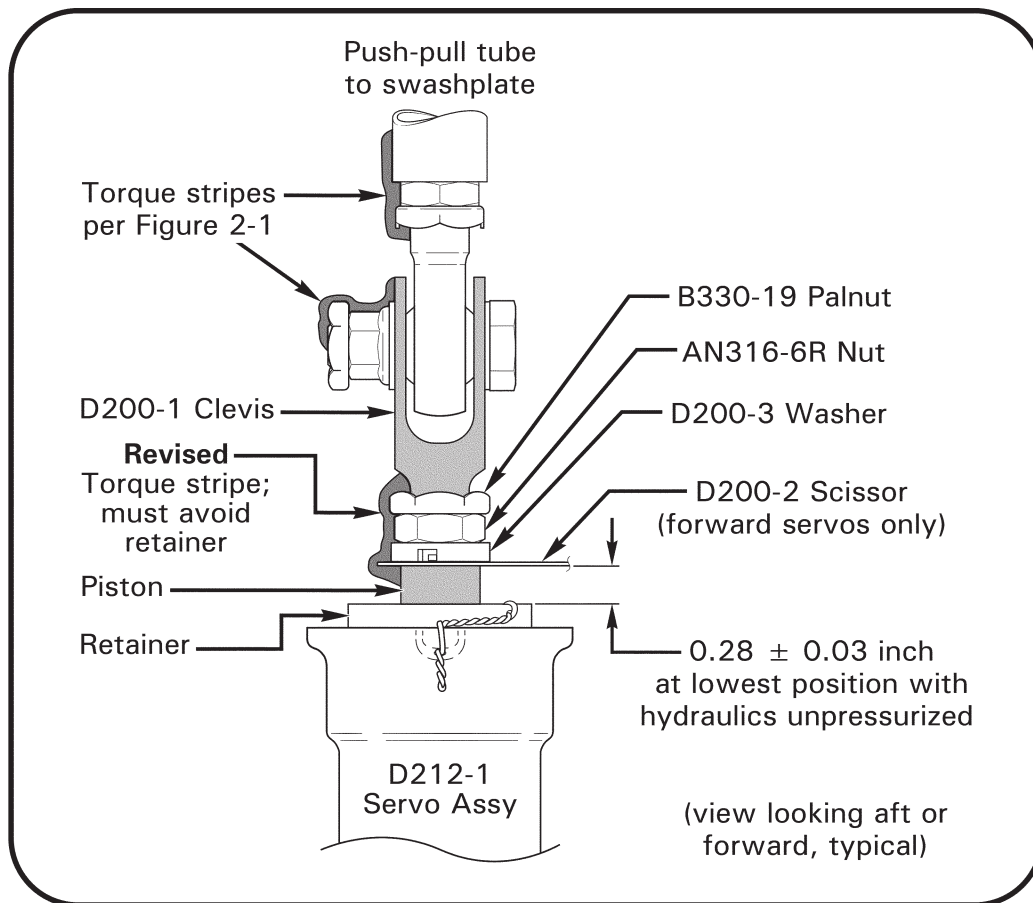

FIGURE 2-7 CLEVIS TORQUE STRIPE

2.410 Inspection Procedures and Checklist (continued)

7. Open Cowling Doors (7A), Remove Tailcone Cowling (7B) & Mast Fairing (9) (cont'd)

Forward Hydraulic Servos: Inspect condition; verify no obvious defects. Hydraulic fluid seepage is permissible ("seepage" is evidence of fluids without flow, drips, or runs) provided fluid does not contaminate MRGB rubber mounts. Verify servo input rod end/clevis area is clean; cleanse area with non-residue, non-alcoholic solvent as required. Verify approximately 0.040 inch total free-play at servo valve input. Inspect rod ends per § 2.120. Verify valve clearance to surrounding structure while flight controls are moved through full range of travel. Inspect condition and verify security of scissors at upper clevis of servos. Inspect clevis security and torque stripe per Figure 2-7.

CAUTION
Use LPS PreSolve to clean hydraulic parts. Do not use alcohol.

Aft Hydraulic Servo: Inspect condition; verify no obvious defects. Hydraulic fluid seepage is permissible ("seepage" is evidence of fluids without flow, drips, or runs) provided fluid does not contaminate MRGB rubber mounts. Verify servo input rod end/clevis area is clean; cleanse area with non-residue, non-alcoholic solvent as required. Verify approximately 0.040 inch total free-play at servo valve input. Inspect rod ends per § 2.120. Verify valve clearance to surrounding structure while flight controls are moved through full range of travel. Inspect clevis security and torque stripe per Figure 2-7.

Hydraulic-Servo Absorbent Pad (Recent Servos Only): If installed, examine white absorbent pad(s); replace pad if damaged. If pad is discolored, remove pad from tray, then use a roller to squeeze out absorbed fluid, or replace pad. Clean tray & install pad.

Aft Hydraulic Servo Supports: Inspect RH and LH support rod ends per § 2.120. Inspect attachment to sheet metal; verify no cracks. Verify security.

Hydraulic Lines & Fittings: Inspect condition. Verify valve clearance to surrounding structure while flight controls are moved through full range of travel. Verify security and no leakage. Verify minimum 0.25 inch clearance between pump hoses and aux fuel tank.

Fasteners and Torque Stripes: Inspect condition and verify security of all fasteners. Renew deteriorated torque stripes per Figure 2-1.

2.410 Inspection Procedures and Checklist (continued)

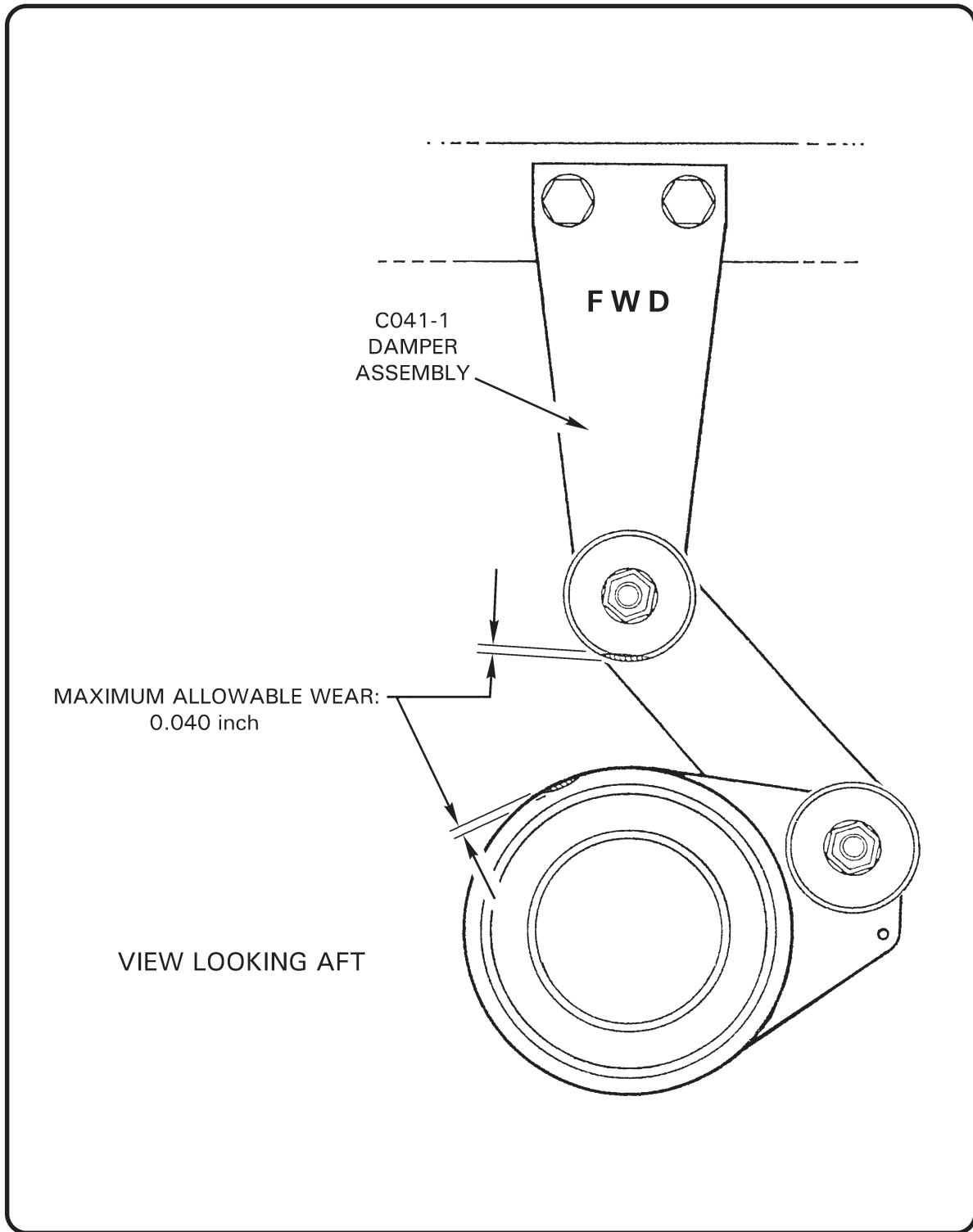

FIGURE 2-8 TAIL ROTOR DRIVE SHAFT DAMPER BEARING INSPECTION

2.410 Inspection Procedures and Checklist (continued)**8. Remove Tailcone Plugs (8A) & Aft Plastic Cover (8B)****NOTE**

Aft plastic cover (8B) is secured with two MS27039C0806 screws on Rev L and subsequent tailcones. On Rev K and prior tailcones ensure screws securing plastic cover are short enough to prevent interference in aft flex plate area.

Tail Rotor Drive Shaft Assembly: Examine accessible portion through inspection holes with inspection light and mirror. Verify no cracks, corrosion, or fretting in fore and aft bonded sleeves. Verify no evidence of drive shaft contact with tailcone bays. Verify no bends, bowing, dents, cracks, or corrosion. Perform tail rotor drive shaft runout per § 7.340. Verify proper installation, security, and operating clearance.

CAUTION

Bends, bowing, dents, cracks and corrosion are cause for immediate replacement of tail rotor drive shaft.

Tail Rotor Push-Pull Tube & Forward Bellcrank: Examine accessible portion through inspection holes with inspection light and mirror. Inspect condition per § 2.121. Verify no nicks, scratches, dents, cracks, or corrosion. Inspect rod end bearings per § 2.122; verify rod ends are centered and palnut and jam nut are tight. Check witness holes for proper thread engagement. Inspect bellcrank and bellcrank mount for nicks, scratches, dents, cracks, or corrosion. Inspect spherical bearings per § 2.122. Verify proper installation, security, and operating clearance. Verify tail rotor guard mounting screw shanks clear push-pull tube.

Tail Rotor Drive Shaft Damper Assembly: Verify no obvious damage. Verify integrity of bearing seals. Inspect bearing housing for excessive wear (see Figure 2-8). Verify bearing's inner race-to-drive shaft torque stripe is intact and no evidence of bearing slippage. Verify proper orientation, security, and smooth operation.

Aft Flex Plate (refer to Figure 2-5): Inspect condition. Verify no obvious damage. If fretting is detected, replace flex plate. Verify bonded washers are installed on both sides of each flex plate arm. Verify security and operating clearance.

Tail Rotor Drive Shaft Aft Yoke: Using inspection hole, check yoke for cracks, fretting, and corrosion.

2.410 Inspection Procedures and Checklist (continued)

8. Remove Tailcone Plugs (8A) & Aft Plastic Cover (8B)

Tailcone Interior: Inspect condition. Verify no cracks in damper mount angle. Verify wear at push-pull tube & bulkhead bushing (6 places) is not excessive. Remove debris. _____

Tailcone Exterior: Inspect condition. Verify drain hole in each bay is clear. Verify no cracks at antenna mounts and battery attachment (if on tailcone). _____

Tailcone Battery (if installed): Inspect condition. Verify no debris between battery box cover and tailcone. Verify security. _____

F050-2 Horizontal Stabilizer (if installed): Inspect condition. Verify security. _____

Strobe Light: Inspect lens and strobe light mount for cracks, loose rivets, and security. If split red/clear lens is installed, verify clear half of lens faces aft. _____

Antennas: Inspect condition. Verify no cracks where antennas mount to tailcone. Verify security. _____

Tailcone Attachment: Inspect condition and security of four bolts attaching tailcone to upper frame. _____

Empennage: Inspect condition. Verify no evidence of tail skid strike. Verify drain holes in lower vertical stabilizer and tail skid are clear. Verify proper installation and security. _____

Tail Rotor Guard: Inspect condition. Verify no cracks or corrosion at attach points. Verify security. _____

Float Stabilizer (if installed): Inspect condition and security. _____

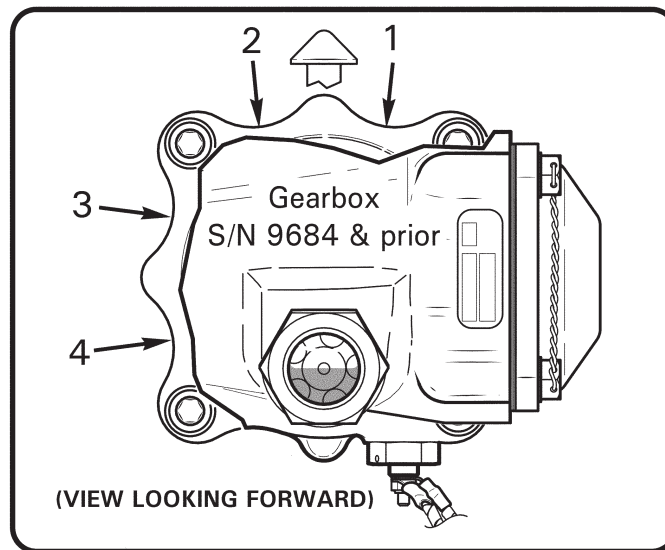

FIGURE 2-8A TRGB INPUT CARTRIDGE INSPECTION

2.410 Inspection Procedures and Checklist (continued)

9. Tail Rotor Gearbox and Tail Rotor

Input Shaft Yoke: Inspect flange and weld for cracks and corrosion. _____

Input Seal: Inspect for leakage. _____

Gearbox: Inspect general condition. Look for leakage. Check oil quantity and cleanliness through sight gage and adjust or flush as required. Check gearbox-to-tailcone mounting security. Inspect output shaft for nicks, scratches and corrosion. Check safety wire on applicable gearbox bolts. Check Telatemp. Gearbox S/Ns 9684 & prior: using 10X magnification, visually inspect four curved surfaces on input cartridge per Figure 2-8A; if cracking is detected, remove gearbox from service and perform C148 Bulkhead Inspection per § 2.595. _____

NOTE

At 500 hours time-in-service or annually, whichever occurs first, remove chip detector and clean varnish from detector’s magnetic probe and adjacent metal body (a toothbrush dampened with solvent works well). Also, drain and flush gearboxes at intervals not to exceed 500 hours time-in-service (refer to § 1.101).

Pitch Control Assembly and C121-17 Push-Pull Tube: Check pitch control assembly for free movement throughout its entire range and for looseness on output shaft (0.25 inch maximum rotational play measured at pitch link attach bolt). Inspect bellcrank for cracks and ensure free movement. Pay special attention to spherical bearing atop stud protruding from underside of pitch control; it is permissible to have a single radial crack in the spherical bearing ball. Inspect aft end of C121-17 push-pull tube for cracks and check rod end for excessive looseness (refer to R44 SB-43A). _____

Pitch Links: Check rod ends for excessive looseness. If equipped with one-piece pitch links, disconnect and rotate inboard end outboard as required to obtain maximum service life. Additionally, an optional A215-012 o-ring may be installed on A115-1 spacer under both bolt heads at pitch control. _____

Tail Rotor Blades: Confirm blades are P/N C029-3 Rev R or subsequent. Inspect blade surfaces and verify no nicks, scratches, cracks, corrosion, voids, debonding, or excessive erosion. Verify tail rotor blade root fitting bearings are not fretting or loose; loose bearing outer race in root fitting requires blade replacement. Verify blades cone toward gearbox. Perform tail rotor blade care per § 30-37. _____

2.410 Inspection Procedures and Checklist (continued)

9. Tail Rotor Gearbox and Tail Rotor

Hub Plates and Hub: Inspect for cracks and corrosion, paying special attention to areas around blade and hub mounting bolts. Ensure teeter hinge bearing outer races move with hub and bearing inner balls and retaining nut and bolt remain stationary when hub is teetered. Hub should move freely on bearings without stiffness or jerkiness. Check teeter hinge bearings for excessive play. For elastomeric bearings inspect per § 2.125. _____

Fasteners and Torque Stripes: Inspect condition and verify security of all fasteners. Renew deteriorated torque stripes per Figure 2-1. _____

10. Open Mast Fairing (9)

Mast Fairing: Inspect condition, especially where stiffeners intersect ribs. _____

Lower Swashplate Scissors: Inspect condition of scissors. Check rod end and bearing play. Check jam nut. _____

Vertical Push-Pull Tubes: Inspect for general condition and corrosion. For manual controls, inspect push-pull tube sleeves at rollers and guide. _____

Rod Ends: Check push-pull tube rod ends per § 2.120. _____

Plastic Rollers and Guide (manual controls): Inspect plastic rollers and guide for cleanliness, security, and deterioration. _____

Pitot Tube: Inspect pitot line and tube, giving special attention to connecting area, for bending, cracking and kinking. Verify pitot tube elbow drain hole is unobstructed. _____

Fuel Tank Vents: Inspect condition and security of fuel tank vent tube clamps. Ensure pitot line is not chafing fuel vent tubes. Check tube connections. Verify tubes are unobstructed and are not kinked, pinched, or chafing. _____

Mast Fairing Ribs: Inspect for cracks especially around mast tube attachments. _____

11. Rotor Hub Area

Swashplate Lower Scissors: Inspect condition. Inspect rod ends per § 2.120. Verify security. _____

Swashplate Upper Scissors: Inspect condition. Inspect rod ends and spherical bearings per § 2.120. Measure scissors play per Figure 2-9. Observe scissor linkage while having someone raise and lower collective. Verify bolt, journals (or spherical bearing balls and spacers), and arm rotate together at each scissor linkage pivot. Verify operating clearance. _____

2.410 Inspection Procedures and Checklist (continued)

11. Rotor Hub Area (continued)

Swashplate Slider Tube: Inspect condition. Verify no cracks at rivet holes or corrosion on base. Verify no damage to, or wear through, anodized tube surface. _____

Remove Swashplate Boot Lower Ty-rap: Lift boot from swashplate. Using an inspection mirror, inspect area between main rotor drive shaft and inside of slider tube. Verify no corrosion and no debris. Verify no boot damage. _____

Swashplate: Inspect condition. Verify 0.020 inch maximum radial play between swashplate ball and slider tube. Rotate rotor by hand and verify operating clearance and no rough or dry bearings. _____

Swashplate Tilting Friction: Observe swashplate ball from below and have someone move collective stick slowly up & down. Verify swashplate ball immediately moves with swashplate when swashplate reverses direction. Movement of swashplate without attendant ball movement indicates axial play between ball and swashplate; adjust swashplate tilting friction per § 8.413. _____

Intentionally Blank

2.410 Inspection Procedures and Checklist (continued)

11. Rotor Hub Area (continued)

Install Swashplate Boot Lower Ty-rap: Verify correct boot position and security and no boot damage. _____

Hub: Inspect condition. Verify no nicks, scratches, gouges, or corrosion. If main rotor imbalance is suspected, check teeter and coning hinge friction per § 28-32. Verify no brown or black residue (indicates bearing wear). _____

Hinge Bolts: Inspect condition. Verify cotter pins are in place and secure. Verify bolt heads and nuts are torque striped to thrust washers. _____

Pitch Links and Rod Ends: Inspect condition. Inspect rod ends per § 2.122, including centering. Verify security, including jamnut tightness and proper safety wiring. _____

Fasteners and Torque Stripes: Inspect condition and verify security of all fasteners. Renew deteriorated torque stripes per § 2.140. _____

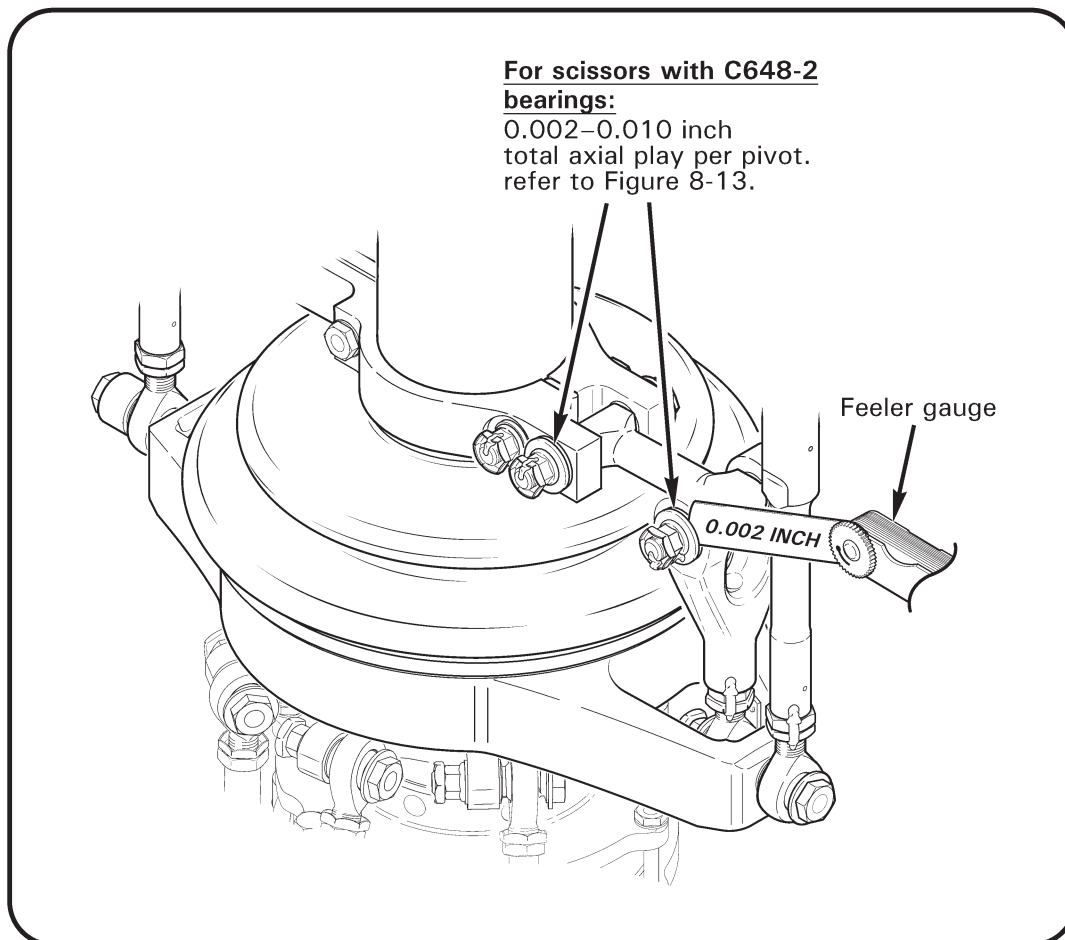

FIGURE 2-9 MEASURING UPPER SWASHPLATE SCISSOR AXIAL CLEARANCE

2.410 Inspection Procedures and Checklist (continued)

12. Main Rotor Blades

Boots: Inspect condition. Verify no boot damage or oil leakage. Verify proper boot position and security. Verify sufficient clearance from hub assembly through full control travel. _____

Blade Spindles & Root Fittings: Inspect area for damage per § 28-43. Verify proper installation and security of visible fasteners. Renew deteriorated torque stripes per Figure 2-1. _____

Main Rotor Blade Tip Maintenance: Perform main rotor blade tip maintenance per § 28-60. _____

Main Rotor Blade Inspection: Inspect skins and doublers for scratches and corrosion per § 28-41. Inspect blades for dents and local deformations per § 28-42 and for voids per § 28-44. As required, wax blades with soft cleaning cloths using carnauba-type wax (such as SC Johnson® Paste Wax). Ensure tip cover and blade tip drain holes are unobstructed. _____

WARNING

Structural damage may occur if compressed air is applied to blade tip drain holes.

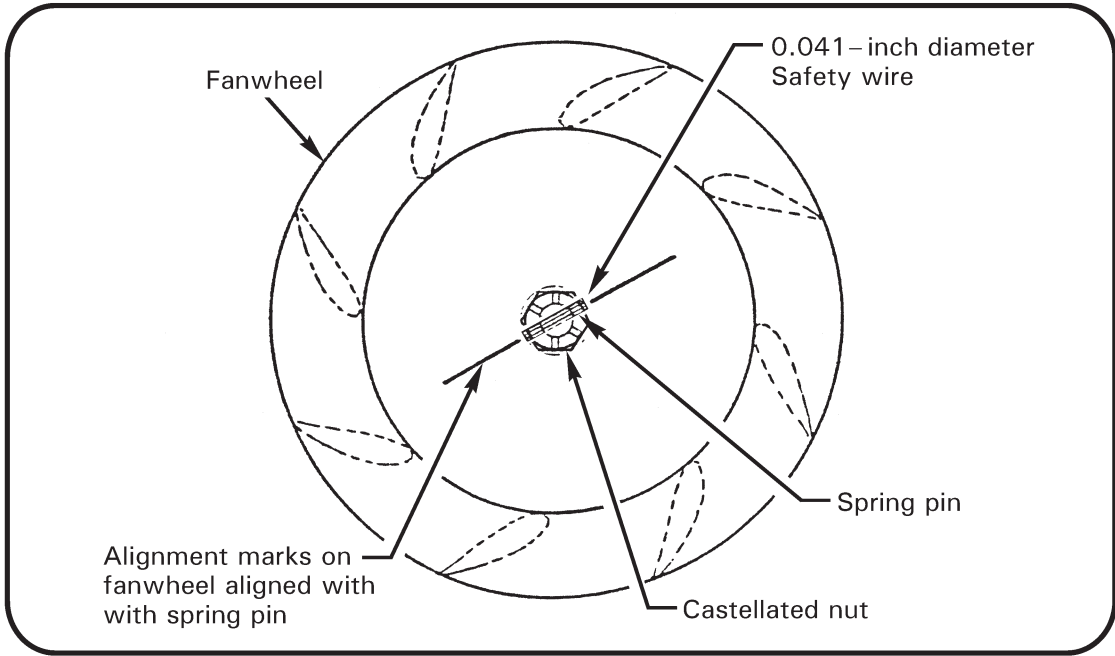

FIGURE 2-10 FANWHEEL ALIGNMENT MARKS

2.410 Inspection Procedures and Checklist (continued)

13. Scroll Area

Fanwheel Assembly: Clean and inspect fanwheel assembly for cracks and corrosion. Check leading edge of vanes for damage. Verify spring pin and fanwheel alignment marks are aligned (see Figure 2-10); remove fanwheel and inspect mating surfaces for damage if misalignment is evident.

Fiberglass Scroll: Inspect fiberglass scroll for cracks and contact marks from fanwheel. Inspect flexible seal around scroll inlet for any rips or damage. Inspect vane assembly in right upper scroll for damage. Verify drain hole is unobstructed.

Scroll Metal Inlet Lips & Gap: Verify 0.030 / 0.090 inch gap between lips and fanwheel inlet (elongate lip attach holes as required to adjust gap).

Lower Bearing Brackets: Refer to Figure 2-11. Visually inspect A185 brackets and attaching screws/rivets for evidence of fretting or looseness. If evidence of looseness is found, contact RHC Technical Support for repair instructions. On lower A185 bracket, apply torque seal in a horizontal stripe across both outboard screws/rivets to lower scroll to facilitate future inspections.

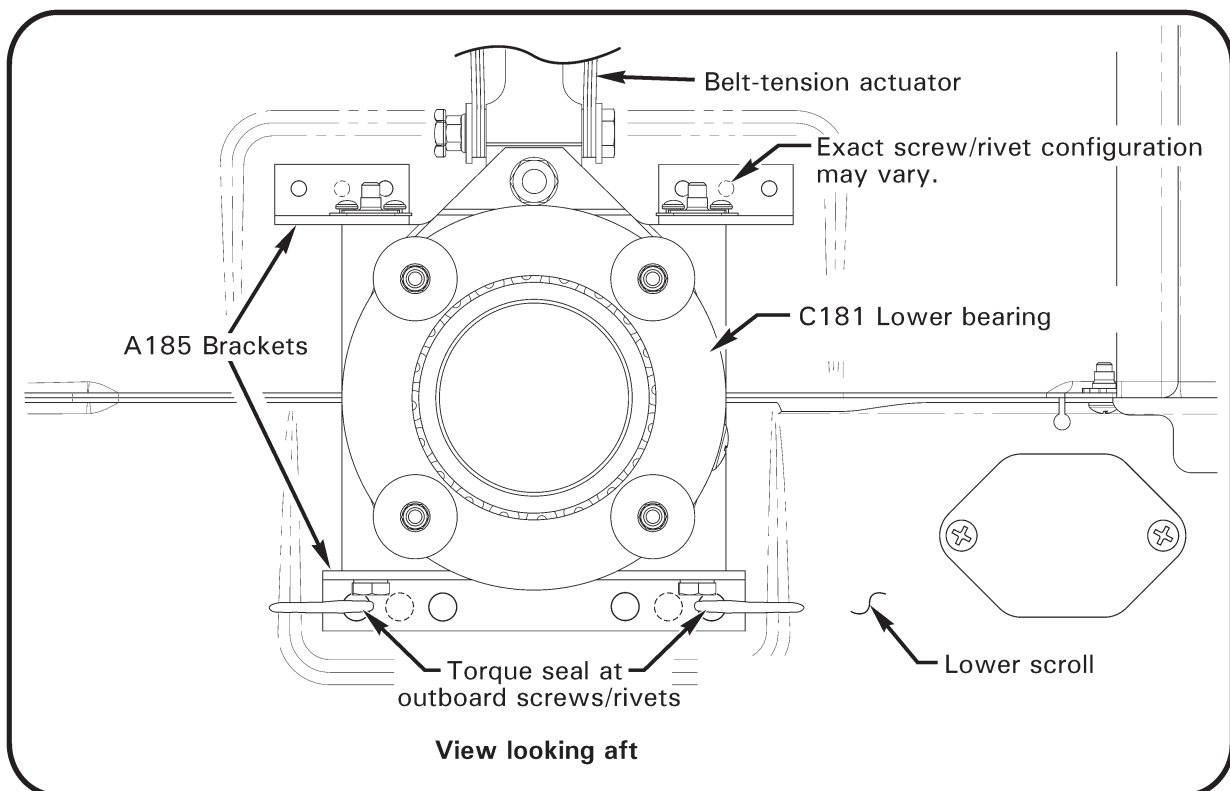

FIGURE 2-11 ACTUATOR LOWER BEARING A185 BRACKETS

2.410 Inspection Procedures and Checklist (continued)

14. Engine

Refer to § 1.101. Refer to Lycoming Operator’s Manual (P/N 60297-10 sections 4 and 5), Lycoming SI 1080, and applicable engine component manufacturer’s maintenance publications for 100-hour or annual inspection and service procedure. _____

Engine Cooling Panels: Inspect condition. Pay particular attention to panel(s) mounting oil cooler(s) and panel attached to alternator cooling hose. Verify no cracks or missing or loose fasteners. Verify security. _____

Alternator & Pulley: Inspect condition. Verify steel pulley (use magnet); aluminum pulley is not approved. Verify security. Verify electrical wiring security. _____

Alternator Belt: Inspect condition. Replace belt if there are any cracks, missing teeth, or delamination. Check tension per Lycoming Service Instruction 1129 (latest revision). Verify proper belt alignment. _____

Emergency Spare Alternator Belt: Remove if installed. _____

Alternator Cooling Hose: Inspect condition. Verify no obstructions or holes. Verify security. _____

Air Conditioning Refrigerant Lines (if installed): Verify security, no damage, and clearance to adjacent structure. Verify dust caps installed on servicing fittings at vertical firewall. _____

Air Conditioning Compressor (if installed): Verify security. _____

Air Conditioning Compressor Drive Belt (if installed): Inspect condition. Verify 4.5/5.5 pounds force applied at mid-span of belt causes 0.11/0.17 inch belt deflection; adjust as required. _____

Muffler Elbow & Tailpipe Shields: Verify no cracks in shields and shield attaching brackets. Verify clamp security. _____

2.410 Inspection Procedures and Checklist (continued)

15. Exhaust System

Muffler: Remove muffler heater shroud screws, and open shroud. Inspect muffler outer wall for cracks, deformation, and ruptures. Pay particular attention to tailpipe and riser attachment areas, welds, clamps, supports, riser flanges and gaskets. Pressurize muffler with low pressure air and inspect for leakage. Close and secure heater shroud.

16. Landing Gear

Skids and Shoes: Inspect left and right landing gear skids and skid shoes; minimum allowable shoe thickness is 0.05 inch. Verify drain holes are open (not applicable to float landing gear).

Struts and Elbows (open fairings if installed): Inspect for cracks and corrosion, especially at elbow joints. Inspect weld area at bottom of strut for cracks.

Landing Gear Fairings (if installed): Inspect for cracks and loose rivets. Verify security.

Crosstubes: Inspect, especially at elbow joints, for cracks and corrosion. With helicopter on level ground, measure distance from ground to tail skid. If dimension is less than 30 inches, one or both cross tubes must be replaced (see Chapter 5).

Landing Gear Attach Points: Check forward attach points for loose rivets, cracks, buckling, and fretting. Check bearing mounts for loose swages and worn bearings.

Utility Floats (if installed): Inspect for damage. Refer to applicable Pilot's Operating Handbook for proper inflation pressure.

Pop-out Floats (if installed) Pressure Cylinder & Valve: Inspect condition. Verify security. Verify pressure gage indicates correct pressure for ambient temperature; refer to placard on cylinder for limits.

Pop-out Floats (if installed) Inflation Manifold: Inspect condition. Verify no chafing or pinching of hoses, especially where hoses pass thru structure.

Pop-out Floats (if installed): Inspect condition of stowed floats. Verify no holes, cuts, tears, abrasion thru, or unraveling of, float covers. If cover damage is found, inflate and inspect floats. Verify all float cover snaps and hook-and-loop fasteners are properly secured. Verify float-to-skid attachment security.

NOTE

Annually apply A257-7 dry-film lubricant (see § 23-78) to float cover snap mating surfaces. Annually perform § 5.630 leak check. Every three years, perform § 5.640 emergency inflation test.

2.410 Inspection Procedures and Checklist (continued)

17. Cabin

General interior: Inspect condition. Verify general cleanliness of cabin and seat compartment interior. Verify no loose objects or equipment, which could foul controls, or injure occupants in a hard landing. Verify legibility of placards and markings. Verify serviceable condition of switches, knobs, handles, and other controls. _____

Rear Seat-Bottom Suspension Straps: Inspect condition and security. _____

Seat Belts and Shoulder Harnesses: Inspect for fraying and broken stitching. Check inertia reels for proper operation by pulling harness quickly to verify locking function. Check buckles for proper operation. Check belt and reel attach points for security. _____

<p>NOTE</p> <p>TSO tag not required on factory installed harnesses.</p>
--

Heated Seats (if installed): Perform heated seats inspection per § 15.240 Part D. _____

Cyclic Guard (if installed): Inspect condition of cyclic guard. Inspect all welds for cracks. Verify no corrosion. Verify security and proper operation. _____

Cockpit Camera (if installed): Inspect condition. Verify camera lens is clean. Perform functional check per § 37-140 Part D. _____

Exterior: Inspect condition. Inspect cabin exterior for nicks, scratches, dents, cracks, corrosion, fretting, or loose rivets. Loose rivets may be indicated by cracked paint and/or black residue around heads. Verify general cleanliness. _____

Windshields & Windows: Inspect condition. Verify no significant UV yellowing. Minor defects or imperfections that do not impair pilot visibility are acceptable. Refer to § 27-30 for damage and repair limits. Verify security. _____

Yaw String: Inspect condition. Verify minimum string length is 3 inches on each side of clip. Verify security. _____

Doors: Inspect for cracks around hinges and latches. Check vents for operation. Ensure hinge pins are secured with cotter pins. Check tightness of hinge mounting screws. Verify proper operation of door latching and locking mechanisms. _____

Skin: Inspect skin for damage. Inspect for loose rivets, indicated by cracked paint and/or black residue around heads. _____

2.410 Inspection Procedures and Checklist (continued)

17. Cabin (continued)

Static Ports: Inspect static ports for obstructions. If fixed utility floats are installed, verify air dam installed aft of both static ports. _____

Left & Right Navigation Lights: Inspect condition. Verify no cracks where right and left navigation lights mount to fuselage. Verify red left, green right, lens cleanliness, clarity, and security. Verify proper operation. _____

Landing & Taxi Lights: Inspect condition. Verify lens cleanliness, clarity, and security. Verify proper operation. _____

Landing Light Retainer & Support: Inspect condition. Verify no cracks where retainer mounts to support. Verify security. _____

Chin Drains (R44 Clipper): Verify no obstructions. _____

18. Special Equipment (if installed)

Peak Beam Searchlight: Check for proper operation. Align beams by focusing both lights to smallest spot possible and shining against a wall at least 100 feet away. Verify both spots hit same point within one foot. _____

Nose Gimbal and Monitors: Turn power on and verify infrared units complete cool down sequence in manufacturer’s recommended time. Verify gimbal steers smoothly in azimuth and elevation. Check focus and zoom of infrared/video. Check for clear images on monitors. Verify retractable monitor retracts without interference. _____

Spectrolab Searchlight: Verify light starts and cooling fan operates. Verify searchlight steers smoothly in azimuth and elevation. For slaved units, turn on slaving and verify light follows nose gimbal approximately. _____

FM Radios: Verify radios transmit and receive properly and control head programs radios properly. _____

Video Tape Recorder: Verify all video tape recorder modes operate properly and remote control correctly controls modes. _____

Overhead Light: Verify overhead light on/off. _____

Transmit and Intercom Switches: Verify proper operation of special transmit and intercom switches. _____

Talent Light: Verify talent light on/off, acceptable friction. _____

Micro Cameras: Verify all micro cameras are selectable from video switcher and produce focused, upright images on monitors. _____

TV Tuner: Verify TV tuner receives broadcasts (video clear on monitors, audio clear in headset). _____

2.410 Inspection Procedures and Checklist (continued)

18. Special Equipment (if installed) (continued)

Microwave Antenna: Verify omnidirectional microwave antenna extends/retracts properly. Verify up/down indicator lights function properly. _____

Electromagnetic and Radio Frequency Interference: With all special equipment turned on, check for EMI/RFI with tach, COM, intercom, compass, or other systems. _____

19. Life-Limited Parts, Additional Component Maintenance, ADs, & SBs

Life-Limited Parts: Refer to helicopter maintenance records and § 3.300. Replace life-limited parts as required. Verify components installed have sufficient time remaining for projected operations. _____

Airworthiness Directives: Verify applicable airframe, engine, and accessory Airworthiness Directives (ADs) have been performed according to AD compliance procedures. Some aircraft may be affected by ADs that require recurring inspections at less than 100-hour or annual intervals. Recent U.S. Airworthiness Directives are available online at www.faa.gov.

Service Bulletins: Verify applicable airframe, engine, and accessory Service Bulletins (SBs) have been complied with according to manufacturers' instructions. Some aircraft may be affected by SBs that require recurring inspections at less than 100-hour or annual intervals. RHC Service Bulletins are available online at <https://robinsonheli.com>, under the Publications tab. _____

20. Required Documents and Placards

Documents: Check that required documents (Airworthiness Certificate, Registration, applicable Radio Station License, applicable Pilot's Operating Handbook, Equipment List/Weight & Balance Data) are on board, legible, and current. _____

Placards: Verify required placards are properly installed, legible, and current. Refer to applicable Pilot's Operating Handbook Section 2 for placard requirements. _____

21. Inspection and Access Covers

Foreign Objects Removed: Verify all tools, loose hardware, rags, and other foreign objects are removed from helicopter. _____

Covers Closed and Secure: Install/close all inspection and access covers removed in preceding steps. Verify security of all access covers. _____

Clipper I Air Box Sealed: Ensure air box cover perimeter is sealed with aluminum tape (Clipper I models only). _____

2.410 Inspection Procedures and Checklist (continued)**22. Maintenance Records**

Maintenance Records: Verify maintenance records are accurate, legible, and complete. Enter maintenance performed (such as part replacement, equipment adjustments, servicing, and lubrication) and inspection data. Data must include a description of (or reference to data acceptable to the Administrator) the work performed, date, helicopter total time in service, signature, certificate type and certificate number of person approving aircraft for return to service. _____

SHEAVE ALIGNMENT LEFT: _____

SHEAVE ALIGNMENT RIGHT: _____

TRDS RUNOUT: _____

CHECKLIST COMPLETE:

Mechanic's signature: _____ Date: _____

Intentionally Blank

2.500 SPECIAL INSPECTIONS

2.501 Upper and Lower Clutch Actuator Bearings Inspection

The actuator upper bearing is located on the clutch shaft, and the actuator lower bearing is located on the fanshaft. Failure of either actuator bearing in flight could cause loss of power to rotor system and result in a serious accident. Refer to Section 2.110 for general indications of bearing failure. In addition, just before failure of an actuator bearing, the clutch light may flicker (on and off in less than one second) constantly or illuminate for longer than normal in-flight retensioning time of up to 8 seconds, then off). Flight should not be resumed until cause of abnormal clutch light illumination has been determined.

Perform the following bearing inspections whenever an actuator bearing discrepancy is suspected or fanwheel is removed:

2.502 C181 Lower Bearing Inspection

1. Remove scroll and fanwheel per Section 6.210.
2. Support clutch drive shaft aft of sheave. Disconnect lower end of belt tension actuator from bearing housing.
3. Rotate bearing housing with finger tips. Verify no roughness, scraping or excessive looseness (0.010 inch maximum axial play). Verify no seal damage and no heat damage. Lubricate bearing per Section 1.140.
4. Carefully inspect inner race bearings on fanshaft. Forward bearing inner race is torque-striped to fanshaft two places 180 degrees apart; cracked or broken torque stripes indicate movement. No movement or fretting is allowed between inner race and fanshaft. Verify no distortion due to bearing outer races rotating in housing. Replace fanshaft & bearing assembly if indications of movement are noted.
5. Reinstall fanwheel per Section 6.220.
6. Check and adjust fanwheel dynamic balance per Section 6.240.

| 2.503 C184 Upper Bearing Inspection

1. Disconnect lateral centering strut from left side of bearing housing.
2. Disconnect bearing housing from actuator. Run actuator to its full disengage position by adjusting actuator down-limit screw upward. Refer to Figure 7-15. Do not allow upper and lower scissors' attaching screw heads to contact each other.
3. Rotate bearing housing and check for sound or feel of any roughness, scraping, or excessive looseness. Verify no seal damage, loss of lubricant or heat damage.
4. Carefully inspect inner races of bearings on clutch shaft. Aft bearing inner race is torque-striped to clutch shaft two places 180 degrees apart; cracked or broken torque stripes indicate movement. Verify no fretting between bearing inner races and shaft. Verify no distortion due to bearing outer race(s) rotating in bearing housing. Remove bearings and inspect bearing and shaft if indications of movement are noted.
5. Connect centering strut and actuator to bearing housing. Adjust actuator down-limit stop screw so there is a delay of less than 5 seconds between clutch engagement and rotor turning during start-up.

2.507 V-Belt Inspection

If any of the following conditions are observed, replace V-Belts in a matched set per Section 7.280.

1. Bottom of belts cracking.

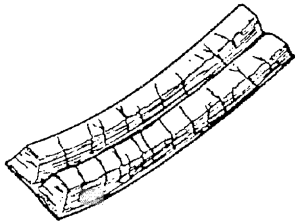

CAUSE	REMEDY
Belt slipping causing heat build-up and gradual hardening of undercord.	Return actuator to RHC for servicing.

2. Top of tie band frayed or damaged.

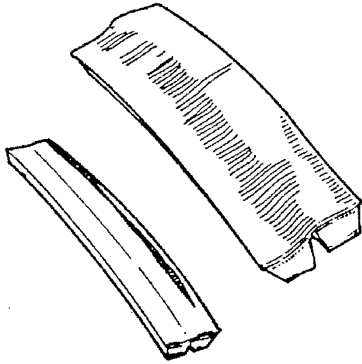

CAUSE	REMEDY
Surrounding structure interfering with normal operation of belt.	Reposition affected sheave for proper clearance and align sheaves per Section 7.230.
Foreign material contacting belt.	Remove foreign material

3. Top of tie band blistered or perforated.

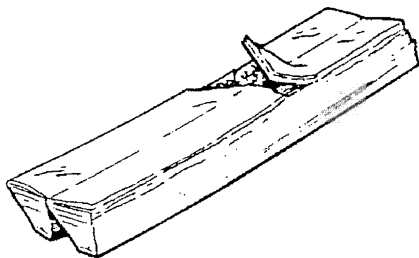

CAUSE	REMEDY
Foreign material accumulating between belts.	Check for and remove foreign material.

FIGURE 2-12 V-BELT DISCREPANCIES

2.507 V-Belt Inspection (cont'd)

4. BELT CUT ON BOTTOM

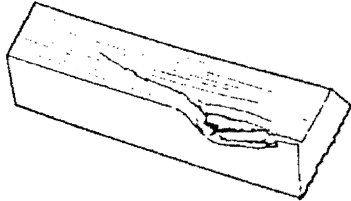

Cause	Remedy
Belt ran over sheave and came off, or belt forced over sheave flange during installation without proper slack.	Check belt tension per Section 7.283 and upper sheave alignment per Section 7.230.
Foreign material fell into belt drive making belt come off.	Remove foreign material if any. Install new belts properly per Section 7.280

5. BELT RIDING OUTSIDE SHEAVE GROOVE

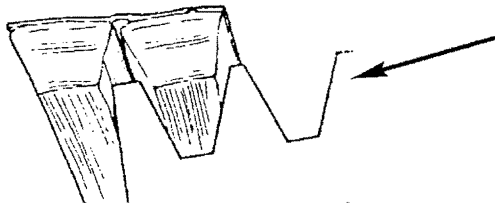

V-belt has jumped one groove forcing belt out of sheave.

CAUTION

If belt condition shown is allowed to run in specified condition, failure would progress as shown below.



Cause	Remedy
One belt separated from tie band	Both belts separated from tie band



Cause	Remedy
Improper belt tension, misalignment of sheaves and/or foreign object struck belt forcing it from its normal path.	Replace V-belts per Section 7.280; align upper sheave per Section 7.230.

FIGURE 2-12A V-BELT DISCREPANCIES

2.508 Lower Sheave V-Belt Wear Pattern Inspection

Observe wear patterns in paint primer in all eight grooves of lower V-belt sheave. Wear patterns on both sides of all eight grooves should appear very similar. Wear patterns which vary in width less than a 3-to-1 ratio groove to groove are acceptable.

If wear pattern is noticeably different from groove to groove, inspect sheave grooves for roughness or excessive wear and replace V-belts per Section 7.280. If wear patterns are all similar and alignment and condition of belts and sheaves are satisfactory, no further action is required.

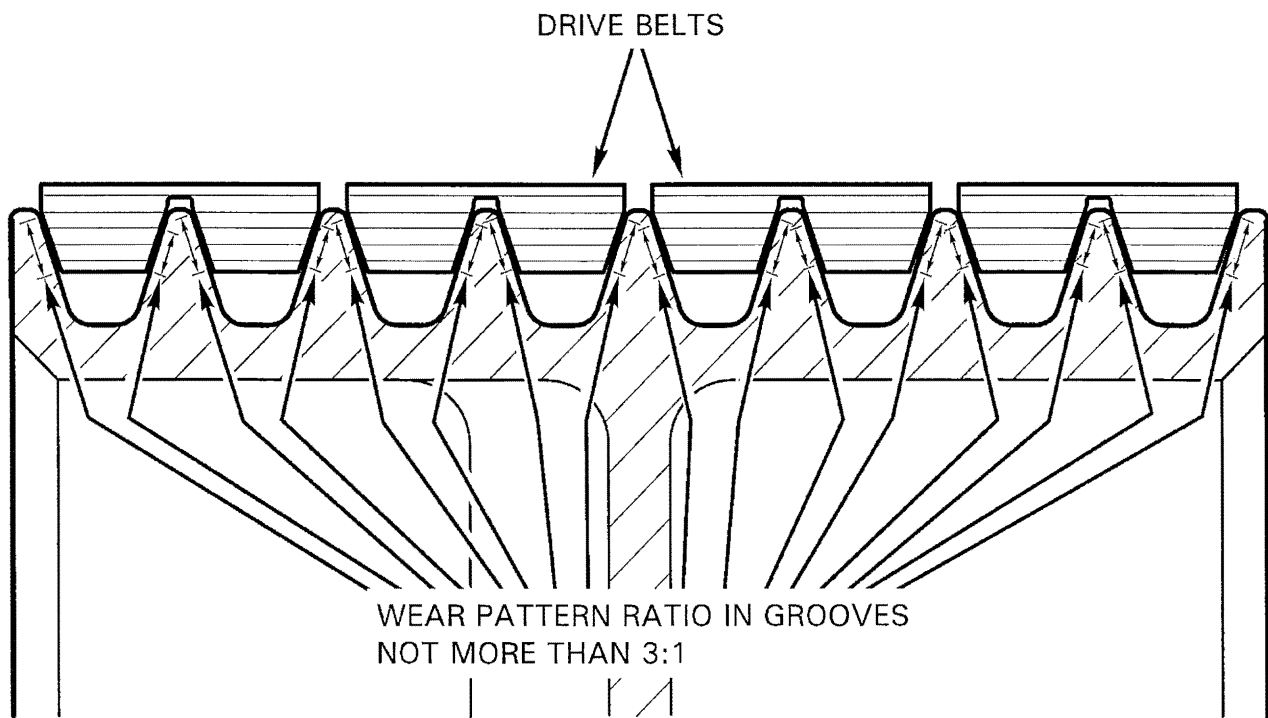

FIGURE 2-13 LOWER SHEAVE V-BELT WEAR PATTERN

| Intentionally blank

2.510 Tail Skid Strike

The tail skid strike inspection is listed in two parts, A and B. Part A concerns scuffing of tail skid. Part B is concerned with bending or breaking of tail skid and/or buckling of lower vertical stabilizer.

- A. If evidence of scuffing is found on tail skid, inspect helicopter as follows:
 - 1. Visually inspect tail rotor blades for evidence of solid object or ground contact. If tail rotor damage is found, inspect tail rotor for strike per § 2.520. _____
 - 2. Visually inspect lower vertical stabilizer for cracks and loose rivets at tail skid and lower vertical stabilizer attach points. _____
 - 3. Visually inspect tail rotor guard for bending or cracking at attach points. _____
 - 4. Visually inspect empennage assembly attach points for buckling, loose rivets, or cracking. _____
 - 5. Visually inspect tailcone assembly for buckling and loose attach bolts. _____
 - 6. Visually inspect upper frame for yielding. _____

- B. For tail skid bending or breakage, or buckling of lower vertical stabilizer, perform the following inspections in addition to those listed in Step A.
 - 1. Measure tail rotor drive shaft runout per § 7.340. _____
 - 2. Remove tailcone per § 4.300. Visually inspect (8) tailcone mounting holes [(4) tailcone & (4) upper frame] and verify no elongation of holes (0.454-inch diameter maximum). _____
 - 3. Remove empennage assembly per § 4.600. Remove tail rotor gearbox per § 7.410. _____
 - 4. Perform § 2.595 Inspection After Stabilizer Damage. _____
 - 5. As applicable, visually inspect F044-1 mount or C044-1 horizontal stabilizer attach points and verify no elongated holes (0.386-inch diameter maximum), loose rivets, or buckling. _____
 - 6. Remove lower vertical stabilizer per § 4.620. Visually inspect (10) attach points. Verify no elongated holes (0.266-inch diameter maximum bolt holes), buckling, cracks, or loose rivets. _____
 - 7. Remove tail rotor guard per § 4.400. Remove D082-1 mount. Visually inspect guard, mount, & blocks; verify no deformation & no elongation of attach holes. _____

Intentionally Blank

Intentionally Blank

2.520 Tail Rotor Strike

Tail rotor strike inspection is listed in two parts, A and B. Part A concerns damage received by a tail rotor blade due to contact with a small stone, tall grass, or some small object contacting rotor blade in free air. Part B is concerned with sudden stoppage of tail rotor due to ground or solid object contact causing skin penetration, or trailing-edge bending, of a tail rotor blade or blades.

A. Contact with Small Stone, Tall Grass, or Other Small Object in Free Air

- 1. Inspect blade(s) per § 30-30. _____
- 2. Check tail rotor drive shaft run-out per § 7.340. If run-out exceeds 0.025 inch at any location, shaft must be replaced or repaired. _____
- 3. Remove tail rotor assembly per § 30-10. _____
- 4. Measure TGB output shaft's radial runout at cylindrical outboard end; maximum allowable TIR is 0.005 inch. _____
- 5. Measure TGB output shaft's teeter bolt hole; 0.3760 inch maximum allowable diameter and no elongation. _____

B. Sudden Stoppage of Tail Rotor due to Ground, or Solid Object Contact Causing Bending or Shearing of Blade(s)

- 1. Perform inspections per Part A. _____
- 2. Remove tail rotor assembly per § 30-10 and tail rotor gearbox per § 7.410 and return to RHC for repair, or replace. _____
- 3. For D196-1 aluminum shaft assembly only (if installed): Replace next higher assembly D224-2 shaft assembly. _____
- 4. For C196-1 steel shaft assembly only (if installed):
 - a. Check tail rotor drive shaft run-out per § 7.340. If run-out exceeds 0.025 inch at any location the shaft must be replaced. _____
 - b. Verify no nicks, scratches, twisting, or dents. Nicks and scratches may be polished out to a maximum of 0.003 inches deep. Replace shaft if twisted or dented. _____
 - c. Strip paint back at least 2 inches from welds at forward end of drive shaft and magnetic particle inspect (refer to § 23-41) stripped area; replace shaft if cracked. _____
- 5. Replace aft and intermediate flex plates. _____
- 6. Visually inspect tailcone & empennage for evidence of a tail rotor blade strike. _____
- 7. Visually inspect main rotor system for collateral damage. _____
- 8. Perform § 2.595 C148 Bulkhead Inspection. _____

2.530 Main Rotor Strike

The main rotor strike inspection is listed in two parts A and B. Part A concerns contact of main rotor blades with object in free air such as small stones, brush, small birds, etc. Part B is concerned with sudden stoppage of main rotor due to ground or solid object contact.

- A. If main rotor blade has contacted a small object in free air such as small stones, brush, small birds, etc the main rotor blades should be inspected as follows:
 - 1. Main rotor blades should be inspected for evidence of nicks, scratches, dents, etc. per Section 9.130. _____
 - 2. Visually inspect trailing edge of blade for evidence of buckling or bending. This will be most evident near root of blade. _____

CAUTION

If evidence of buckling is found on a main rotor blade it will be considered to have sudden stoppage and sudden stoppage inspection must be used to inspect the entire rotorcraft

- B. If main rotor blade or blades have contacted ground or a solid object, they must be inspected for sudden stoppage. Sudden stoppage is evident when buckling or bending of the main rotor blades has occurred. Use the following procedure for inspecting rotorcraft after main rotor sudden stoppage has occurred:
 - 1. Check the tail rotor drive shaft run-out Section 7.340. _____
 - 2. Remove the following components and return to a Robinson Helicopter Company approved overhaul facility for inspection and/or repair.
 - C005 Main Rotor System _____
 - C006 Main Rotor Gearbox _____
 - C018 Clutch Assembly _____
 - C947-1 Forward Flex Plate _____
 - C907 and C908 Yokes _____
 - 3. Inspect engine for sudden stoppage per engine manufacturer's instructions. _____
 - 4. Dye penetrant inspect upper rotating swashplate for cracks and/or deformation. _____

2.540 Rotor/Engine Overspeed

Overspeed inspections are determined by severity of overspeed. Inspection is listed in three parts: A, B, and C. Part A concerns inspection of rotor system due to overspeed between 108% and 114%. Part B is concerned with inspection of rotor system due to overspeeds at or above 114%. Part C is concerned with engine overspeed inspections.

A. For rotor overspeeds between 108 and 114%:

NOTE

Refer to Part C if a power-on overspeed occurs.

1. Check main rotor and tail rotor dynamic balance. Compare pre-overspeed and post-overspeed balance.

CAUTION

Any change in rotor dynamic balance greater than 0.3 ips requires inspection per Part B.

2. Remove main rotor blades. Drain pitch bearing housings. Remove outer blade boot clamps and fold boots away from pitch horns. Rotate spindles to verify no brinelling of pitch bearings.

NOTE

Bearings have a high preload; slight drag is normal. If roughness is evident, return blade and spindle assembly to RHC-authorized overhaul facility for repair.

3. Visually inspect main and tail rotor blades.
4. Check tail rotor drive shaft run-out per Section 7.340.

B. If an overspeed at or above 114% is reported or suspected or if balance changes or pitch bearing roughness is evident, perform following inspections in addition to Part A.

NOTE

Refer to Part C if a power-on overspeed occurs.

1. Perform inspection per Part A.
2. Check coning hinge bolts for evidence of bending. Replace any bent bolts.
3. Coning hinge bolts, washers, and journals must be magnetic particle inspected. Replace any cracked bolts, journals or washers.

2.540 Rotor/Engine Overspeed (continued)

4. Visually inspect hub and dye penetrant inspect any areas suspected of having cracks. Dye penetrant inspections are performed using instructions supplied by manufacturer of penetrant kit.
 5. Reinstall blades and check balance. If a change in balance is evident, rotor system should be returned to an approved RHC overhaul facility for inspection and/or repair.
- C. Determine percent engine overspeed from engine tachometer indication using following formula:

$$\text{Percent engine overspeed} = \frac{\text{Engine tachometer indication} \times 2665}{2800} - 100$$

NOTE

102% engine tach indication equals 2718 actual engine RPM.
The engine is rated at 2800 RPM.

Refer to Lycoming Service Bulletin 369 (current revision) for engine overspeed inspection requirements.

2.550 Hard Landing

The hard landing inspection is listed in two parts: A and B. Part A concerns yielding (bending) of the cross tubes due to hard landing such as hovering autorotations or run-on landings that do not apply side loads to the landing gear. Part B is concerned with hard landings that, in addition to yielding of cross tubes, has yielding of steel tube frames or fuselage primary structure.

NOTE

Side loads show up in the airframe as buckles and bent steel tube structure.

2.550 Hard Landing (continued)

- A. Yielding of cross tube due to hard landing with no side loads:
1. Check tail rotor drive shaft run-out per § 7.340.
 2. Visually inspect main rotor blades for oil canning of skins and buckling. See § 9.130 for inspection and repair of main rotor blades.
 3. Check landing gear cross tubes for yielding beyond serviceable limit. Place rotorcraft on level ground, and measure from tip of tail skid to ground. If less than 30 inches, one or both cross tubes must be replaced.
 4. Check and adjust sheave alignment per § 7.230.
 5. Inspect front seat structure for yielding.
 6. Inspect aft seat structure for yielding. Open aft seat bottoms and verify no gap around foam spacer at aft end of seat bottom structure.
- B. If yielding of steel tube frame(s) OR fuselage has occurred, inspect rotorcraft as follows:
1. Perform Part A inspections.
 2. Visually inspect steel tube frames for yielding. Using 10X magnification, visually inspect frames within 1 inch of welds for cracks. Pay particular attention to aft vertical strut members of lower steel tube structure. Replace cracked or yielded frame(s).

NOTE

No frame yielding is allowed.

3. Visually inspect fuselage, landing gear attach points, and firewalls for buckling or cracks.

NOTE

Vertical firewall attach points for engine mount struts are susceptible to cracks due to hard landings.

4. Visually inspect tailcone for buckling or loose rivets.
5. Visually inspect landing gear skid tube-to-strut attach points for bending and cracks.
6. Hard landings can be accompanied by tail skid strikes, tail rotor strikes, main rotor blade strikes, etc. To inspect for these conditions, refer to the appropriate portion of § 2.500. Minor sheet metal repairs to cabin are permitted. Any cracks, yielding or buckling in steel tube structure or tailcone are cause for replacement. Major defects may be factory-repaired by replacement of parts and assemblies.

Intentionally Blank

| 2.560 [Reserved.]

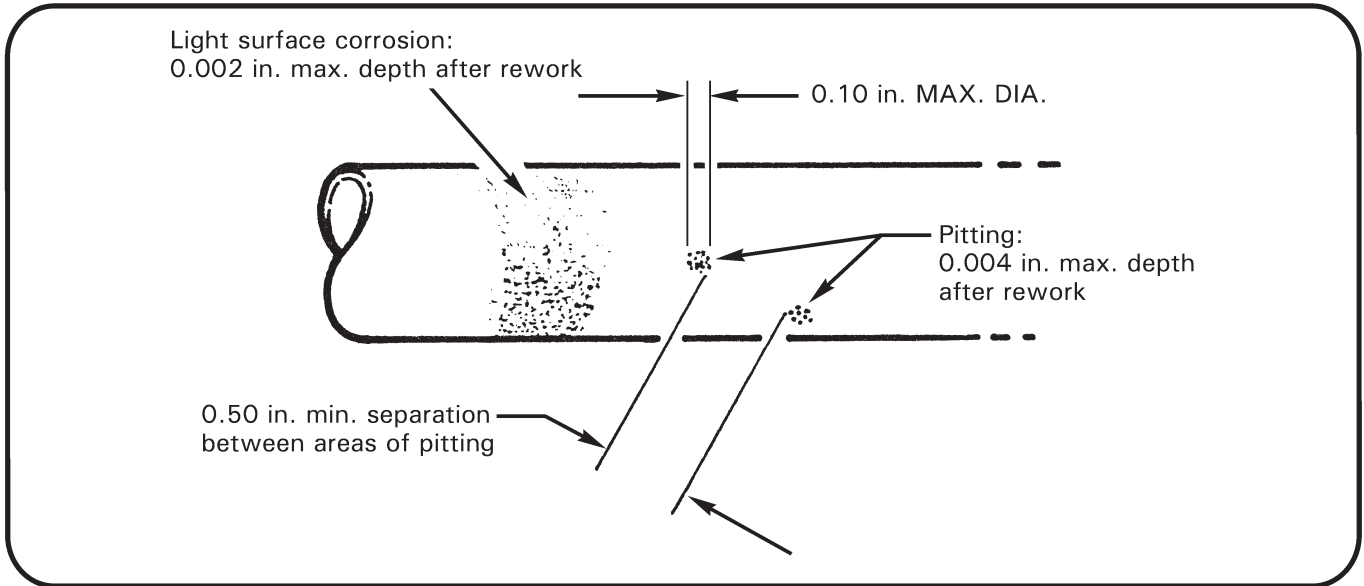

FIGURE 2-16 UPPER FRAME CORROSION REMOVAL LIMITATIONS

2.561 Corrosion on C020 Upper Steel Tube Frame

1. Polish out corrosion on steel frame tube members.
 - a. Polish out light surface corrosion on frame members using Scotchbrite or 400 grit wet-or-dry sandpaper subject to dimensional limitations shown in Figure 2-16.
 - b. Polish out corrosion pitting using 320-grit wet-or-dry sandpaper subject to dimensional limitations shown in Figure 2-16.

NOTE

For large areas of corrosion, it may be necessary to remove entire upper frame from aircraft and strip off paint to adequately determine extent of damage.

2. Prime bare metal with a good quality zinc chromate or epoxy primer.
3. Refinish area with gray epoxy top coat or equivalent.

2.570 Volcanic Ash Recommendations

Flight in visible volcanic ash conditions ("ash cloud") is detrimental to the helicopter and should be avoided. If helicopter has been operated in visible volcanic ash conditions:

1. Refer to Lycoming SI 1530. Wearing suitable protective equipment, use vacuum cleaner followed by compressed air to remove as much debris as possible. Do not use compressed air near main rotor blade drain holes.
2. Refer to applicable Pilot's Operating Handbook (POH) Section 8. Thoroughly clean, wash, and rinse helicopter, including inner circumference of drive belts.
3. Remove main rotor blade tip covers and clean blade tips.
4. Using 10X magnification, visually inspect any exposed main rotor blade skin-to-spar bond line (adhesive) for gaps (empty space between skin and spar). Blade is unairworthy if any gap, including "pin hole(s)", is detected in the bond line. Refinish blade as required.
5. Inspect condition of drive belt sheaves. Replace any sheave having corrosion pitting, flaking, wear thru metalized or anodized coatings, roughness, or sharp ridges. Replace drive belts if either sheave has sharp ridge(s) on drive belt contact surface.
6. Disconnect alternator drive belt from alternator. Spin alternator pulley by hand and verify rotor bearings and brushes operate smoothly; repair alternator as required if roughness or unusual noise is encountered (volcanic ash can enter via unfiltered cooling air). Inspect alternator and ring gear support pulleys and verify no wear steps; replace alternator belt and pulley(s) if wear steps exist. Perform Lycoming SI 1129 alternator belt tension check and adjust as required.
7. Clean air box interior and:
 - a. Inspect air filter and replace as required.
 - b. Inspect induction system downstream of air filter (a clean, white glove is beneficial). If volcanic ash is found then:
 - i. Clean induction system, disassembling as required.
 - ii. Disassemble carburetor or fuel injection servo, as applicable, inspect for internal contamination, and overhaul as required.
 - iii. Perform Lycoming SI 1191 Cylinder Compression check.
 - iv. Perform Lycoming SB 388 Procedure to Determine Exhaust Valve and Guide Condition.
 - v. Inspect spark plug condition; service as required.
 - c. On fuel injected engines, perform Lycoming SI 1275 Cleaning Fuel Injection Nozzles (volcanic ash can enter atomization screens).

2.570 Volcanic Ash Recommendations (continued)

8. Remove each magneto's distributor gear inspection plug and inspect visible internal portion for contamination; overhaul magnetos if volcanic ash is found inside (magneto vent plugs are unfiltered).
9. Inspect engine oil condition. Regardless of oil time-in-service if oil smells bad, is opaque (or is not obviously brown), or if particulates are detectable on the dipstick, change engine oil & oil filter, inspect suction screen and old oil filter, and perform Lycoming SI 1191 Cylinder Compression check if not previously accomplished in step 6.

2.580 Windshield Inspection

This section has been moved to Chapter 27 Doors and Windows.

2.590 Lightning Strike

Lightning strikes are extremely rare for helicopters operating in VFR conditions.

If a lightning strike does occur, RHC recommends performing a 100-hour inspection per § 2.400 and following recommendations for aircraft struck by lightning per Lycoming Service Bulletin No. 401.

High voltage that is well conducted through the aircraft structure will dissipate and cause minimal damage. High voltage that is not well conducted through the aircraft structure can result in excessive heat, which can bake, burn, char, or even melt certain materials. Heat damage may or may not be detectable by visual inspection. A component may not exhibit obvious damage, but temperatures above 300° F can alter the strength of some materials and thus affect a component's service life and airworthiness.

Visually inspect main rotor blades, landing gear, drive train, airframe, and flight controls thoroughly for obvious damage such as electrical arcing or burns, pitting, or cracking. Particular attention should be given to rod ends, journals, etc., where the conductive path is most susceptible. If obvious damage is detected in any of the above-mentioned systems, additional components may require replacement. Contact [RHC Technical Support](#) with detailed documentation for further guidance prior to approving aircraft for return to service.

2.595 C148 Bulkhead Inspection

If C042-1 upper vertical stabilizer, C043-1 lower vertical stabilizer, or C044-1 horizontal stabilizer is dented, cracked, or torn, or if a tail skid strike or tail gearbox breakage has occurred, perform the following:

1. On associated tailcone's C148 bulkhead, strip paint from cross-hatched surfaces shown in Figure 2-18 using § 23-71 approved materials.
2. Perform fluorescent penetrant inspection (FPI) per § 23-42 of stripped surfaces. Replace tailcone if crack is indicated.
3. Conversion coat bare aluminum per § 23-51, as required. Epoxy prime (chromated-epoxy primer preferred) & topcoat stripped surfaces per § 23-60.

NOTE

Do not apply primer or topcoat to tail rotor gearbox attachment surfaces.

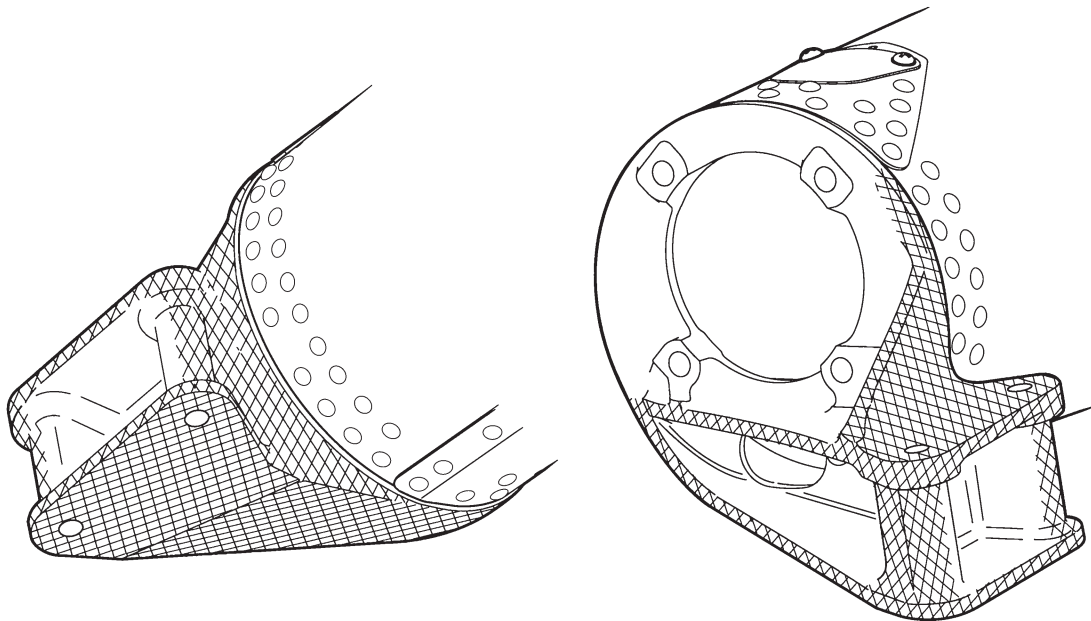

FIGURE 2-18 PENETRANT INSPECT CROSS-HATCHED SURFACES OF C148 BULKHEAD

2.600 2200-Hour/2400-Hour/12-Year Inspection**NOTE**

KI-4402 R44 2200-Hour (2400-Hour for Cadet) Inspection Kit contents and KI-4403 R44 II 2200-Hour Inspection Kit contents are available online at <https://robinsonheli.com> for review.

NOTE

12-Year Inspection is only required for helicopters that have accumulated 12 years calendar time and less than 2200 hours (R44 S/Ns 0001 thru 9999 & R44 II S/Ns 10001 thru 29999) or 2400 hours (R44 Cadet S/Ns 30001 & subsequent) time in service since new, since last 2200-hour/2400-hour inspection, or since last 12-year inspection.

1. Refer to helicopter maintenance records and § 3.300; replace life-limited parts, or next higher assemblies, as required.
2. Refer to helicopter maintenance records and § 1.102; perform additional component maintenance, as required.
3. Remove engine, engine cooling panels, fanwheel, scroll, air induction system, carburetor heat system, oil lines, and all hoses. Overhaul or inspect, as required, magnetos, alternator, and carburetor per appropriate manufacturer's maintenance publications and service bulletins.
4. Remove horizontal, both vertical, & float stabilizers, and F044 mount, as applicable. If replacement is not required, visually inspect condition. Fluorescent penetrant inspect any suspect metal areas per § 23-42. Install stabilizers per §§ 4.500 thru 4.640.
5. Inspect cross tubes per § 5.210. Remove landing gear per § 5.110.
6. Remove steel tube frames per § 4.200, and replace as required. If replacement is not required, proceed per § 1.102 Part A or B, as appropriate. Install frames per § 4.200.
7. Visually inspect cyclic stick for corrosion. If corrosion is evident: remove cyclic stick per § 8.111. Remove wiring harness. Remove paint via dry media blasting. Visually inspect and verify no cracks or corrosion. Magnetic particle inspect per § 23-41. Clean, prime, and paint per § 23-60. Install wiring harness. Install cyclic stick per § 8.111.

2.600 2200-Hour/2400-Hour/12-Year Inspection (continued)

8. For C121 push-pull tube assemblies not addressed in § 1.102: Visually inspect and verify no corrosion. If corrosion is detected, remove push-pull tube, record assembled length, remove rod ends, remove paint, and repair or replace as required. After repair, fluorescent penetrant inspect per § 23-42. Clean, prime, and paint per § 23-60. Install rod ends to previously recorded assembled length. Install push-pull tubes per Chapter 8.
9. Inspect airframe wiring condition. Verify no corrosion, insulation deterioration, or other damage. Verify correct wires attached to correct circuit breakers.
10. Remove main and aux tank fuel bladders per § 12-11 and § 12-21. Visually inspect; verify no cracking or delamination of rubber and rubber-to-metal joints. Visually inspect threaded inserts and fittings for damage. Pressurize to 1 psi max and check for leaks with mild soap & water mixture. Visually inspect tank structures for evidence of bladder leakage. Install bladders per § 12-11 and § 12-21.
11. Perform clutch sheave alignment per § 7.230 and intermediate flex plate shimming per § 7.330.
12. Perform main rotor flight control and blade angle rigging per § 10.110 and § 10.120.
13. Perform tail rotor flight control and blade rigging per § 10.130 and § 10.140.
14. Perform 100-hour/annual inspection per § 2.400.
15. Weigh helicopter per § 1.230.

NOTE

Extended low-power operation with new piston rings may prevent proper piston ring seating.

16. Balance tail rotor per § 10.240. Track and balance main rotor per § 10.230. Perform ground check, run up, and flight checks per §§ 2.205, 2.210, & 2.220.
17. Drain and flush main and tail rotor gearboxes per §§ 1.120 & 1.130.
18. Make appropriate maintenance record entries. Enter maintenance performed (such as part replacement, equipment adjustments, weighing, servicing, and lubrication) and inspection data. Data must include a description of (or reference to data acceptable to the Administrator) the work performed, date, helicopter total time in service, signature, certificate type and certificate number of person approving aircraft return to service.

2.610 Tail Rotor Gearbox 12-Year Maintenance

1. If installed, drain and flush C021-1 tail rotor gearbox assembly per § 1.130 steps 1 thru 11.
2. If installed, remove tail rotor gearbox per § 7.410.
3. Remove hardware securing C116-1 yoke to C545 input gear. Visually inspect yoke and replace yoke if damaged. Visually inspect input gear splines; return gearbox to RHC if splines are damaged, including wear steps. Replace input shaft seal per § 7.450 steps b) thru l).
4. Remove sight gage and clean glass. Visually inspect gear set; return gearbox to RHC if corrosion or other damage is detected. Install sight gage and special torque gage per § 23-33.
5. Replace output shaft seal per § 7.440 steps b) thru g).
6. Install tail rotor gearbox per § 7.420 steps a) thru g).
7. Remove filler-plug. Fill gearbox to center of sight gage using correct gearbox oil (refer to R44 Service Letter SL-73). Rotate rotor system by hand for several revolutions. Check gearbox oil level and adjust as required; install filler-plug and special torque per § 23-33.
8. Connect tail light and chip detector wiring to airframe harness at connectors. Turn battery on. Verify tail light illuminates with position lights turned on. Depress push-to-test TR CHIP button and verify TR CHIP caution light illuminates. Turn battery off.
9. Install tail rotor per § 30-10 Part A or B, as applicable.

2.620 Fanwheel 12-Year Maintenance

1. If installed, remove D174-2 fanwheel assembly per § 6.210.
2. Mark fanwheel assembly parts, including balancing hardware, for identical reassembly.
3. Refer to Figure 2-19. Loosen bolts securing C187-3 cone assembly and C186-1 hub to fanwheel. Verify hub axial play does not exceed 0.020 inch with hub bolts loose and NAS6603 bolts tight.
4. Remove hardware securing cone assembly, hub, and C178-2 spacer(s) to fanwheel and remove parts, noting relative locations for identical reassembly.
5. Visually inspect all components for obvious damage. Verify no elongation of fastener holes. Replace parts as required.
6. Assemble fanwheel wet with approved primer (chromate primer preferred; refer to § 23-75) between all clamping surfaces; while primer is wet, special torque D210 nuts per § 23-33. Apply B270-21 protectant to threads and tip of B660-1 bolts, if installed.

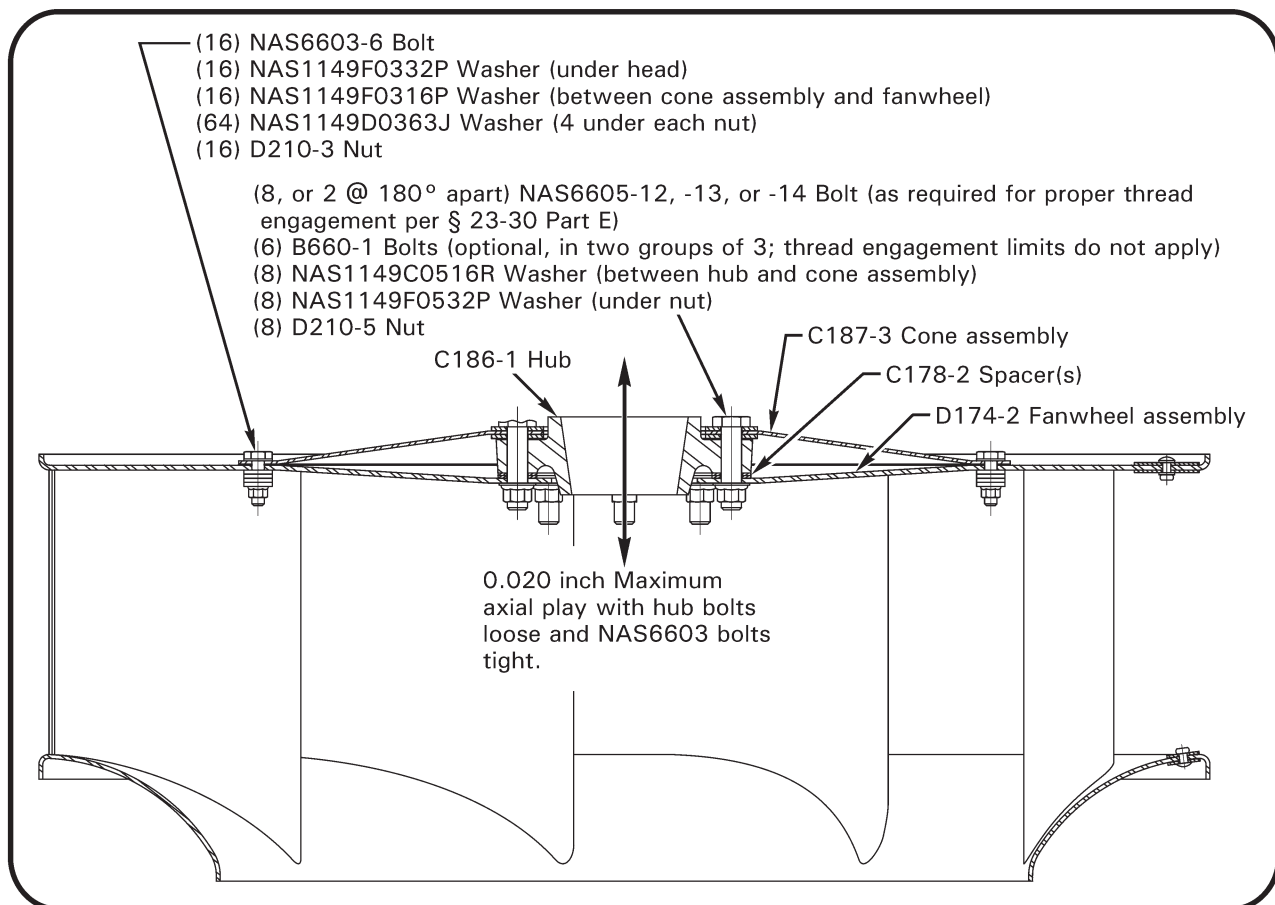

FIGURE 2-19 D174-2 FANWHEEL ASSEMBLY

2.630 C258-5 & -8 Main Rotor Pitch Link Assembly Inspection

1. Temporarily mark each pitch link and associated swashplate ear with unique identifiers, such as different colors and/or X & O. Measure and record overall lengths of both links.
2. Remove pitch links.
3. R44 Service Letters SL-58 and SL-95 refer. Disassemble pitch links, keeping parts from each link separate from the other.
4. Evaluate rod ends per § 2.122 and replace as required.
5. Visually inspect parts with 10X magnification for obvious damage. Replace damaged parts.
6. Visually inspect interior of barrels with borescope for obvious damage. Replace damaged barrels.
7. Apply a light coat of A257-2 or -22 oil to rod end threads and assemble pitch links; adjust to recorded lengths. Torque jam nut & adjacent stamped nut per § 23-32. Special torque self-locking 21FKF-813 or 27FKF-813 jam nut per § 23-33.
8. Install pitch links to associated swashplate ear and, if installed, main rotor blade. Torque fasteners per § 23-32 and torque stripe per Figure 2-1.

2.640 Swashplate Assembly 12-Year Inspection

1. Remove swashplate assembly per § 8.411.
2. Remove both pitch links and upper A205-7 fork assembly from swashplate.
3.
 - a. If swashplate is P/N C017-6 Rev AD or subsequent, proceed to step 4.
 - b. If swashplate is P/N C017-4, or is P/N C017-6 Rev AA, AB, or AC, AND
 - “B900-13 MOD” is marked adjacent to swashplate data plate, proceed to step 4.
 - “B900-13 MOD” is NOT marked adjacent to swashplate data plate, perform R44 Service Letter SL-76A.
4. Refer to Figure 1-2B. Remove (10) NAS1352 screws (with washers) securing C206-2 & C200-3 retainers to upper swashplate. Remove both retainers and C219-3 spacer and set aside.
5. Remove inner screws securing sleeve to lower swashplate. Remove sleeve, shims, and ball and set aside.
6. Using a 0.006 inch feeler gage, gently pry up outer edge of upper C217-1 seal and expose top ball bearing. Discard upper seal.
7. Clean all parts, including C203-5 yokes.
8. Visually inspect cleaned parts with 10X magnification, to include blind screw-holes in upper & lower swashplates, for obvious damage. Replace swashplate assembly if damage is detected on either upper or lower swashplate. Replace damaged parts.
9. Perform swashplate tilting friction adjustment per § 8.413 step 4.
10. Lubricate swashplate bearings per § 1.195 steps 7 thru 11. Install new upper seal during procedure.
11. Remove rod end from upper fork. Using non-metallic tools, remove majority of sealant in threaded hole of fork. Visually inspect parts with 10X magnification for obvious damage. Replace damaged parts. Assemble upper fork assembly and adjust pivots' center-to-center dimension to 3.85 ± 0.03 inches. Standard torque jam nut & palnut per § 23-32 and torque stripe per Figure 2-1. Fill exposed cavity with B270-13 sealant.
12. Remove lower A205-7 fork assembly from non-rotating scissors and clean. Remove rod end from lower fork. Visually inspect parts with 10X magnification for obvious damage. Replace damaged parts. Assemble lower fork assembly and adjust pivots' center-to-center dimension to 3.70 ± 0.03 inches. Standard torque jam nut & palnut per § 23-32 and torque stripe per Figure 2-1. Install lower fork on C204-2 arm and standard torque bolt per § 23-32. Install palnut, standard torque per § 23-32, and torque stripe per Figure 2-1.
13. Install swashplate assembly per § 8.412.

2.650 Landing Gear Assembly Inspection

A. 12 Year Inspection

1. Remove left skid tube, and remove rain cap and skid extension from tube.
2. Remove fasteners securing struts to cross tubes. Using a twisting motion, remove left struts from cross tubes.
3. Remove right skid tube, and remove rain cap and skid extension from tube.
4. Using a twisting motion, remove right struts from cross tubes.
5. Clean cross tubes, struts, and skid tubes.
6. Visually inspect interior of struts with borescope (or similar) for obvious damage. Visually inspect exterior of struts using minimum 3X magnification for obvious damage. Any corrosion on, or adjacent to, a weld requires corrosion & paint removal followed by MPI. Upon favorable MPI results, apply § 23-76 powder coat.
7. Refer to § 5.300. Visually inspect interior of skid tube with borescope (or similar). Visually inspect exterior of parts using minimum 3X magnification. As required, touch-up coatings with § 23-75 primers and § 23-77 paints.
8. Visually inspect interior of cross tubes with borescope (or similar) for obvious damage. Visually inspect exterior of cross tubes using minimum 3X magnification for obvious damage. As required, touch-up coatings with § 23-75 primers and § 23-77 paints.
9. Assemble landing gear.
10. Install landing gear per § 5.120.

B. 2200-Hour/2400-Hour Inspection

1. Remove left skid tube, and remove rain cap and skid extension from tube.
2. Remove fasteners securing struts to cross tubes. Using a twisting motion, remove left struts from cross tubes.
3. Remove right skid tube, and remove rain cap and skid extension from tube.
4. Using a twisting motion, remove right struts from cross tubes.
5. Remove exterior paint from cross tubes, struts, and skid tubes.
6. Magnetic particle inspect steel struts and fluorescent penetrant inspect aluminum cross tubes, elbows, and skid tubes per §§ 23-41 and 23-42. Clean, prime, and paint per § 23-60.
7. Assemble landing gear.
8. Install landing gear per § 5.120.

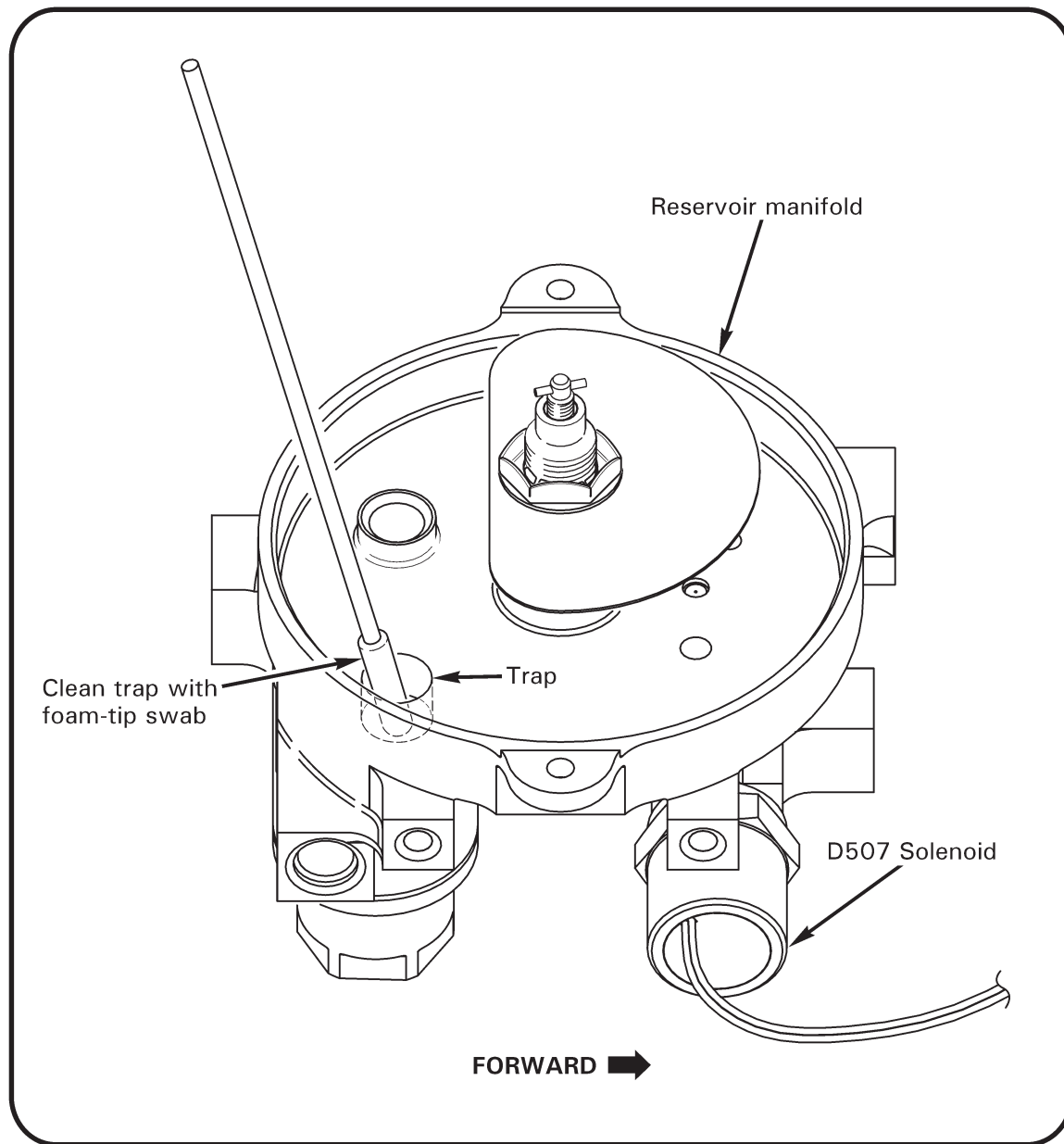

FIGURE 2-20 HYDRAULIC RESERVOIR INSPECTION

2.660 Hydraulic Reservoir 12-Year Inspection

1. Remove reservoir filler-vent.
2. Place a one-liter container beneath D500-1 hydraulic pump. Remove caps from pump suction and pressure T-fittings. Allow fluid to drain thru suction hose into container. Loose filter cap, allow fluid in pressure hose to drain, then tighten filter cap.
3. Remove and retain both NAS6603-3 bolts & hardware securing D486-1 (finned) housing to lower, manifold portion of D211 reservoir.

2.660 Hydraulic Reservoir 12-Year Inspection (continued)

4. Lift off D486-1 housing from manifold (there will be some resistance due to o-ring packing).
5. Refer to Figure 2-20. Avoid disturbing orientation of sheet-metal baffle. Suction remaining fluid from manifold using suitable, clean, plastic tube (do not use metal tool). Using lint-free wipe, clean exposed interior of manifold. Wipe out any residue from trap (blind hole) with clean, foam-tip swab.
6. Inspect interior of manifold for corrosion. Replace reservoir assembly if corrosion is detected.
7. Using lint-free wipe, clean interior of D486-1 housing and visually inspect. Replace housing if corrosion is evident.
8. Lubricate new MS28775-240 o-ring packing with A257-15 fluid and install in groove at base of D486-1 housing.
9. Install D486-1 housing on manifold, align sight gage with bolt hole adjacent solenoid, and fully seat housing by hand. Install NAS6603-3 bolts & hardware and standard torque.
10. Coat housing-to-manifold circumferential juncture with B270-21 protectant.
11. Drain and flush hydraulic system per § 1.180.