

**CHAPTER 10**

**RIGGING, TRACK AND BALANCE**

<u>Section</u>	<u>Title</u>	<u>Page</u>
10.000	Rigging, Track and Balance . . . . .	10.1
10.001	Introduction . . . . .	10.1
10.002	Rod End Adjustment Procedure . . . . .	10.1
10.100	Rigging . . . . .	10.2
10.110	Main Rotor Flight Controls . . . . .	10.2
10.111	Cyclic Controls . . . . .	10.2
10.112	Swashplate . . . . .	10.4
10.113	Collective Control . . . . .	10.4
10.120	Main Rotor . . . . .	10.4
10.121	Cyclic Travel Rigging . . . . .	10.7
10.122	Collective Travel Rigging . . . . .	10.10
10.130	Tail Rotor Flight Controls . . . . .	10.11
10.131	Pedals . . . . .	10.11
10.132	C316 Bellcrank . . . . .	10.12
10.133	A120-3 Bellcrank . . . . .	10.12
10.134	Tail Rotor Pitch Links . . . . .	10.12
10.140	Tail Rotor Rigging . . . . .	10.12
10.150	Throttle Correlation Rigging . . . . .	10.19
10.160	Actuator Rigging . . . . .	10.19
10.200	Track and Balance . . . . .	10.19
10.210	Equipment Requirements . . . . .	10.20
10.220	Equipment Installation . . . . .	10.20
10.221	Main Rotor Equipment Installation . . . . .	10.20
10.222	Tail Rotor Equipment Installation . . . . .	10.24
10.230	Main Rotor Track and Balance Procedure . . . . .	10.29
10.231	Main Rotor Balance Adjustment . . . . .	10.31
10.232	Main Rotor Pitch Link Adjustment . . . . .	10.31B
10.233	Main Rotor Trim Tab Adjustment . . . . .	10.39
10.234	Main Rotor Track and Balance Troubleshooting . . . . .	10.40
10.240	Tail Rotor Balance Procedure . . . . .	10.42
10.250	Autorotational RPM Adjustment . . . . .	10.47

Intentionally Blank

**CHAPTER 10****RIGGING, TRACK AND BALANCE**10.000 Rigging, Track and Balance10.001 Introduction

This section contains procedures necessary to rig the main rotor flight controls, tail rotor flight controls and throttle correlation. The track and balance procedures in this section are to be used in conjunction with Chadwick-Helmuth balancing equipment instructions.

**WARNING**

**A rotor which is smooth after balancing but then goes out of balance again within a few flights is suspect and must be examined by a RHC-authorized component overhaul facility before further flight.**

10.002 Rod End Adjustment Procedures

Refer to § 23-34 Push-Pull Rod End Adjustment.

10.100 Rigging

10.110 Main Rotor Flight Controls

10.111 Cyclic Controls

The cyclic control travel is non-adjustable and is controlled by the A211-3 stop plate attached to cyclic box assembly.

<b>NOTE</b>			
The following push-pull tube assemblies and fork assembly between the keel panels are to be adjusted to the noted center-to-center dimensions:			
C121-1	=	51.03	± 0.03 inches
C121-3	=	32.54	± 0.03 inches
C121-19	=	31.38	± 0.03 inches
A205-3, -5	=	03.80	± 0.03 inches

- a. Refer to Figure 10-1. Place cyclic control in neutral position. Cyclic neutral position is 7.0 inches to the right of full-left travel and at mid-point of total fore and aft travel or use MT559-1 rigging blocks. Place collective control full down.
- b. Apply full cyclic and collective friction.

<b>NOTE</b>	
Care must be taken not to move cyclic control from neutral position.	

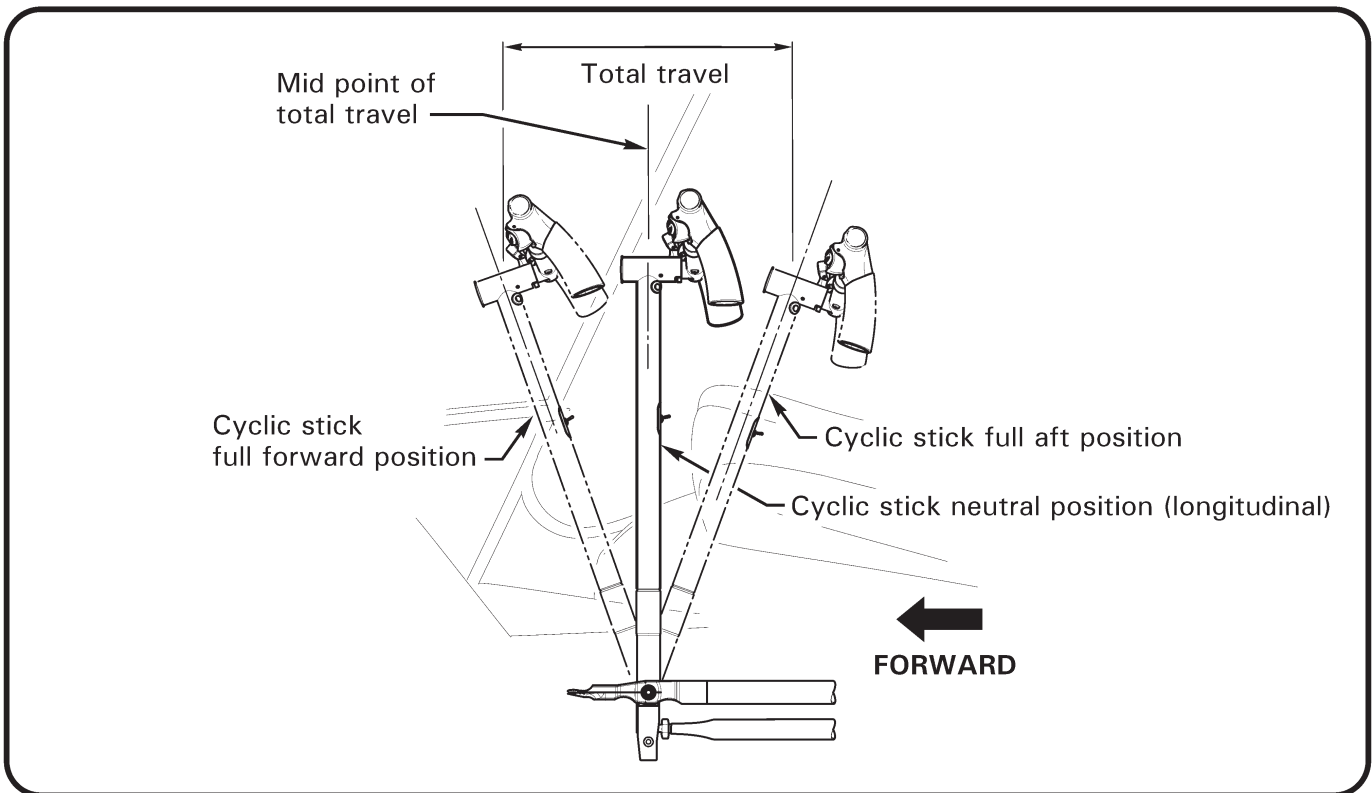
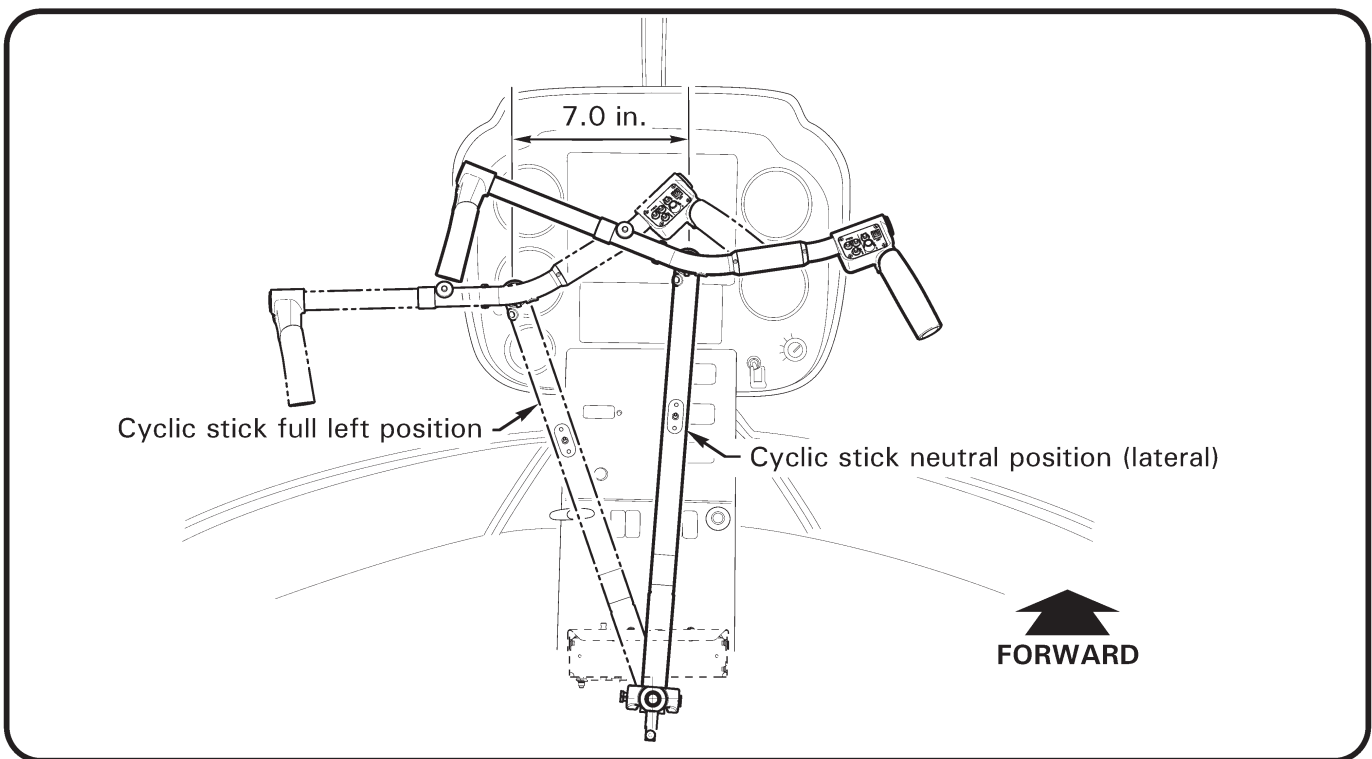

FIGURE 10-1 CYCLIC STICK NEUTRAL POSITION

### 10.112 Swashplate

1. With cyclic and collective controls locked in position per § 10.111, adjust C121-31 (or C121-25) push-pull tubes to obtain a constant clearance from flange of C281-1 fitting per Figure 10-2. A pair of swashplate rigging blocks may be used as a spacer to set the required clearance.
2. Pressurize hydraulics per § 1.190 steps 1 thru 3 and re-check clearance as required, adjust push-pull tubes to meet required clearance.

### 10.113 Collective Control

Since the collective slider stop is non-adjustable, this check is to ensure full control travel is obtained and does not interfere with the swashplate travel.

1. Lift the swashplate boot so the ball and slider tube may be observed.
2. With hydraulics pressurized per § 1.190 steps 1 thru 3, raise collective control full up. Swashplate ball must be flush with top of slider tube within 0.03 inch. If ball is not flush with top of tube, lengthen or shorten C121-31 (or C121-25) push pull tubes equally as required to raise or lower swashplate & ball.

### 10.120 Main Rotor

The main rotor is rigged by determining the average blade angle. Blade angle measurements are taken at the 0.75 radius of the main rotor (or 49.5 inches in from the blade tip).

The main rotor blade angles are measured using the MT525-1 rigging fixture and a Kell-Strom KS113 propeller protractor or a comparable protractor (see Figure 10-4). Use the following procedure to set up for rigging:

1. Initially, adjust both pitch links to 7.54 inches length between rod end centers.
2. Verify that the A205-7 forks at the swashplate are set to the proper length (see Figure 10-3). Measuring to bolt center lines, the lower fork assembly should be  $3.70 \pm 0.03$  inches and the upper fork assembly should be  $3.85 \pm 0.03$  inches.
3. Level the rotorcraft per § 1.220 (Method 2, Main Rotor Hub).
4. Place a tracking stick at the end of one rotor blade and mark the height of the blade tip. Rotate the rotor  $180^\circ$  and mark the height of the opposite blade tip. Teeter the main rotor as necessary to obtain a main rotor track of  $\pm 1$  inch.
5. Zero the propeller protractor to the main rotor hub at the location marked "Level Here". The protractor must be placed parallel to the teeter hinge bolt.
6. Pressurize hydraulics per § 1.190 steps 1 thru 3.

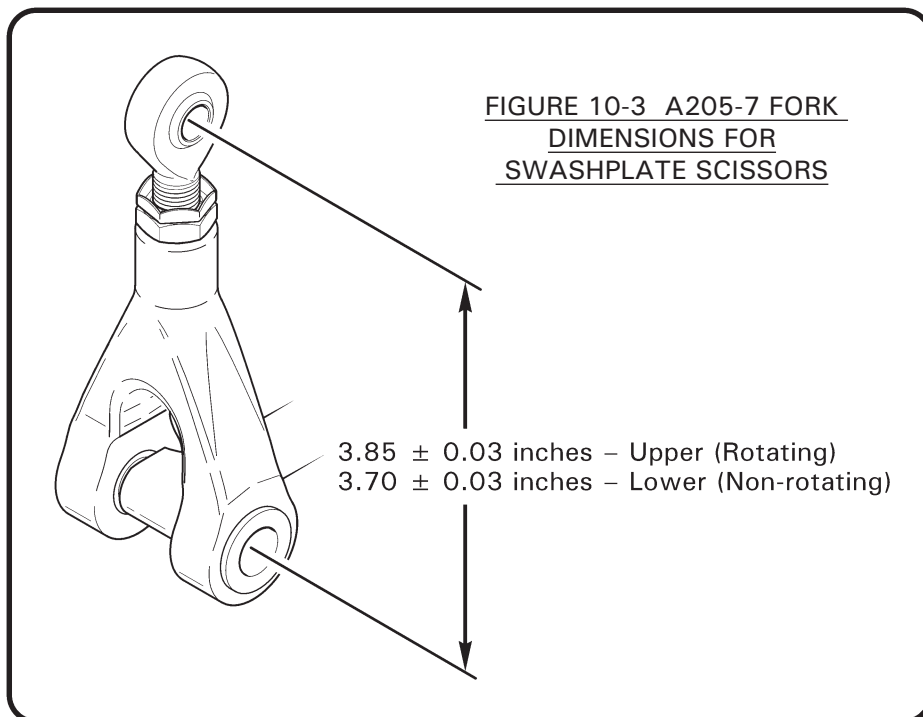
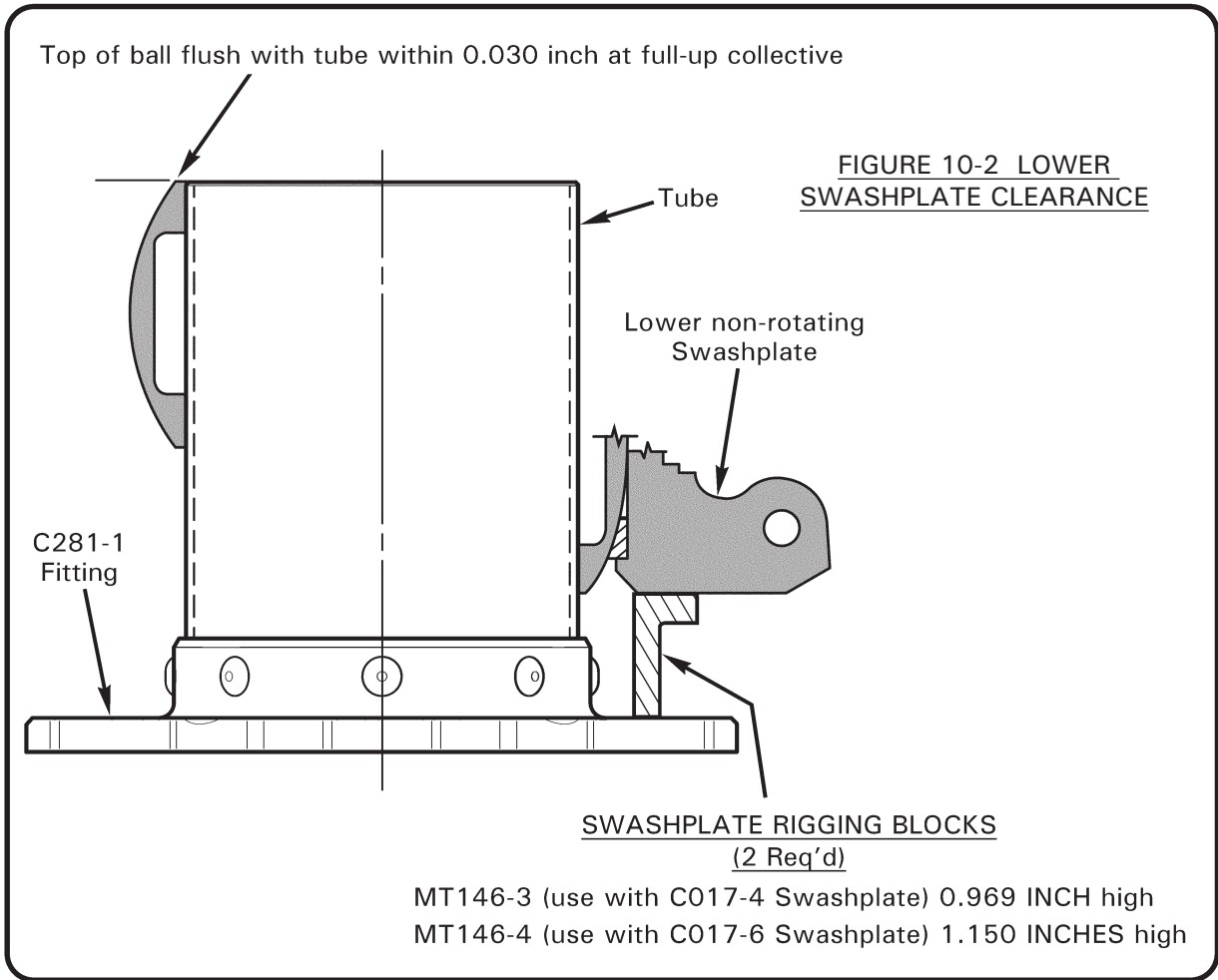

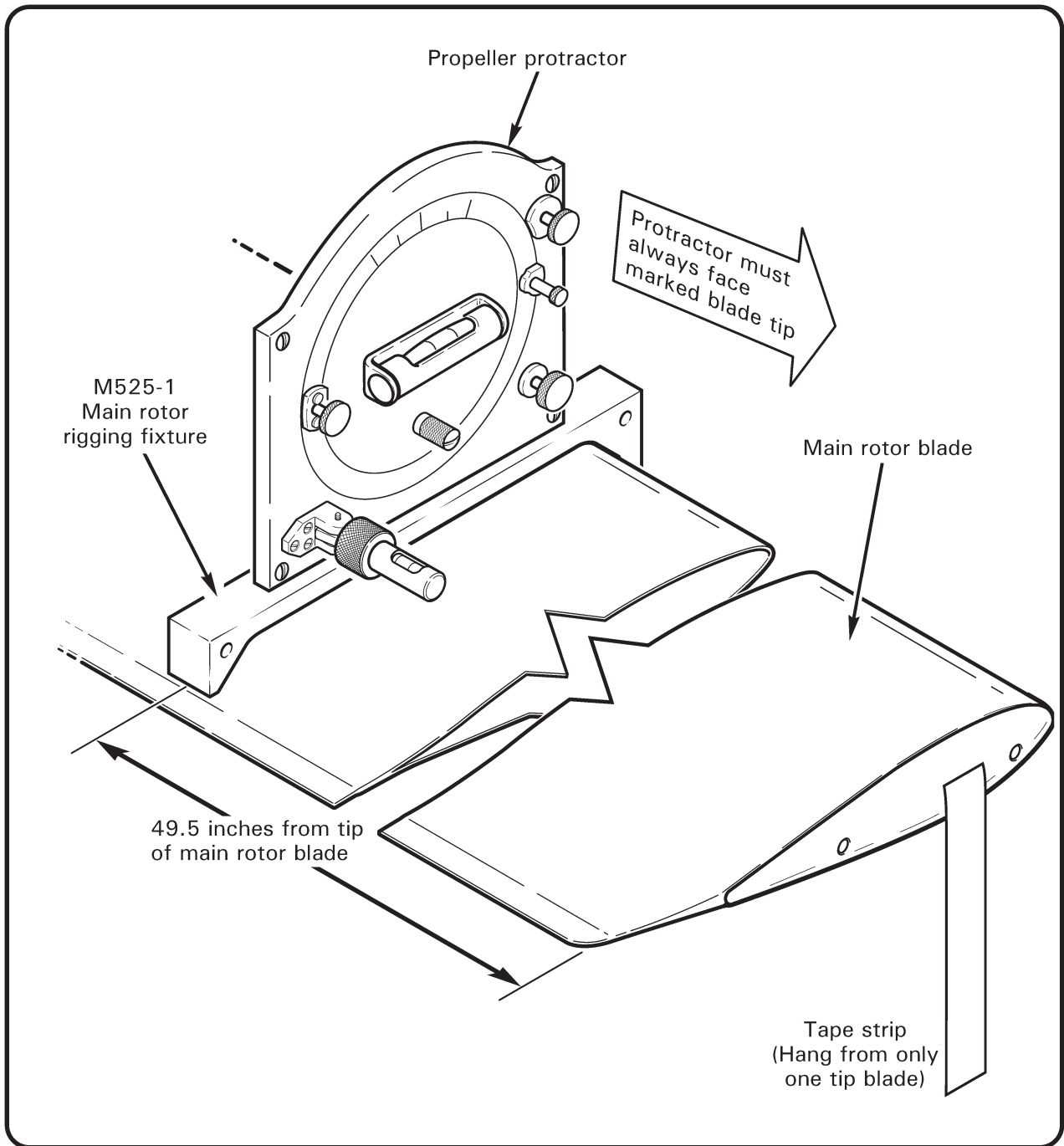

**FIGURE 10-4 PLACEMENT OF PROTRACTOR**

10.120 Main Rotor (cont'd)

## NOTE

When zeroing the protractor, the face or dial should remain facing one of the rotor blades. Mark this blade with a piece of tape. When making blade angle readings, the face or dial of the protractor must always face the marked blade.

- e) Measure in from the tip of each main rotor blade 49.5 inches and place a piece of 1-inch masking tape chordwise across each blade with the center of the tape over the mark.

## WARNING

**Do not mark the rotor blades with a ball point pen or other sharp instrument. Use a grease pencil or soft marker. Sharp instruments can scratch the blades skins, causing cracks and fatigue failure of the blade.**

- f) Mark each rotor blade with a different color designation such as red or blue. This will be used in recording blade angles.

10.121 Cyclic Travel Rigging

## NOTE

Adjust collective travel rigging before cyclic travel rigging. Hydraulic flight controls must be pressurized prior to measuring blade angles.

- a) Place the collective control full down. Place the cyclic control in the neutral position laterally (7.0 inches to the right of full left travel) and hold against the forward stop.

## NOTE

Sand bags may be used to secure cyclic stick against stops to ensure it will not move.

- b) Rotate the blades so the pitch links are aligned with the longitudinal axis of the helicopter. Place the tracking stick at one of the blade tips for reference when rotating the rotor.

10.121 Cyclic Travel Rigging (cont'd)

c) Forward longitudinal cyclic:

- 1) Measure the blade angles and record below. Rotate the rotor 180° and record the blade angles below.

<u>Blue Blade Position</u>		<u>Cyclic Full Forward</u>
Pitch horn aft		_____° nose up
Pitch horn forward	+	_____° nose down
		_____° ÷ 2 = _____°
		(14.25/13.50 degrees required)

<u>Red Blade Position</u>		<u>Cyclic Full Forward</u>
Pitch horn aft		_____° nose up
Pitch horn forward	+	_____° nose down
		_____° ÷ 2 = _____°
		(14.25/13.50 degrees required)

- 2) Adjust the aft swashplate push-pull tube as required (one full turn = 0.44°) to obtain blade angle averages between 13.50° and 14.25°. Additional coarse adjustment is available by simultaneously adjusting the two forward push-pull tubes but they both must be adjusted exactly the same amount.

d) Aft longitudinal cyclic:

- 1) Place the cyclic control in the neutral position laterally and hold against the aft stop.
- 2) Measure the blade angles and record below. Rotate the rotor 180° and record the blade angles below.

<u>Blue Blade Position</u>		<u>Cyclic Full Aft</u>
Pitch horn aft		_____° nose down
Pitch horn forward	+	_____° nose up
		_____° ÷ 2 = _____°
		(14.25/13.50 degrees required)

<u>Red Blade Position</u>		<u>Cyclic Full Aft</u>
Pitch horn aft		_____° nose down
Pitch horn forward	+	_____° nose up
		_____° ÷ 2 = _____°
		(14.25/13.50 degrees required)

10.121 Cyclic Travel Rigging (cont'd)

- 3) Adjust the aft swashplate push-pull tube as required (one full turn = 0.44°) to obtain blade angle averages between 13.50° and 14.25°. Additional coarse adjustment is available by simultaneously adjusting the two forward push-pull tubes, but they both must be adjusted exactly the same amount.

**NOTE**

If adjustment is required to obtain aft cyclic control blade angles, the forward cyclic must be rechecked.

e) Left Lateral Cyclic:

- 1) Place the cyclic control in the neutral position longitudinally (mid travel) and hold the cyclic against the left stop.
- 2) Rotate the rotor until the pitch links are aligned with the lateral axis of the helicopter. Place the tracking stick at the end of one blade for reference.
- 3) Measure the blade angles and record below. Rotate the rotor 180° and record the blade angles below:

<u>Blue Blade Position</u>	<u>Cyclic Full Left</u>	
Pitch horn right	_____	nose up
Pitch horn left	+ _____	nose down
	= _____	÷ 2 = _____ ° Average (8.5/7.5 degrees required)

<u>Red Blade Position</u>	<u>Cyclic Full Left</u>	
Pitch horn right	_____	nose up
Pitch horn left	+ _____	nose down
	= _____	÷ 2 = _____ ° Average (8.5/7.5 degrees required)

- 4) Adjust either of the two forward push-pull tubes as required (one full turn = 0.6 degree) to obtain blade angle averages between 7.5° and 8.5°.

f) Right lateral cyclic:

- 1) Place the cyclic control in the neutral position longitudinally (mid travel) and hold the cyclic against the right stop.

10.121 Cyclic Travel Rigging (cont'd)

- 2) Measure the blade angles and record below. Rotate the rotor 180° and record the blade angles below:

<u>Blue Blade Position</u>	<u>Cyclic Full Right</u>	
Pitch horn right	_____	nose down
Pitch horn left	+ _____	nose up
	= _____	÷ 2 = _____ ° Average
		(7.0/6.0 degrees required)

<u>Red Blade Position</u>	<u>Cyclic Full Right</u>	
Pitch horn right	_____	nose down
Pitch horn left	+ _____	nose up
	= _____	÷ 2 = _____ ° Average
		(7.0/6.0 degrees required)

- 3) Adjust either of the two forward push-pull tubes as required (one full turn = 0.6 degree) to obtain blade angle averages between 6.0° and 7.0°.

**NOTE**

If adjustment is required to obtain right cyclic control blade angles, the left cyclic must be rechecked.

10.122 Collective Travel Rigging

- a) Place the cyclic control in the neutral position (see Figure 10-1). Place the collective control full down. Apply full cyclic and collective friction.
- b) Rotate the main rotor to align pitch links with the longitudinal axis of the helicopter. Place the tracking stick at the end of one blade for reference.
- c) Measure the blade angles using the MT525-1 rigging fixture and propeller protractor.

10.122 Collective Travel Rigging (cont'd)

**NOTE**

The MT525-1 fixture is placed on top of the blade at 49.5 inches from blade tip. The fixture must be held tightly against the leading edge to ensure accurate readings. All measurements must be taken with protractor facing marked blade.

Record blade angles, then rotate rotor 180° and again record angles. Adjust the pitch link of each blade until the two blade angles are within 0.2 degrees of each other when the blade pitch horn is in the forward position. Check the blade angles with each blade pitch horn aft. Average of these angles must be within 0.2 degrees also.

COLLECTIVE FULL DOWN

	<u>Blue Blade</u>	<u>Red Blade</u>
Pitch horn forward	_____ ° nose up	_____ ° nose up
Pitch horn aft	+ _____ ° nose up	+ _____ ° nose up
	_____ ° ÷ 2 = _____ °	_____ ° ÷ 2 = _____ °

(1.0/2.0 degrees required)

- d) Raise collective control to the full up position. Apply full collective friction. Measure the blade angles per Step c) above and record averages below.

	<u>Blue Blade</u>	<u>Red Blade</u>
Pitch horn forward	_____ ° nose up	_____ ° nose up
Pitch horn aft	+ _____ ° nose up	+ _____ ° nose up
	_____ ° ÷ 2 = _____ °	_____ ° ÷ 2 = _____ °

(Average 12.5°/13.5° degrees above collective-down required for rigging; autorotation rpm adjustment will determine final angle)

- e) Track and balance main rotor per Section 10.200.

10.130 Tail Rotor Flight Controls

10.131 Pedals (See Figure 10-5)

Pedal rigging is accomplished as follows:

- a) Insert a 3/16-inch diameter rigging pin through the hole in the right-hand keel panel and the rigging pin holes in the C317-1 bellcrank.
- b) Adjust the C121-9 push-pull tubes as required to obtain a dimension of 2.90 ± 0.03 inches from the pedal to the right hand stop located on the side of the forward console (does not apply to helicopters without stop on lower console).

10.132 C316 Bellcrank (See Figure 10-5)

Remove rigging pin and place left pedal against its stop. Adjust C343-1 push-pull tube to obtain 0.10 - 0.20 inches between C316-1 rod end and bulkhead (0.3 - 0.5 for helicopters without pedal stop on lower console).

10.133 A120-3 Bellcrank

With left pedal at stop, adjust the C121-17 push-pull tube length as required to obtain  $0.35 \pm 0.03$  inch between two faces of pitch control assembly and the housing. (See Figure 10-7).

10.134 Tail Rotor Pitch Links

Adjust the pitch links to a dimension of  $2.620 \pm 0.010$  inches between rod end centers (see Section 8.570).

10.140 Tail Rotor Rigging

- 1) Set up:
  - a) Level the rotorcraft per Section 1.220 (Method 2, Main Rotor Hub).
  - b) Rotate the tail rotor until the blades are parallel to the tailcone.
  - c) Tape a tracking stick to the tailcone at the tip of the fwd blade.

**NOTE**

A tracking stick can be made using a 1" x 12" strip of aluminum with a 90° bend 2 inches from one end.

- d) Visually align the tail rotor to a zero teeter position and mark the tracking stick where the tip of the tail rotor blade passes.
- e) Rotate the tail rotor 180°, using the forward flex coupling so teeter angle is not disturbed, until the opposite blade tip is aligned with tracking stick. Mark the stick.
- f) Teeter the tail rotor to position the blade tip to the mid point between the marks. Rotate the tail rotor and check that the blades track. Repeat the above procedure as necessary to track the tail rotor.
- g) Place the left pedal against its stop. Mark the tracking stick where the blade tip passes the stick. Place the right pedal against its stop and mark the tracking stick.

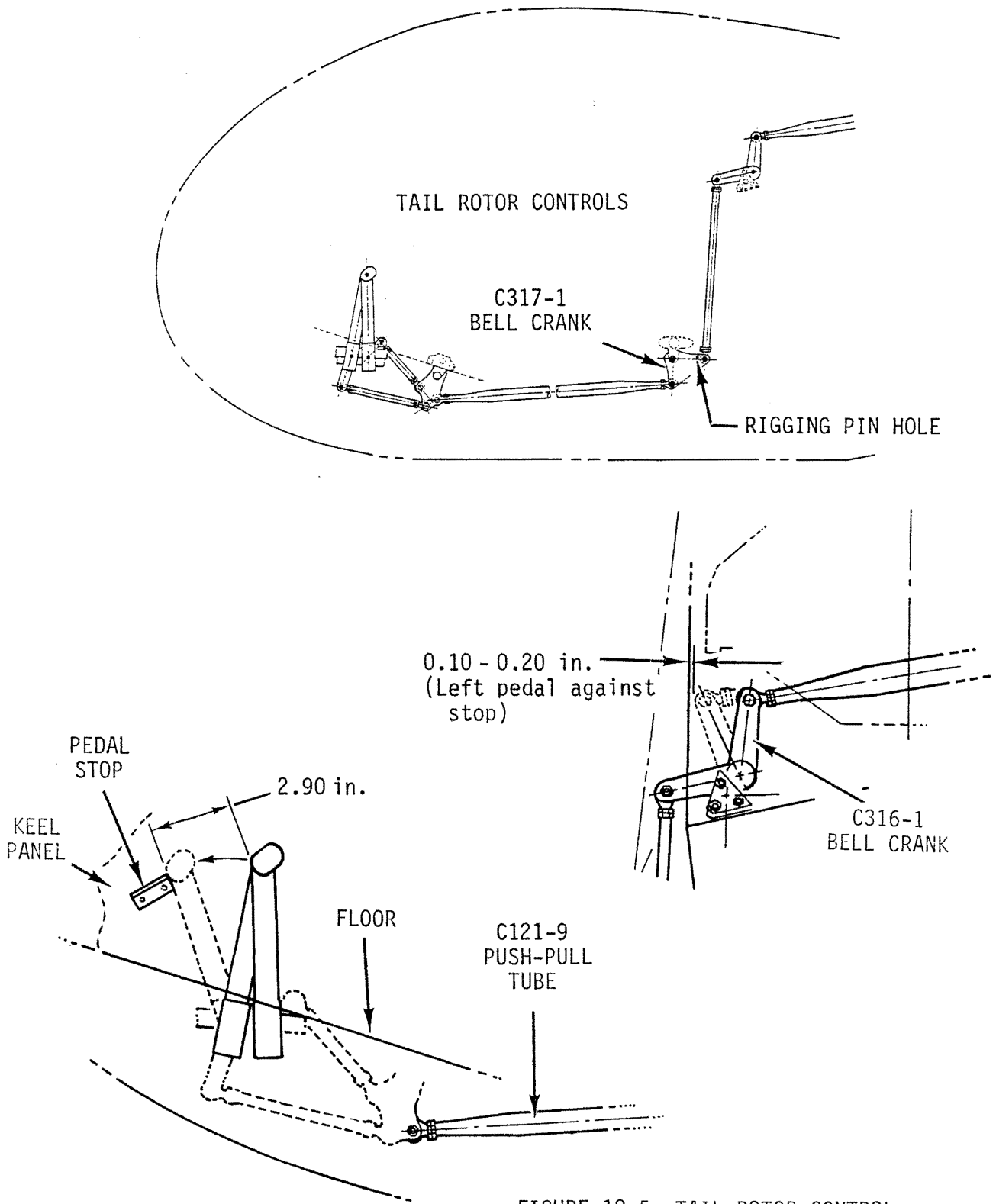

FIGURE 10-5 TAIL ROTOR CONTROL PEDAL RIGGING

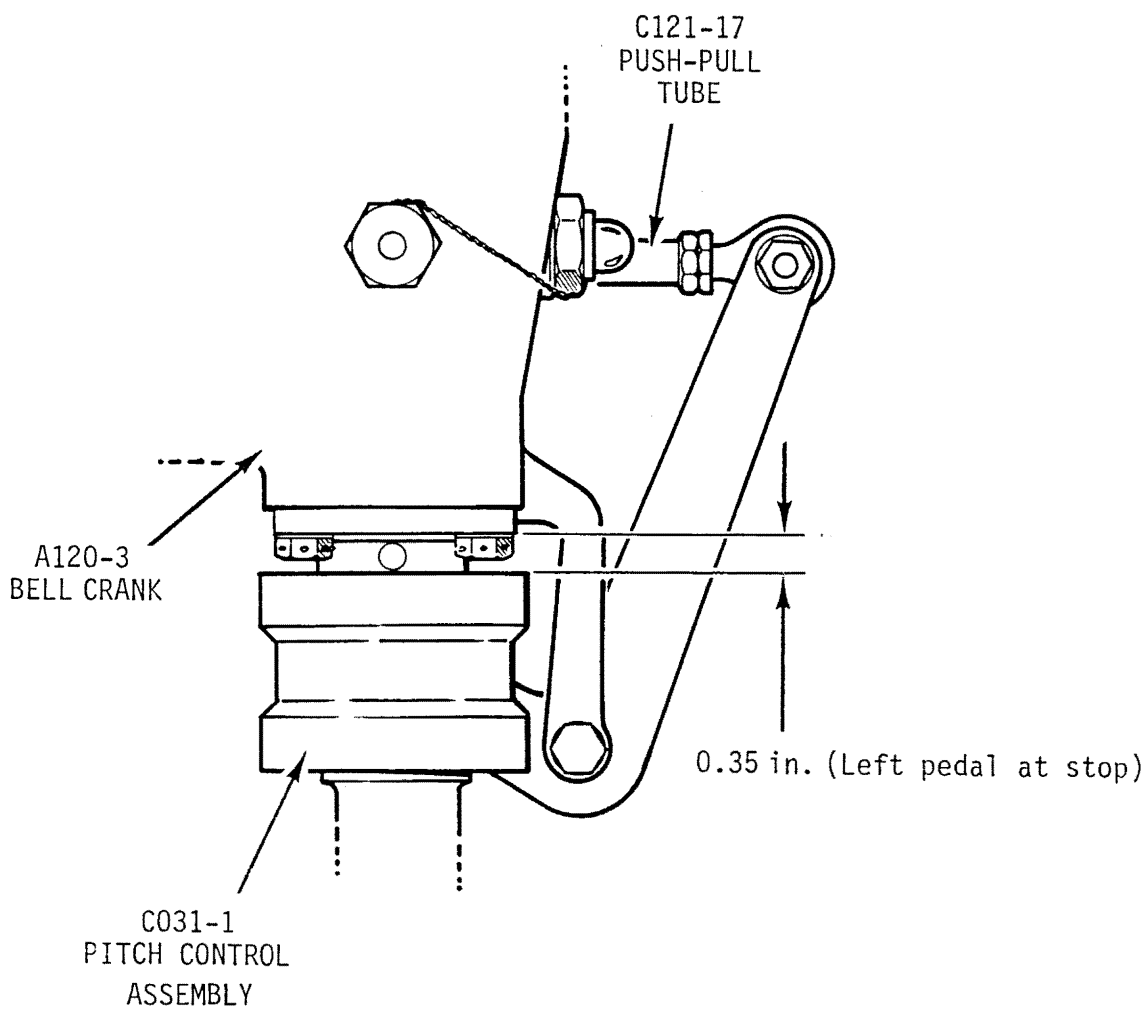
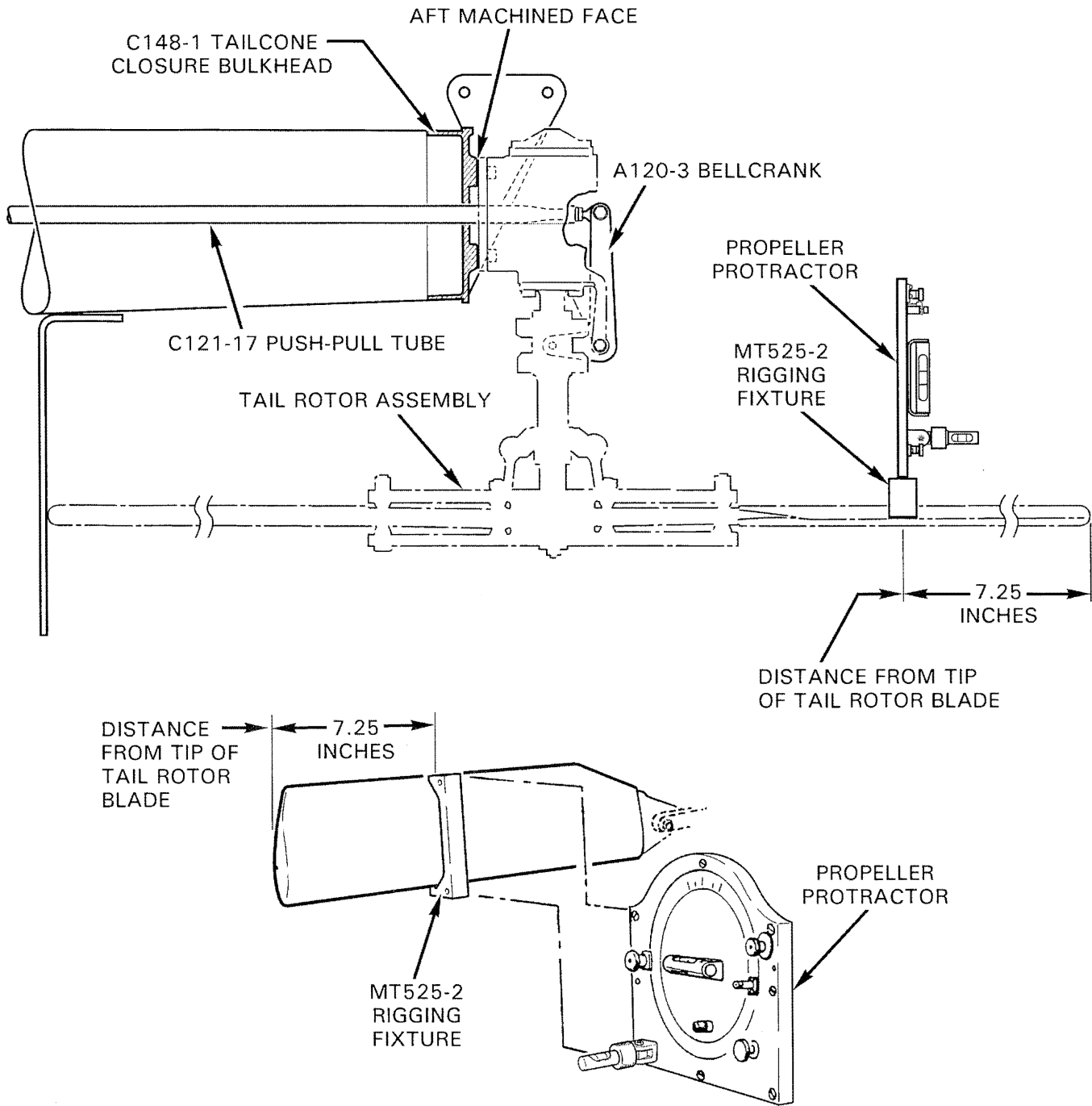

FIGURE 10-6 A120-3 BELL CRANK RIGGING



**FIGURE 10-7 TAIL ROTOR RIGGING**

10.140 Tail Rotor Rigging (cont'd)

2) Measure the tail rotor blade angles as follows:

- a) Using a soft marker or grease pencil mark each blade as red or blue.
- b) Measure in from each blade tip 7.25 inches and place 3/4 inch masking tape chordwise on each blade at this point.
- c) Have someone hold one blade tip at left pedal track mark with left pedal against its stop.
- d) Place MT525-2 rigging fixture on aft blade inboard side.

**NOTE**

MT525-2 fixture must straddle masking tape.

- e) Using a propeller protractor measure blade angle and record below. Rotate tail rotor 180 degrees and record opposite blade angle.

Pedals Full Left

Blue Blade \_\_\_\_\_ ° nose right

Red Blade + \_\_\_\_\_ ° nose right

\_\_\_\_\_ ° ÷ 2 = \_\_\_\_\_  
(18.5/19.0 degrees required)

**CAUTION**

For acceptable track, differences between Blue and Red blade angles must not exceed 0.4 degree. If blade angles cannot be adjusted to within 0.4 degree of each other using adjustable pitch links then remove tail rotor assembly and rotate it one-half revolution, reinstall and repeat above procedure. If blade angles still cannot be adjusted to within 0.4 degree of each other then replace blade(s). Contact factory for blade matching assistance.

**NOTE**

Adjustable pitch link jam nuts must be tight to ensure accurate blade angle measurements.

10.140 Tail Rotor Rigging (cont'd)

**WARNING**

Both pitch links must be same part number (same type and material). Mixing one-piece with adjustable-length pitch links is prohibited. Mixing steel one-piece with aluminum one-piece pitch links is prohibited.

- f. Adjustment of blade angles is made using rod ends of C121-17 push-pull tube. One full turn of rod end will change blade angles 0.33 degrees. Adjust rod end as necessary to obtain 18.5 to 19.0 degrees.
- g. Place right pedal against its stop. Measure blade angles and record below using right pedal track mark.

Pedals Full Right

Blue Blade \_\_\_\_\_ ° nose left

Red Blade + \_\_\_\_\_ ° nose left

\_\_\_\_\_ ° ÷ 2 = \_\_\_\_\_  
 (15.5/16.5 degrees required)

- h. Adjust C121-17 push-pull tube as necessary to obtain blade angles of 15.5 to 16.5 degrees.

**NOTE**

If adjustment is required to obtain right pedal blade angles, left pedal angles must be rechecked.

- i. If blade angle range, for left and right pedal settings, cannot be obtained using above procedure, this indicates pedal travel is either too great or too small. Use following procedure to check and adjust pedal travel:
  - 1) Add right and left pedal angles together. If total is less than 34.0° pedal total travel is too small. If total is greater than 35.5° total travel is too great.
  - 2) If total travel is too small, first increase right pedal travel by increasing length of C121-9 push-pull tube. To increase left pedal travel, decrease length of C343-3 push-pull tube.

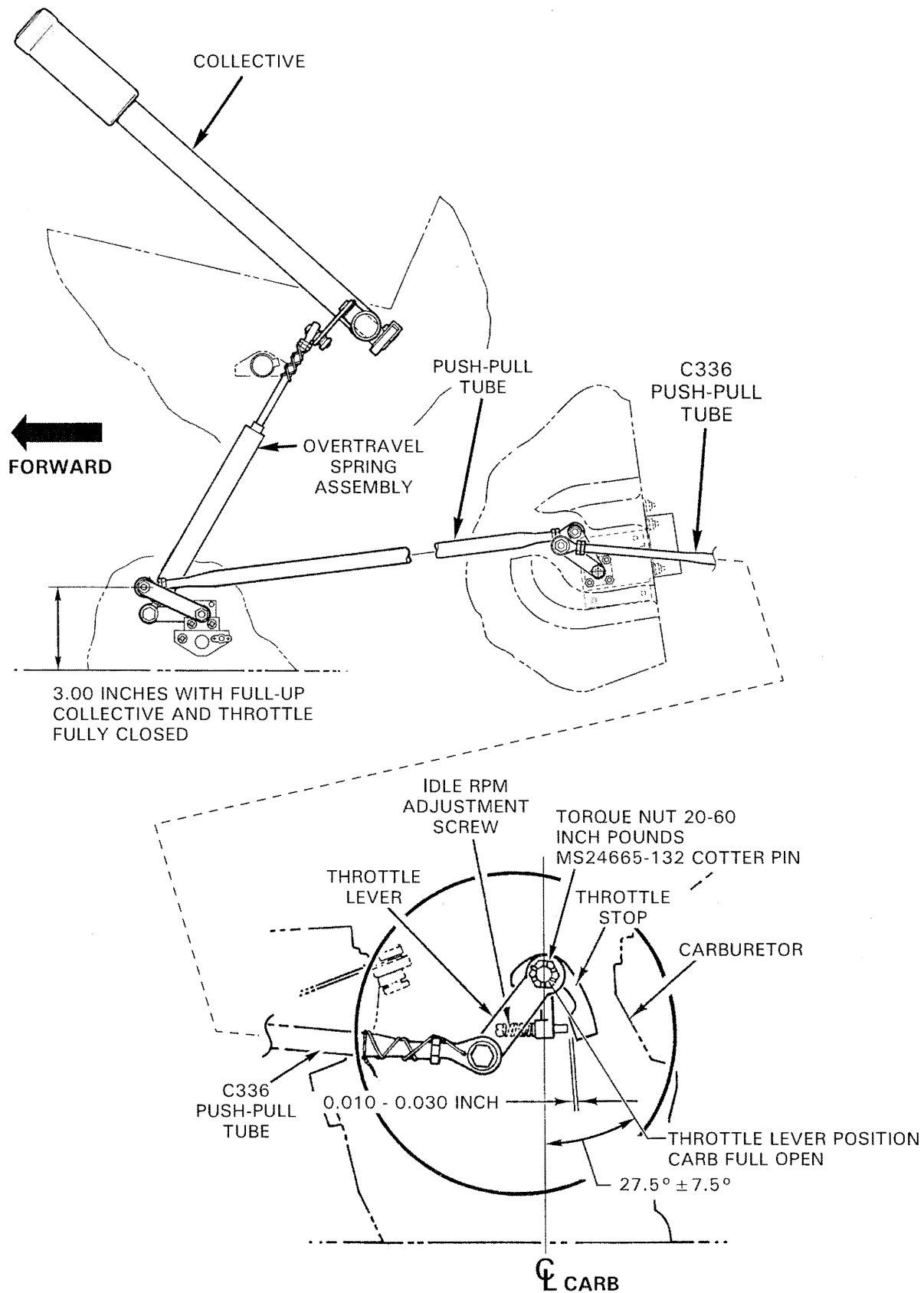

**FIGURE 10-8 THROTTLE CORRELATION RIGGING (CARBURETED SHIPS)**

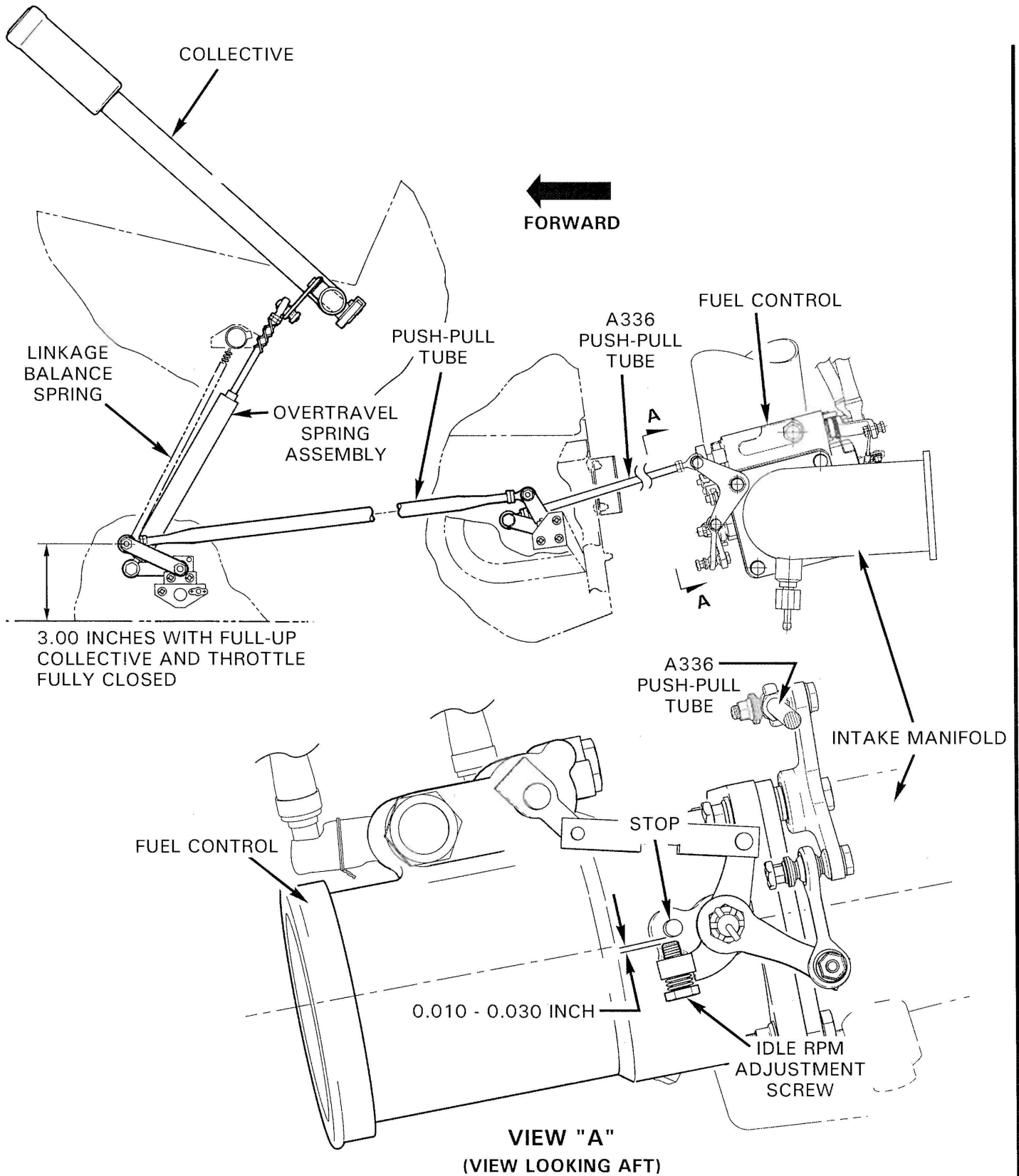

**FIGURE 10-8A THROTTLE CORRELATION RIGGING (FUEL INJECTED SHIPS)**

Intentionally blank

### 10.140 Tail Rotor Rigging (cont'd)

- 3) To decrease the total travel, shorten the C121-9 push-pull tube for right pedal travel and increase the length of C343-3 or C343-9 push-pull tube for left pedal travel.
- 4) Recheck the tail rotor blade angles per steps e) through h) above.
- j) Ensure all rod ends are installed properly by checking the push-pull tube witness holes. Tighten all rod end palnuts and jam nuts. Torque stripe all nuts.
- k) Balance tail rotor per Section 10.240.

### 10.150 Throttle Correlation Rigging (see Figure 10-8)

For in-service check and adjustment:

1. Verify idle rpm is correct with engine warm, clutch fully engaged, and throttle closed. Adjust O-540 idle to 53-57% and IO-540 idle to 58-62%.
2. Shut down helicopter.
3. Rotate twist-grip throttle fully closed through overtravel spring pressure to positive stop. Holding throttle tight against stop, raise collective full up while observing throttle arm on carburetor or fuel control, as applicable. Throttle arm should move 0.010-0.030 inch off of idle stop screw when collective up-stop is reached.
4. If necessary, adjust length of throttle push-pull tube at carburetor or fuel control, as applicable.
5. Standard torque jam nut(s) per Section 1.320, check witness holes, and torque stripe per Figure 2-1.

### 10.160 Actuator Rigging

No field adjustment of actuator-engaged belt tension is permitted. Adjust actuator's down-limit stop screw so there is a delay of less than 5 seconds before rotor starts turning when actuator is engaged at start up.

### 10.200 TRACK AND BALANCE

The Chadwick-Helmuth Vibrex system, the TEC ACES system, the Dynamic Solutions Systems' MicroVib system, or equivalent equipment is required to perform dynamic rotor balancing and in-flight tracking checks.

10.210 Equipment Requirements

The following list of equipment may be used on the R44 for track and balance:

- a) Balancers
  - Chadwick-Helmuth 177M05
  - Model Number 177M-6
  - 177M-6A
  - 177M-7
  - 177M-7A
  - 8350 series
  - M192 series
  - or equivalent equipment

- b) Strobex
  - Chadwick-Helmuth 135M-10\*
  - Model Number 135M-10A\*, B\* and C\*
  - 135M-11
  - or equivalent equipment

\* When tracking the main rotor using the 135M-10 series Strobex a double interrupter must be used.

- c) Cables, accelerometers/velocimeters, pickups, and targets\*\*
 

Chadwick-Helmuth	3140	D.C. Adapter Cable
Model Number	3030	Magnetic pickup
	3319-1 or 10808-25	Magnetic pickup cable
	4177	Accelerometer
	4296-1 and -2	Accelerometer Cable
	3300	Target Patches
	4270	Target Patches
	7310	Velocimeter
	11210-20/-50	Velocimeter Cable

- d) Brackets\*\*
  - Robinson MT121-1 Magnetic Pickup Bracket

- e) Charts\*\*
  - Robinson Main Rotor Chart
  - Tail Rotor Chart

\*\* As required by the balancing equipment being used.

10.220 Equipment Installation

10.221 Main Rotor Equipment Installation (see Figure 10-9A)

Refer to specific manufacturer's installation instructions when using balancing equipment other than Chadwick-Helmuth. Install Chadwick-Helmuth equipment as follows:

- a) Install the accelerometer/velocimeter under the upper console left-side attachment screw with cable connector pointing outboard.

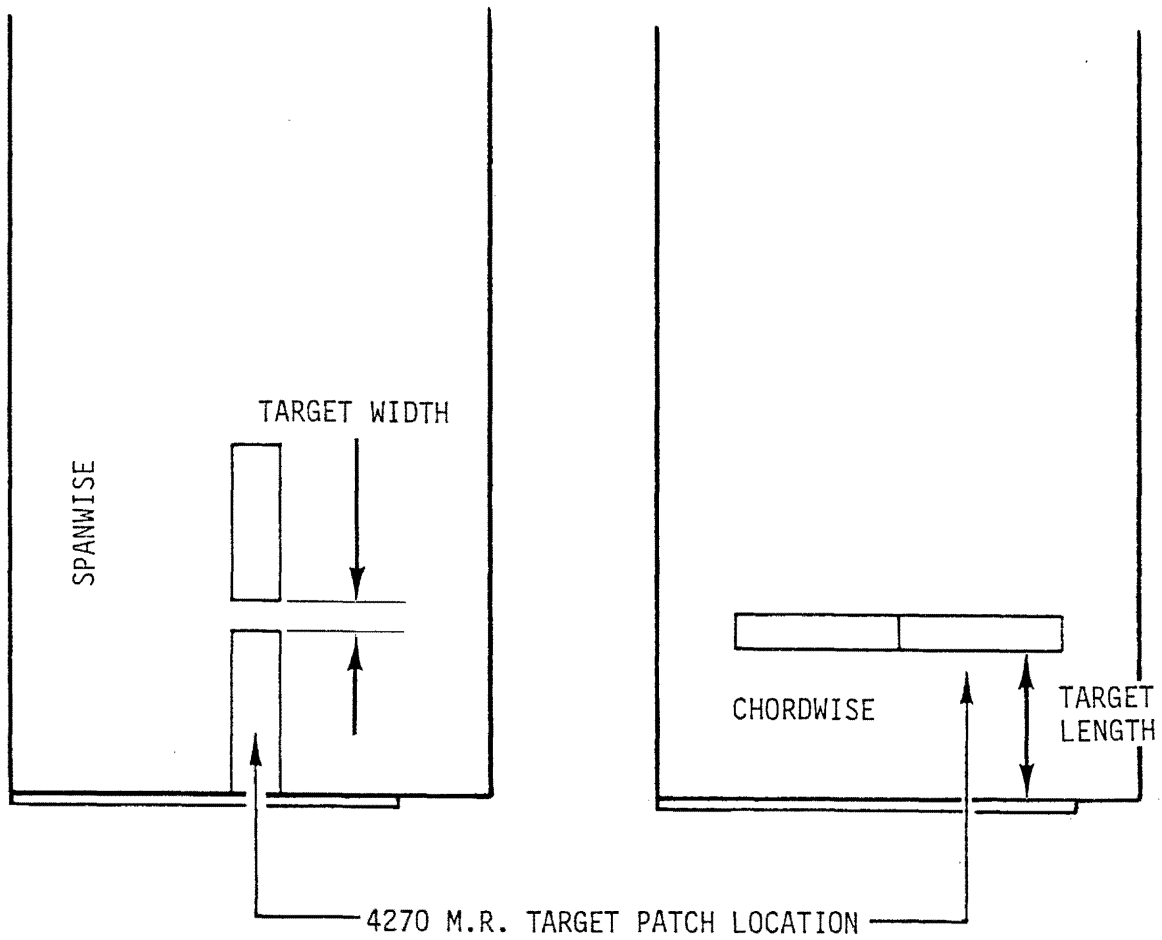

FIGURE 10-9 MAIN ROTOR TARGET PATCH LOCATION

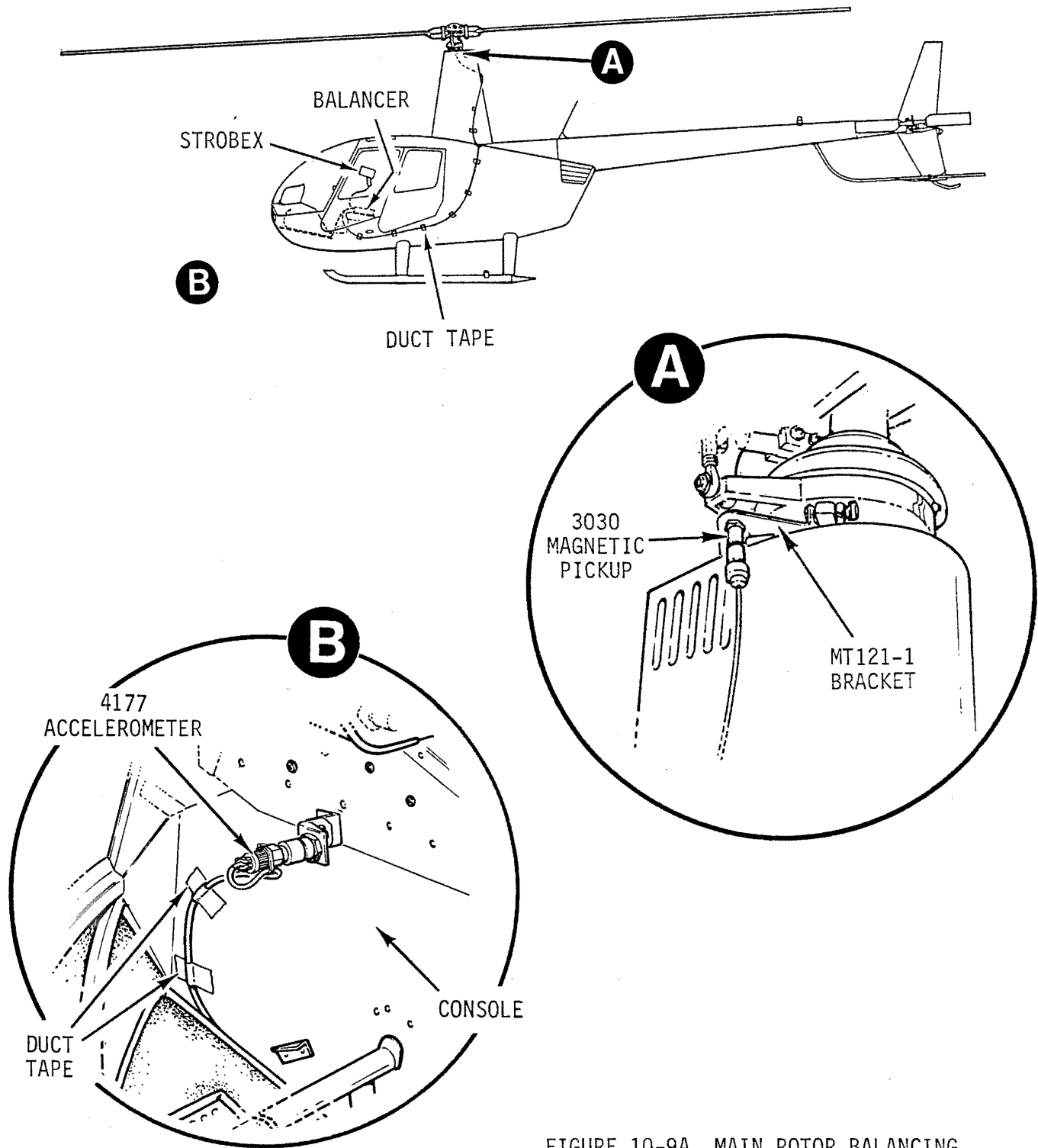

FIGURE 10-9A MAIN ROTOR BALANCING EQUIPMENT INSTALLATION

**10.221 Main Rotor Equipment Installation (cont'd)**

- b) Install MT121-1 Bracket onto the lower right-hand side of the swashplate. |

**WARNING**

Ensure attachment bolts are torqued to 200 in.-lb plus nut drag. The MT121-1 Bracket will remain installed for in-flight track and balance. |

- c) Install the 3030 magnetic pickup onto the MT121-1 Bracket. Set the interrupter pickup gap to 0.030" ± 0.010". |
- d) Attach the cable to the magnetic pickup. Pull collective stick full up and cyclic stick full left. Secure the cable to the mast fairing with duct tape. Route the cable to the lower front of the left door frame. Secure the cable every 12 inches with duct tape. |

**CAUTION**

Security of the cable is essential as the helicopter will be flown at Vne.

- e) Attach the cable to the accelerometer/velocimeter mounted on the left forward hold down screw of the console. Secure with duct tape.

**CAUTION**

Ensure the cable cannot become entangled with tail rotor pedals.

- f) Attach the cables to the balancer and secure excess cable to the bracket in front of the left seat.
- g) Apply the 4270 target tapes to the main rotor blades per Figure 10-9.

## 10.222 Tail Rotor Equipment Installation (see Figures 10-9C and 10-9D)

**NOTE**

Prior to installing balancing equipment, verify blades are clean and smooth, no debris under tip covers (square tip blades), rod end and spherical bearing play are within limits, and elastomeric bearings (if applicable) are satisfactory.

1. Install accelerometer/velocimeter bracket under upper forward tail rotor gearbox output seal housing attachment bolt. Connector end of accelerometer/velocimeter must point up.
2. If using a Vibrex 2000-series balancer with photocell, install photocell bracket between velocimeter and velocimeter bracket as shown in Figure 10-9C.
3. If using Strobex to obtain clock angle, install a target tape spanwise facing outboard on one arm of tail rotor hub. If using photocell to obtain clock angle, install a target tape spanwise facing inboard on one arm of tail rotor hub.
4. Connect cable(s) to accelerometer/velocimeter and photocell (if used). Route cable(s) forward and wrap around tailcone several times. Secure with duct tape.

**WARNING**

Ensure cable(s) cannot entangle tail rotor.

5. If using Strobex to obtain clock angle, route cable to a position located approximately 20 feet to left of tail rotor. Place sandbags (or similar) on cable to prevent cable movement. If using photocell to obtain clock angle, cables may be routed into cabin and secured with duct tape to prevent cable movement.
6. Connect cable(s) to balancer.

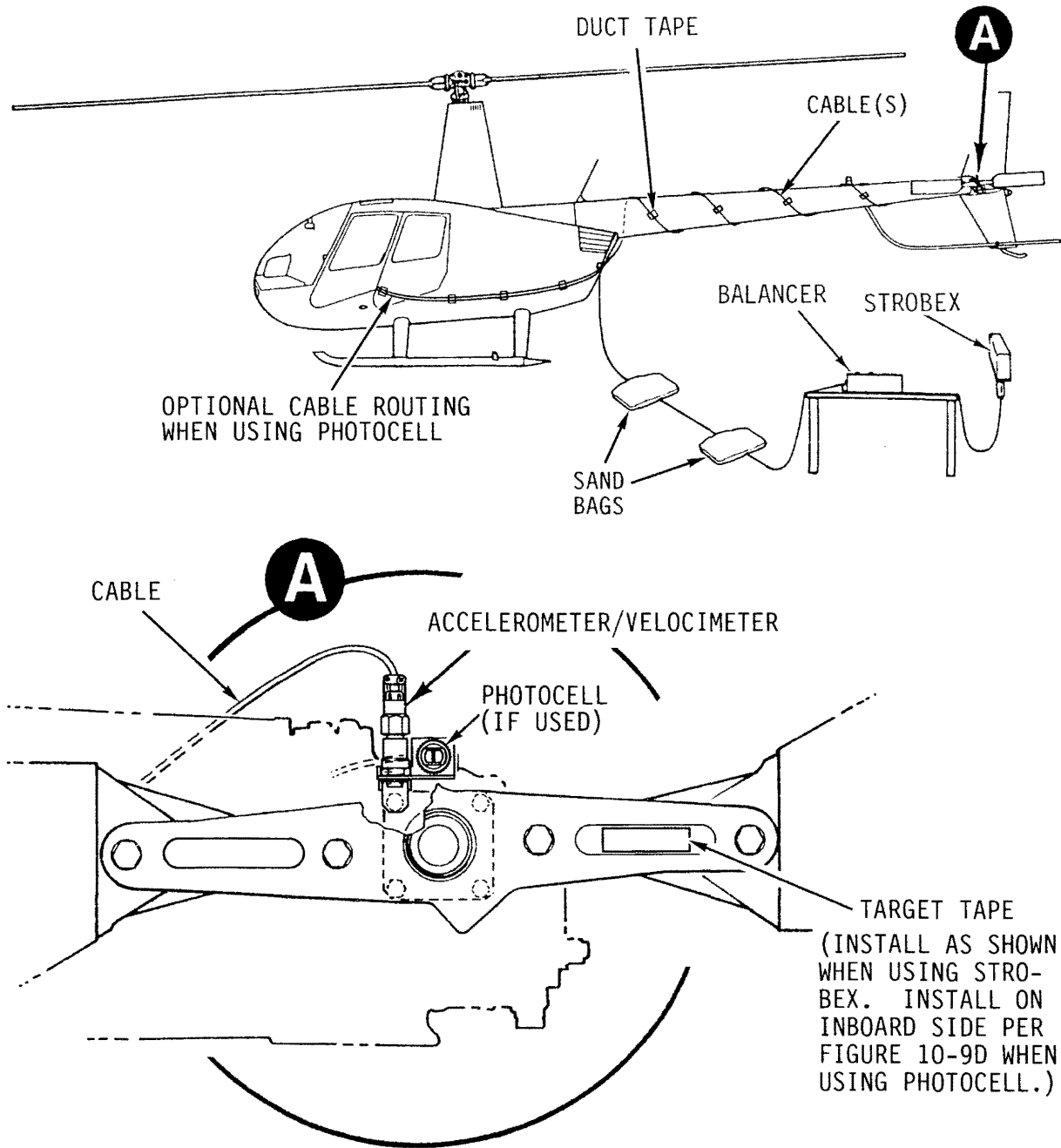

**FIGURE 10-9C**  
**TAIL ROTOR BALANCING EQUIPMENT INSTALLATION**

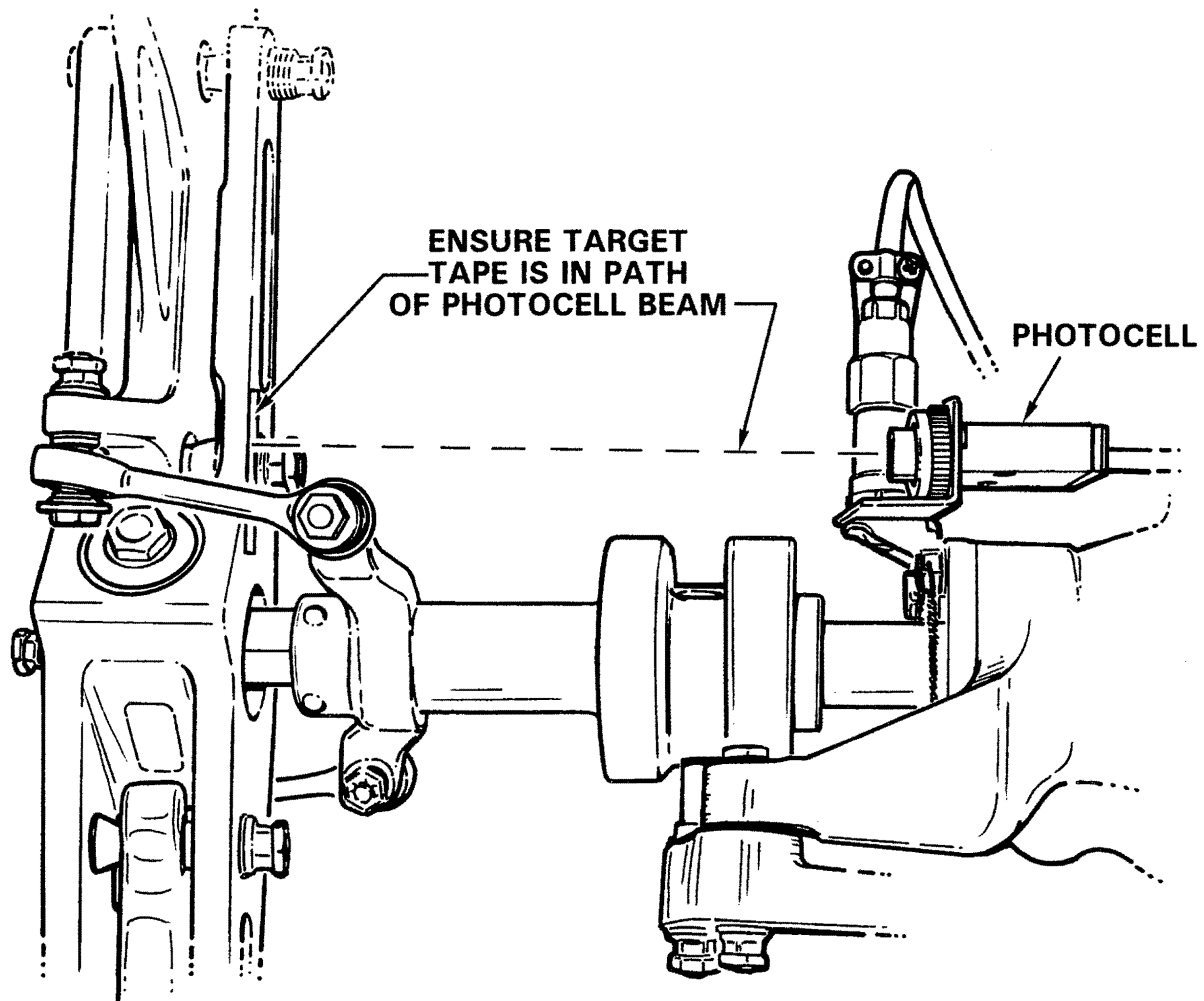

**(VIEW LOOKING FORWARD)**

**FIGURE 10-9D**

**TAIL ROTOR PHOTOCELL INSTALLATION**

Intentionally Blank

DATE \_\_\_\_\_ SERIAL NO. \_\_\_\_\_

PAGE \_\_\_\_\_

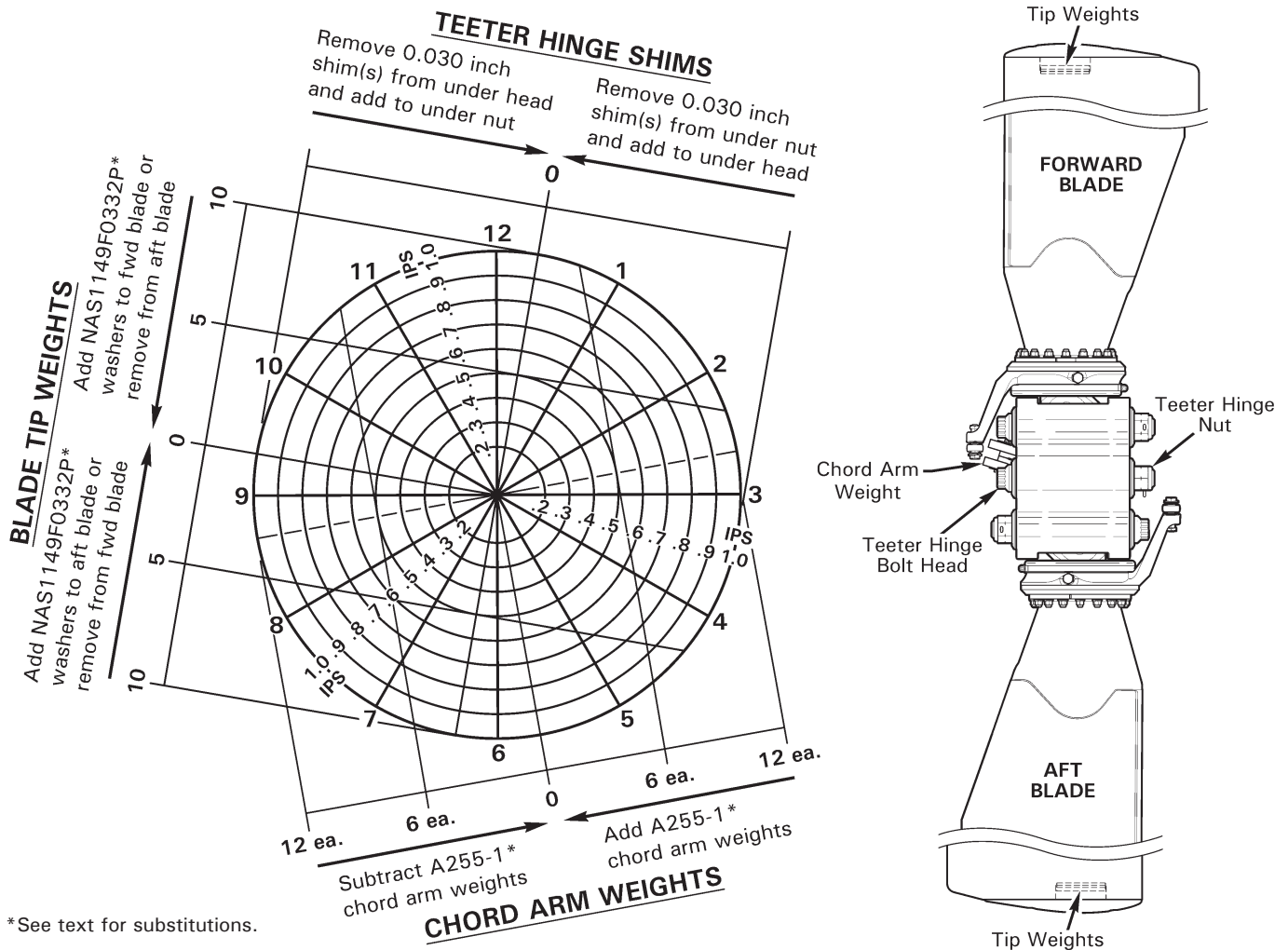

\*See text for substitutions.

BALANCE		TRACK (KNOTS)										
CLOCK	IPS	HOVER	CLIMB	50	60	70	80	90	100	110	120	130

Adjustment: \_\_\_\_\_

CLOCK	IPS	HOVER	CLIMB	50	60	70	80	90	100	110	120	130

Adjustment: \_\_\_\_\_

CLOCK	IPS	HOVER	CLIMB	50	60	70	80	90	100	110	120	130

Adjustment: \_\_\_\_\_

CLOCK	IPS	HOVER	CLIMB	50	60	70	80	90	100	110	120	130

**FIGURE 10-10 MAIN ROTOR TRACK AND BALANCE CHART**

10.230 Main Rotor Track and Balance Procedure

## NOTE

Prior to installing balancing equipment, verify blades are clean and smooth, rod ends & spherical bearings & scissors play are within limits, correct upper (rotating) scissors friction, correct swashplate tilting friction, and coning hinge frictions. Verify interrupter is opposite chord arm.

In-flight track and balance is accomplished using the following testing and adjustment sequence:

1. Check main rotor track in a hover and record data. Adjust track by shortening high blade pitch link per § 10.232 to bring track within 0.25 inch.
2. Check main rotor balance in a hover and record data. Adjust balance as indicated by main rotor balance chart to within 0.2 IPS (inches per second).
3. Fly helicopter at 50, 60, 70, 80, 90, 100, 110, 120, and 130 knots. Check track at each airspeed and record.

## WARNING

**Do not exceed  $V_{NE}$  of helicopter when checking in-flight track.**

4. Make slight tab adjustment to correct for a climbing blade by bending trim tab down per § 10.233.
5. Repeat steps 3 & 4 as required until track is within 3/8 inch at all airspeeds.
6. Readjust main rotor balance in a hover to no greater than 0.2 IPS.
7. Check autorotational RPM per § 10.250. Adjust as required.
8. Check main rotor balance in a hover. Verify no greater than 0.2 IPS. Adjust as required.

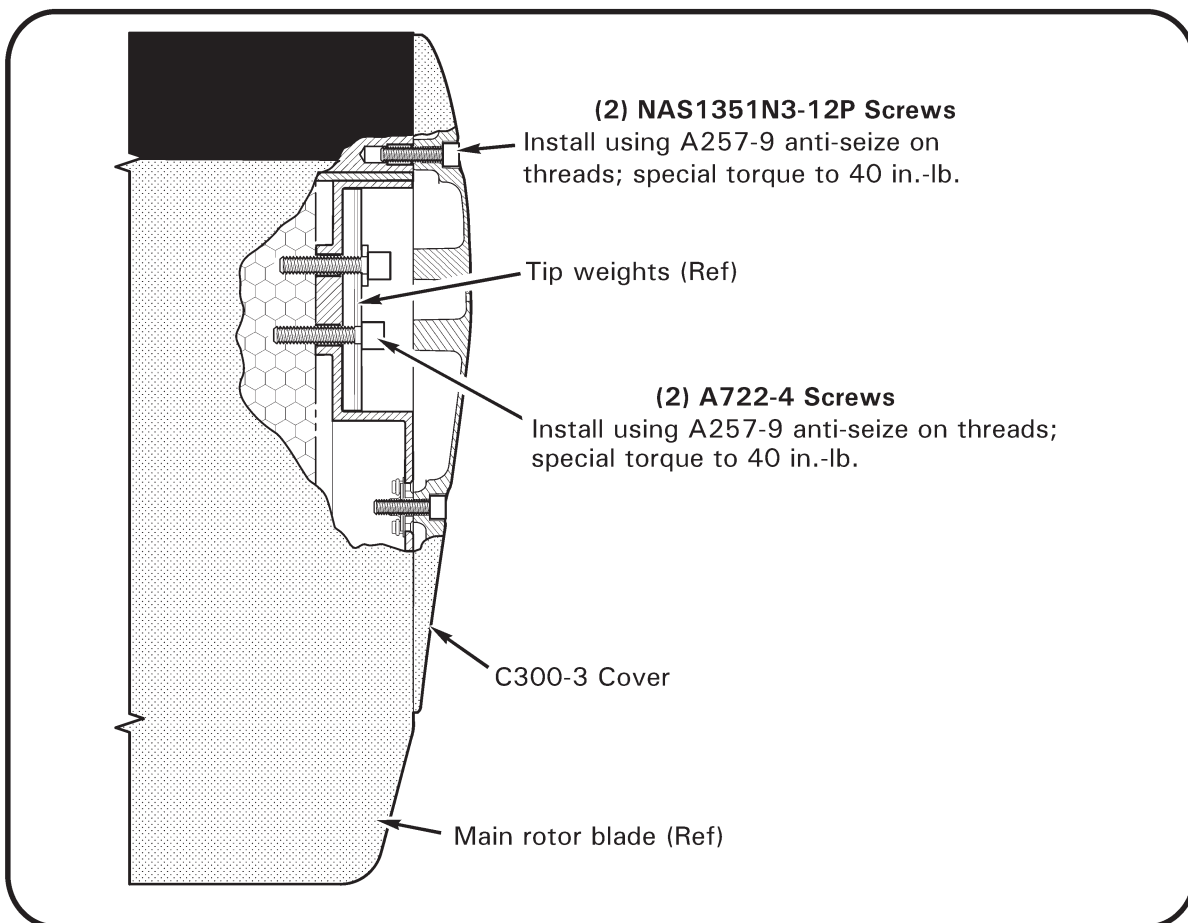

FIGURE 10-11 MAIN ROTOR BLADE TIP

10.231 Main Rotor Balance Adjustment

**WARNING**

**A rotor which is smooth after balancing but goes out of balance within a few flights is suspect and must be examined by RHC before further flight.**

**A. Tip Weights (Spanwise Balance Adjustment)**

1. Remove screws securing tip cover to blade. Balance rotor assembly spanwise by adjusting tip weights as required per Figure 10-10. Washers may be trimmed. Refer to Figure 10-11. Apply light coat A257-9 anti-seize to threads and install screws securing tip weights to blade; special torque screws to 40 in.-lb. Apply light coat A257-9 anti-seize to threads and install screws securing tip cover to blade; special torque screws to 40 in.-lb.

- |                                      |   |  |
|--------------------------------------|---|--|
| (1) AN960-10 or NAS1149F0363P Washer | = | (2) AN960-10L or NAS1149F0332P Washers |
| (1) C298-2 Weight                    | = | (5) AN960-10 or NAS1149F0363P Washers  |
| (1) C298-3 Weight                    | = | (11) AN960-10 or NAS1149F0363P Washers |
| (1) C298-4 Weight                    | = | (4) C298-3 Weights                     |

**B. Teeter Hinge Bolt Shims (Chordwise Balance Adjustment - Coarse Adjustment)**

1. Remove and discard teeter hinge nut cotter pin. Remove nut, thrust washer, and any shims.
2. Have two people cone the main rotor blades. Push out teeter hinge bolt (and any shims) with another bolt.
3. Balance rotor assembly chordwise by moving (or exchanging) existing teeter hinge shims to other side of bolt (under head or under nut) as required per Figure 10-10. Install teeter hinge bolt per § 28-10.

**C. Chord Arm Weight (Chordwise Balance Adjustment - Fine Adjustment)**

1. Balance rotor assembly chordwise by adjusting chord arm weights or washers per Figure 10-10. Total weight not to exceed four A255-2 weights (or equivalent).

- |                   |   |                     |
|-------------------|---|---------------------|
| (1) A255-1 Weight | = | (8) AN970-4 Washers |
| (1) A255-2 Weight | = | (3) A255-1 Weights  |

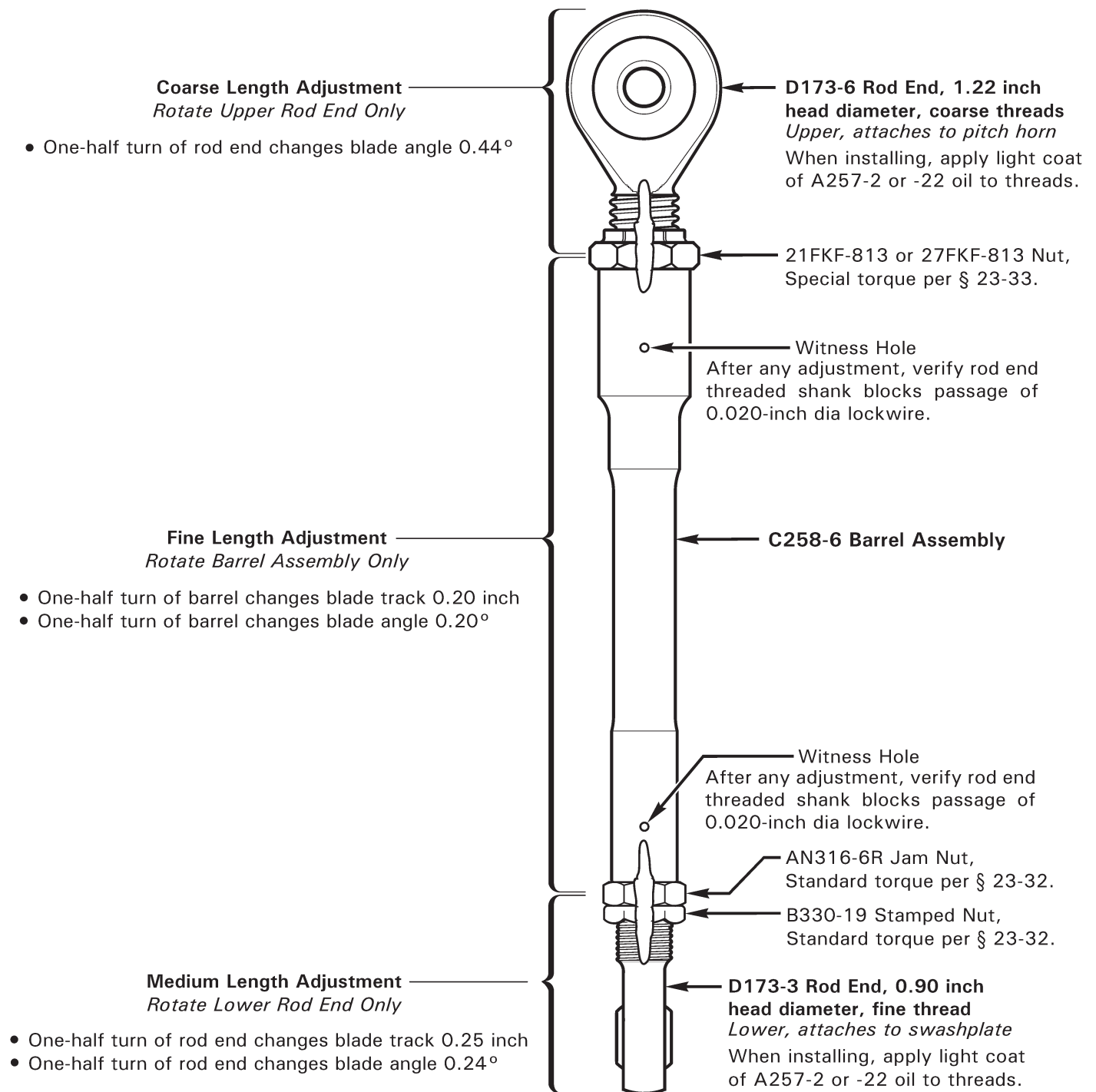

**FIGURE 10-12A C258-8 MAIN ROTOR PITCH LINK**

### 10.232 Main Rotor Pitch Link Adjustment

**NOTE**

Shorten high pitch blade when adjusting track in a hover.

**NOTE**

During rigging, adjust both pitch links exactly the same for collective adjustments.

**NOTE**

Adjustment procedures vary by pitch link part number. Perform adjustment procedure per Part A, B, or C that corresponds to installed pitch links.

#### A. C258-8 Pitch Link Adjustment

**CAUTION**

C258-8 pitch link assembly must be installed in pairs.

Fine Length Adjustment: Adjust barrel assembly only, per the following steps:

1. Refer to Figure 10-12A. Using backup wrench on barrel assembly, loosen stamped nut and jam nut at lower rod end, and 21FKF-813 or 27FKF-813 nut at upper rod end.
2. Rotate barrel assembly to shorten or lengthen pitch link as required. One-half turn of barrel changes blade track approximately 0.20 inch. One-half turn of barrel changes blade angle approximately 0.20°. For finer adjustment, rotate less than one-half turn as required.
3. Refer to Figures 2-1 & 2-1A. Position rod ends to allow as much pitch link rotation as possible without binding. Using backup wrench on barrel assembly, special torque 21FKF-813 or 27FKF-813 nut per § 23-33, and standard torque jam nut and stamped nut at lower rod end per § 23-32. Verify rod ends' threaded shanks block passage of 0.020-inch diameter lockwire through barrel assembly witness holes. Torque stripe link per Figure 10-12A.
4. Repeat steps on opposite pitch link as required.

10.232 Main Rotor Pitch Link Adjustment (continued)**A. C258-8 Pitch Link Adjustment (continued)**

Medium Length Adjustment: Adjust lower rod end only, per the following steps:

1. Refer to Figure 10-12A. Using backup wrench on barrel assembly, loosen stamped nut and jam nut at lower rod end. Remove hardware securing lower rod end to swashplate.
2. Rotate lower rod end to shorten or lengthen pitch link as required. One-half turn of lower rod end changes blade track approximately 0.25 inch. One-half turn of lower rod end changes blade angle by approximately  $0.24^\circ$ .
3. Install hardware securing rod end to swashplate and standard torque fasteners per § 23-32. Torque stripe per Figure 2-1.
4. Refer to Figures 2-1 & 2-1A. Position lower rod end to allow as much pitch link rotation as possible without binding. Using backup wrench on barrel assembly, standard torque jam nut and stamped nut at lower rod end per § 23-32. Verify lower rod end threaded shank blocks passage of 0.020-inch diameter lockwire through barrel assembly lower witness hole. Torque stripe link per Figure 10-12A.
5. Repeat steps on opposite pitch link as required.

Coarse Length Adjustment: Adjust upper rod end only, per the following steps:

1. Refer to Figure 10-12A. Using backup wrench on barrel assembly, loosen 21FKF-813 or 27FKF-813 nut at upper rod end. Remove hardware securing upper rod end to pitch horn.
2. Rotate upper rod end to shorten or lengthen pitch link as required. One-half turn of upper rod end changes blade angle by approximately  $0.44^\circ$ .
3. Install hardware securing rod end to pitch horn and standard torque fasteners per § 23-32. Torque stripe per Figure 2-1.
4. Refer to Figures 2-1 & 2-1A. Position upper rod end to allow as much pitch link rotation as possible without binding. Using backup wrench on barrel assembly, special torque 21FKF-813 or 27FKF-813 nut per § 23-33. Verify upper rod end threaded shank blocks passage of 0.020-inch diameter lockwire through barrel assembly upper witness hole. Torque stripe link per Figure 10-12A.
5. Repeat steps on opposite pitch link as required.

Intentionally Blank

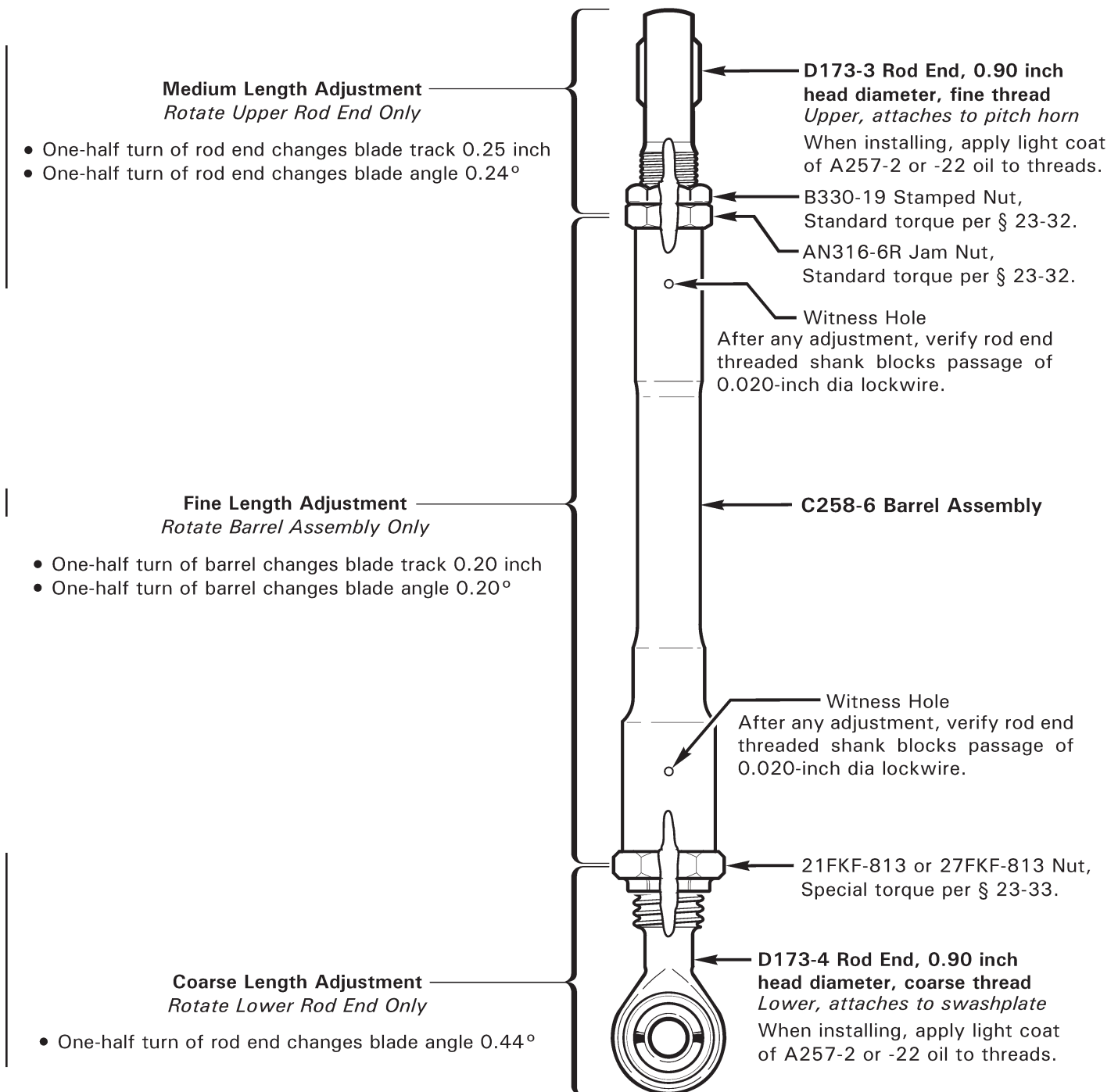

**FIGURE 10-12B C258-5 MAIN ROTOR PITCH LINK**

10.232 Main Rotor Pitch Link Adjustment (continued)**B. C258-5 Pitch Link Adjustment**

Fine Length Adjustment: Adjust barrel assembly only, per the following steps:

1. Refer to Figure 10-12B. Using backup wrench on barrel assembly, loosen 21FKF-813 or 27FKF-813 nut at lower rod end, and stamped nut and jam nut at upper rod end.
2. Rotate barrel assembly to shorten or lengthen pitch link as required. One-half turn of barrel changes blade track approximately 0.20 inch. One-half turn of barrel changes blade angle approximately  $0.20^\circ$ . For finer adjustment, rotate less than one-half turn as required.
3. Refer to Figures 2-1 & 2-1A. Position rod ends to allow as much pitch link rotation as possible without binding. Using backup wrench on barrel assembly, special torque 21FKF-813 or 27FKF-813 nut per § 23-33, and standard torque jam nut and stamped nut at upper rod end per § 23-32. Verify rod ends' threaded shanks block passage of 0.020-inch diameter lockwire through barrel assembly witness holes. Torque stripe link per Figure 10-12B.
4. Repeat steps on opposite pitch link as required.

Medium Length Adjustment: Adjust upper rod end only, per the following steps:

1. Refer to Figure 10-12B. Using backup wrench on barrel assembly, loosen stamped nut and jam nut at upper rod end. Remove hardware securing rod end to pitch horn.
2. Rotate upper rod end to shorten or lengthen pitch link as required. One-half turn of upper rod end changes blade track approximately 0.25 inch. One-half turn of upper rod end changes blade angle by approximately  $0.24^\circ$ .
3. Install hardware securing rod end to pitch horn and standard torque fasteners per § 23-32. Torque stripe per Figure 2-1.
4. Refer to Figures 2-1 & 2-1A. Position upper rod end to allow as much pitch link rotation as possible without binding. Using backup wrench on barrel assembly, standard torque jam nut and stamped nut at upper rod end per § 23-32. Verify upper rod end threaded shank blocks passage of 0.020-inch diameter lockwire through barrel assembly upper witness hole. Torque stripe link per Figure 10-12B.
5. Repeat steps on opposite pitch link as required.

10.232 Main Rotor Pitch Link Adjustment (continued)**B. C258-5 Pitch Link Adjustment (continued)**

Coarse Length Adjustment: Adjust lower rod end only, per the following steps:

1. Refer to Figure 10-12B. Using backup wrench on barrel assembly, loosen 21FKF-813 or 27FKF-813 nut at lower rod end. Remove hardware securing lower rod end to swashplate.
2. Rotate lower rod end to shorten or lengthen pitch link as required. One-half turn of lower rod end changes blade angle by approximately  $0.44^{\circ}$ .
3. Install hardware securing rod end to swashplate and standard torque fasteners per § 23-32. Torque stripe per Figure 2-1.
4. Refer to Figures 2-1 & 2-1A. Position lower rod end to allow as much pitch link rotation as possible without binding. Using backup wrench on barrel assembly, special torque 21FKF-813 or 27FKF-813 nut per § 23-33. Verify lower rod end threaded shank blocks passage of 0.020-inch diameter lockwire through barrel assembly lower witness hole. Torque stripe link per Figure 10-12B.
5. Repeat steps on opposite pitch link as required.

Intentionally Blank

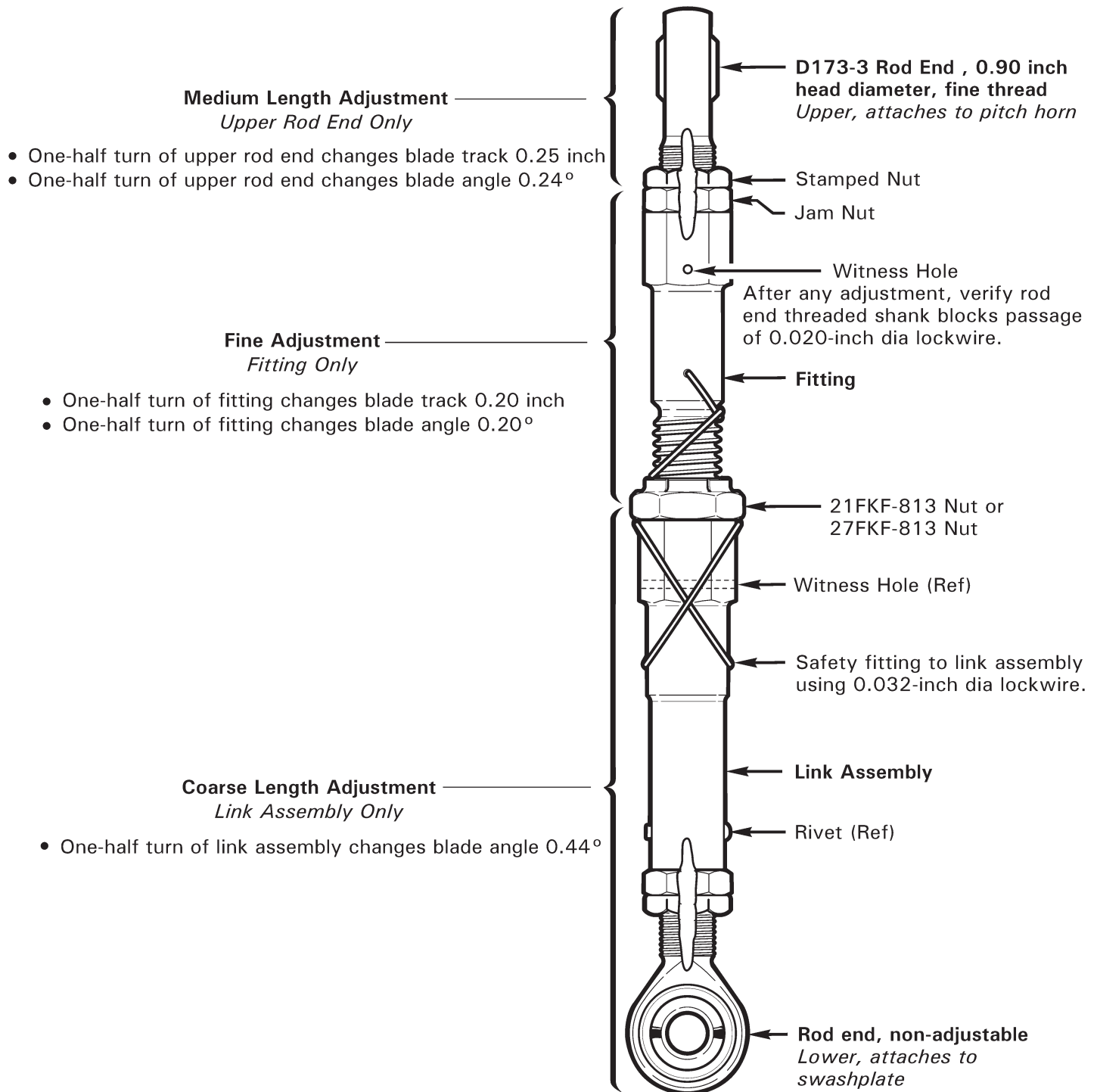

**FIGURE 10-12C C258-1 MAIN ROTOR PITCH LINK**

10.232 Main Rotor Pitch Link Adjustment (continued)**C. C258-1 Pitch Link Adjustment**

Fine Length Adjustment: Adjust fitting only, per the following steps:

1. Refer to Figure 10-12C. Cut and discard pitch link assembly safety wire. Using backup wrench on link assembly, loosen 21FKF-813 or 27FKF-813 nut; using backup wrench on fitting, loosen stamped nut and jam nut at upper rod end.
2. Rotate fitting to shorten or lengthen pitch link as required. One-half turn of fitting changes blade track approximately 0.20 inch. One-half turn of fitting changes blade angle approximately 0.20°. For finer adjustment, rotate less than one-half turn as required.
3. Refer to Figure 2-1A. Position rod ends to allow as much pitch link rotation as possible without binding.
4. Using backup wrench on link assembly, special torque 21FKF-813 or 27FKF-813 nut per § 23-33. Using backup wrench on fitting, standard torque jam nut and stamped nut at upper rod end per § 23-32. Verify upper rod end and fitting threaded shanks block passage of 0.020-inch diameter lockwire thru witness holes. Safety fitting to link assembly using 0.032-inch diameter lockwire. Torque stripe link per Figure 10-12C.
5. Repeat steps on opposite pitch link as required.

Medium Length Adjustment: Adjust upper rod end only, per the following steps:

1. Refer to Figure 10-12C. Using backup wrench on fitting, loosen stamped nut and jam nut at upper rod end. Remove hardware securing rod end to pitch horn.
2. Rotate upper rod end to shorten or lengthen pitch link as required. One-half turn of upper rod end changes blade track approximately 0.25 inch. One-half turn of upper rod end changes blade angle by approximately 0.24°.
3. Install hardware securing rod end to pitch horn and standard torque fasteners per § 23-32. Torque stripe per Figure 2-1.
4. Refer to Figure 2-1A. Position upper rod end to allow as much pitch link rotation as possible without binding. Using backup wrench on fitting, standard torque jam nut and stamped nut at upper rod end per § 23-32. Verify upper rod end's threaded shank blocks passage of 0.020-inch diameter lockwire through fitting witness hole. Torque stripe link per Figure 10-12C.
5. Repeat steps on opposite pitch link as required.

10.232 Main Rotor Pitch Link Adjustment (continued)**C. C258-1 Pitch Link Adjustment (continued)**

Coarse Length Adjustment: Adjust link assembly only, per the following steps:

1. Refer to Figure 10-12C. Cut and discard pitch link assembly safety wire. Using backup wrench on link assembly, loosen 21FKF-813 or 27FKF-813 nut. Remove hardware securing link assembly to swashplate.
2. Rotate link assembly to shorten or lengthen pitch link as required. One-half turn of link assembly changes blade angle by approximately  $0.44^{\circ}$ .
3. Install hardware securing link assembly's lower rod end to swashplate and standard torque fasteners per § 23-32. Torque stripe per Figure 2-1.
4. Position combined fitting & upper rod end to allow as much pitch link rotation as possible without binding. Using backup wrench on link assembly, special torque 21FKF-813 or 27FKF-813 nut per § 23-33. Verify fitting's threaded shank blocks passage of 0.020-inch diameter lockwire through link assembly witness hole. Safety fitting to link assembly using 0.032-inch diameter lockwire. Torque stripe link per Figure 10-12C.
5. Repeat steps on opposite pitch link as required.

Intentionally Blank

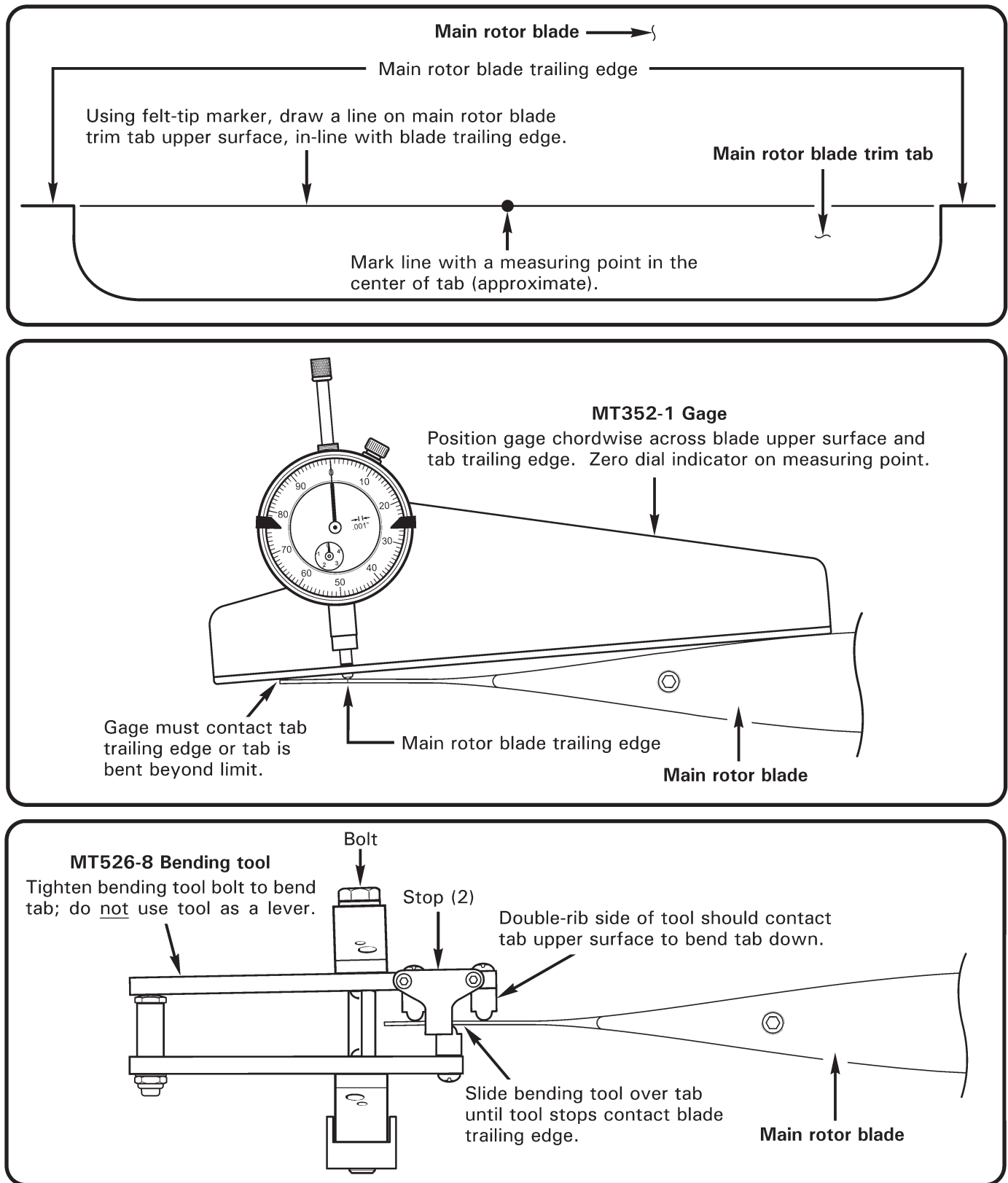

FIGURE 10-13 MAIN ROTOR BLADE TRIM TAB

10.233 Main Rotor Blade Trim Tab Adjustment**NOTE**

To correct for a "climbing" blade condition (blade spread that exceeds 3/8 inch with forward airspeed), bend high blade trim tab down.

**CAUTION**

Do not use other helicopter manufacturers' trim tab bending tools. Use of these tools will damage Robinson blades.

**CAUTION**

MT352-1 gage must contact trim tab trailing edge. If gage does not contact tab trailing edge, tab is bent beyond limit.

**CAUTION**

Tighten MT526-8 bending tool bolt to bend tab; do not use tool as a lever.

**CAUTION**

Bend tab upward only when absolutely necessary; bending tab upward can increase rotor vibration.

1. Using felt tip marker, ink mark main rotor blade trim tab per Figure 10-13. Mark line with a measuring point in the center of the tab (approximate).
2. Position MT352-1 gage chordwise across blade upper surface and tab trailing edge. Zero dial indicator on measuring point.
3. Position MT526-8 bending tool on tab per Figure 10-13. Slide tool completely over tab until tool stops contact blade trailing edge. Double-rib side of tool should contact tab upper surface to bend tab down. Double-rib side of tool should contact tab bottom surface to bend tab up.
4. Tighten MT526-8 bending tool bolt to bend tab. Make slight bends and re-measure tab with MT352-1 gage. Bend trim tab 0.015 inch (down) to effect dynamic movement of main rotor blade tip approximately 0.2 inch (downward).

10.234 Main Rotor Track and Balance Troubleshooting

SYMPTOM	PROBABLE CAUSE	CORRECTION
Excessive Cyclic or Stick Shake	Rough or binding A205-5 fork assembly (upper swashplate).	Replace or refer to § 8.600.
	Brinelled spindle bearing (rough movement).	Send blade(s) to RHC or Service Center for spindle bearing replacement.
	Rough blade surface (chipped paint).	Repair blades per § 28-50.
	Rough or binding pitch links.	Replace pitch link rod ends.
	MR blade boot misaligned.	Realign or replace boot per §§ 28-11.
	MR teeter or coning hinge binding.	Replace bearings per § 28-21.
	MR blade trim tabs bent upward.	Bend trim tabs evenly down per § 10.233.
	Blade mismatch.	Send blade(s) to RHC for replacement.
Excessive Ship Vibration	MR out of track and balance.	Track and balance per § 10.230.
	MR teeter or coning hinge friction.	Adjust hinge friction per § 28-32.
	MR teeter or coning hinge binding.	Replace bearings per § 28-21.
	Brinelled spindle bearing (rough movement).	Send blade(s) to RHC or Service Center for spindle bearing replacement.
	MR teeter hinge bearings worn.	Replace bearings per § 28-21.
Excessive Cyclic Stick Forces	Brinelled spindle bearing (rough movement).	Send blade(s) to RHC or Service Center for spindle bearing replacement.
Intermittent Blade Track Picture	MR teeter or coning hinge friction	Adjust hinge friction per § 28-32.
	MR coning hinge binding.	Replace bearings per § 28-21.
	MR teeter hinge not "broken-in."	Track and balance per § 10.230. Adjust track to minimize error.
	Brinelled spindle bearing (rough movement).	Send blade(s) to RHC or Service Center for spindle bearing replacement.
Radical Changes to Cyclic Trim	MR teeter hinge bearings worn.	Replace bearings per § 28-21.
	Brinelled spindle bearing (rough movement).	Send blade(s) to RHC for spindle bearing replacement.
Lateral Intermittent Ship Vibration	Engine misfiring due to malfunction in spark plugs, ignition leads, magneto, or engine not "broken-in."	Refer to Textron-Lycoming Maintenance Instructions.
4 per second Fore/Aft Oscillation	Aircraft CG out of limits.	Operate aircraft within CG envelope.
	Deteriorated / contaminated main gearbox rubber mount(s).	Replace main gearbox mounts.

Intentionally Blank

### 10.240 Tail Rotor Balance Procedure

Refer to specific manufacturer's installation instructions when using balancing equipment other than Chadwick-Helmuth Vibrex system.

Install Chadwick-Helmuth equipment per § 10.222. Set Function Knob on Balancer to appropriate channel. Set balancer RPM Range knob to X10 and set RPM to 231. With helicopter running with governor ON, view tail rotor assembly with Strobex. Tune Balancer while viewing target tape and adjusting RPM dial on Balancer. Record clock angle and IPS on tail rotor balance chart. Adjust as required until balance is less than 0.2 IPS.

Spanwise balance adjustments for C029-1 square-tip blades are made by adding, subtracting, or exchanging weights under the removable tip cover. Use C134-1 or -2 tip weights or AN960-8 or -8L washers. -8L washers may be trimmed as a very fine adjustment.

Spanwise balance adjustments for C029-2 and C029-3 round-tip blades are made by exchanging different diameter washers under nut securing blade's outboard retaining bolt. The bolt has sufficient length to allow necessary spanwise weight changes; verify 2–4 threads protruding past nut after torquing per § 23-32.

Chordwise balance is adjusted by adding, subtracting, or exchanging A141-14, A214-3, NAS1149F0463P/F0432P, or NAS1149D0463J/D0432J washers under nut securing blade's pitch link attaching bolt. Change pitch link attaching bolt length as required for proper thread engagement (see § 23-30, refer to IPC for allowable lengths).

DATE \_\_\_\_\_ SERIAL NO. \_\_\_\_\_  
 PAGE \_\_\_\_\_

**C008-9 TAIL ROTOR ASSEMBLY**

CHORDWISE WEIGHTS			
(1) NAS1149F0463P Washer	=	(2)	NAS1149F0432P Washers
(1) A214-3 Washer	=	(3.5)	NAS1149F0432P Washers
(1) A141-14 Washer	=	(5)	NAS1149F0432P Washers

SPANWISE WEIGHTS			
(1) C141-23 Washer	=	(3.5)	NAS1149F0663P Washers
(1) C141-24 Washer	=	(7)	NAS1149F0663P Washers
(2) NAS1149F0632P		(1)	NAS1149F0663P Washer

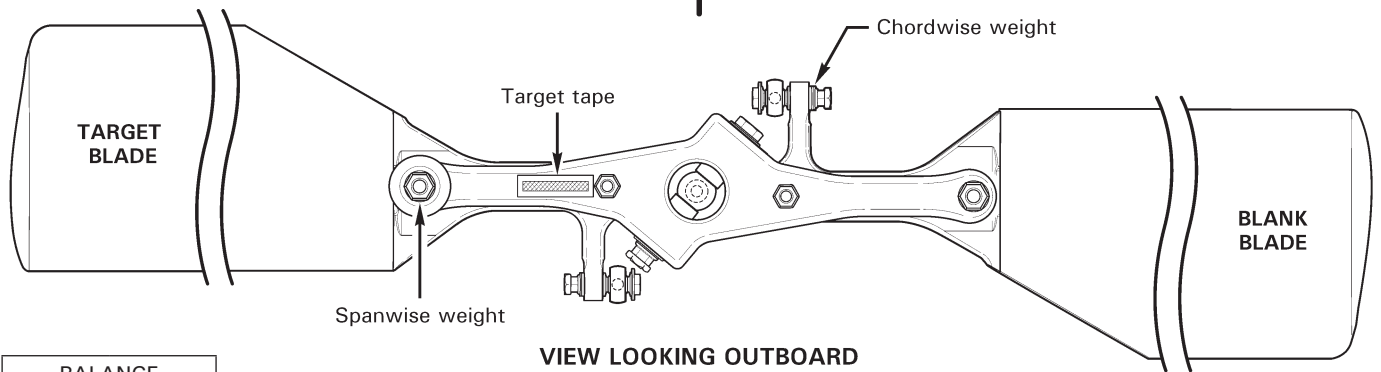
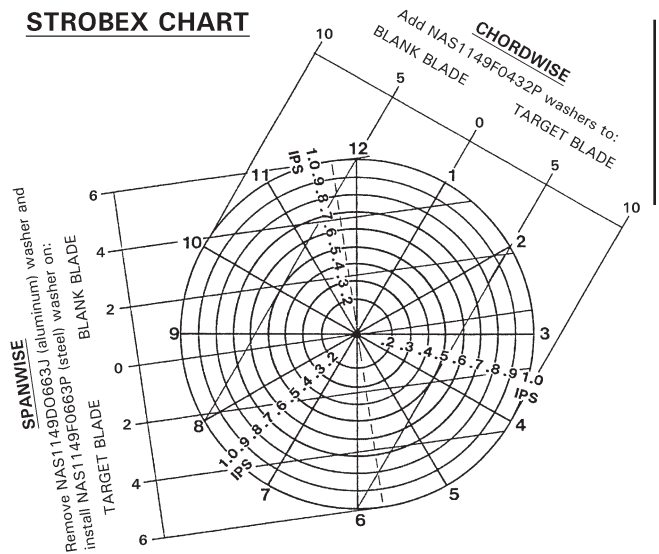
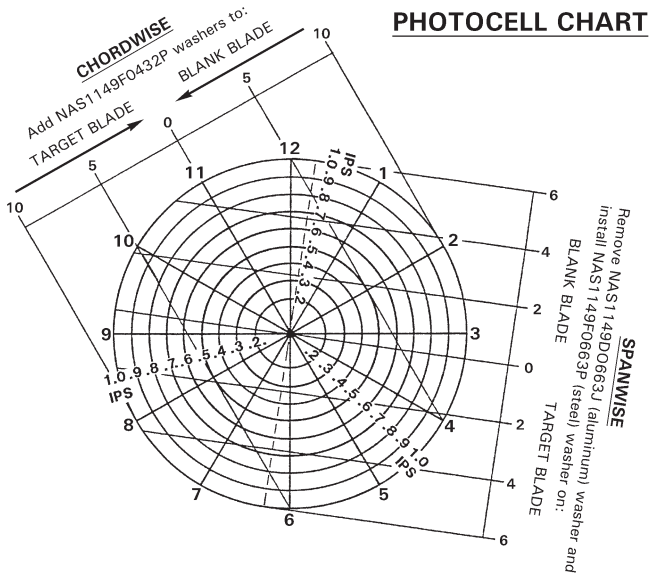

BALANCE	
CLOCK	IPS

ADJUSTMENT: \_\_\_\_\_

ADJUSTMENT: \_\_\_\_\_

ADJUSTMENT: \_\_\_\_\_

ADJUSTMENT: \_\_\_\_\_

**FIGURE 10-14 C008-9 TAIL ROTOR ASSEMBLY DYNAMIC BALANCE CHART**

DATE \_\_\_\_\_ SERIAL NO. \_\_\_\_\_  
 PAGE \_\_\_\_\_

**C008-4 TAIL ROTOR ASSEMBLY**

CHORDWISE WEIGHTS			
(1) NAS1149F0463P Washer	=	(2)	NAS1149F0432P Washers
(1) A214-3 Washer	=	(3.5)	NAS1149F0432P Washers
(1) A141-14 Washer	=	(5)	NAS1149F0432P Washers

SPANWISE WEIGHTS			
(1) C141-20 Washer	=	(5)	NAS1149F0563P Washers
(1) AN970-5 Washer	=	(13)	NAS1149F0563P Washers

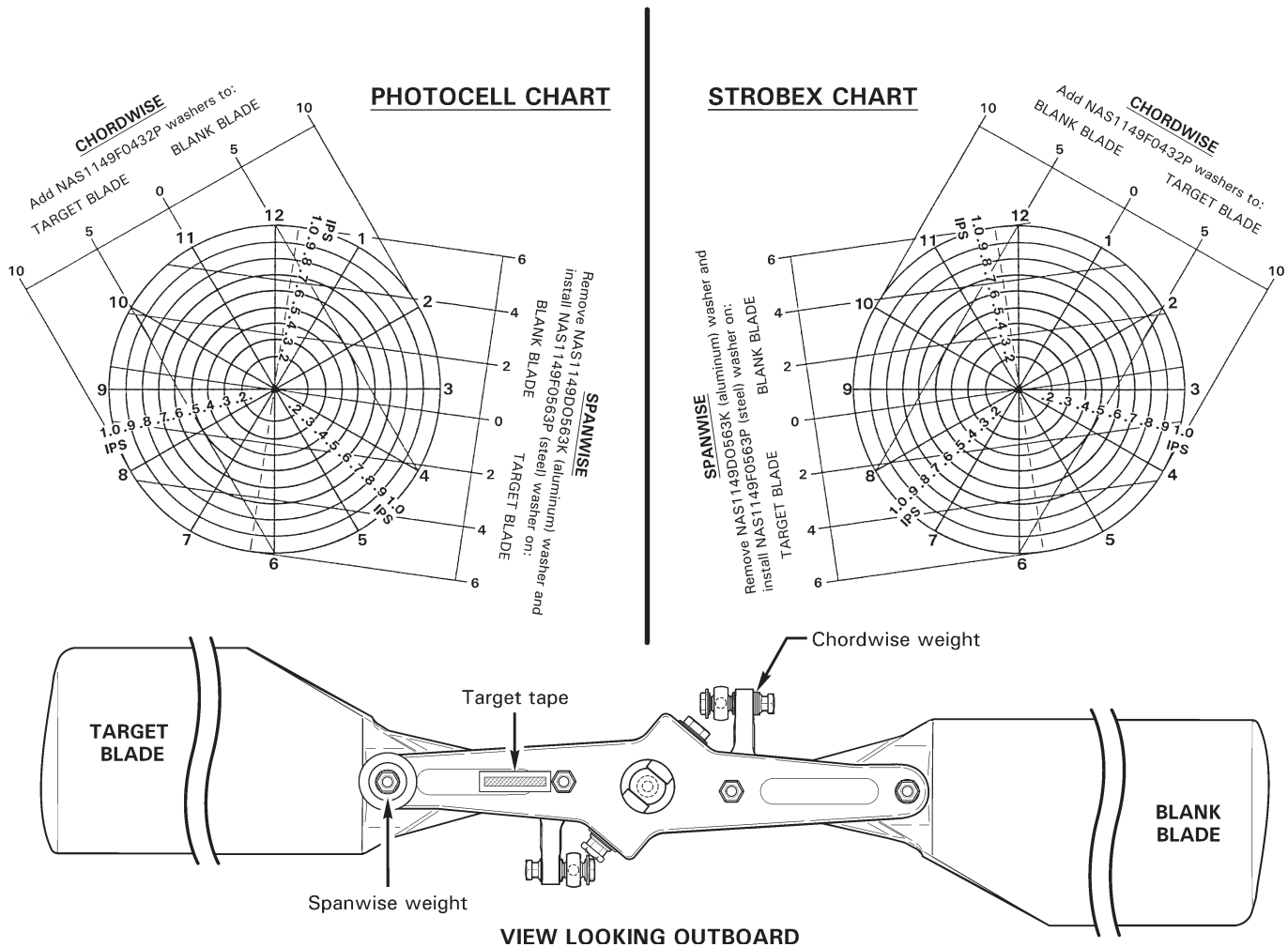

BALANCE	
CLOCK	IPS
CLOCK	IPS
CLOCK	IPS
CLOCK	IPS

ADJUSTMENT: \_\_\_\_\_

ADJUSTMENT: \_\_\_\_\_

ADJUSTMENT: \_\_\_\_\_

ADJUSTMENT: \_\_\_\_\_

**FIGURE 10-15 C008-4 TAIL ROTOR ASSEMBLY DYNAMIC BALANCE CHART**

DATE \_\_\_\_\_ SERIAL NO. \_\_\_\_\_  
 PAGE \_\_\_\_\_

**C008-2 TAIL ROTOR ASSEMBLY**

CHORDWISE WEIGHTS			
(1) NAS1149F0463P Washer	=	(2) NAS1149F0432P Washers	
(1) A141-14 Washer	=	(5) NAS1149F0432P Washers	

SPANWISE WEIGHTS			
(1) NAS1149FN832P	=	(2) NAS1149FN816P Washers	
(1) C134-1 Weight	=	(14) NAS1149FN816P Washers	

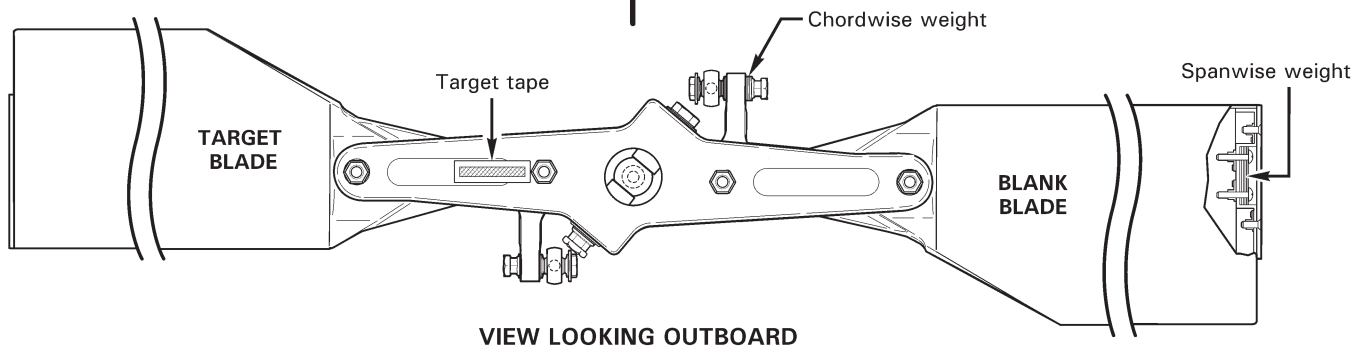
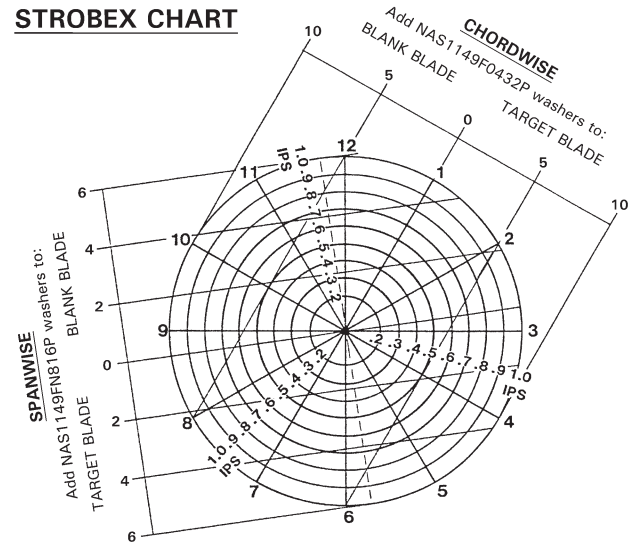
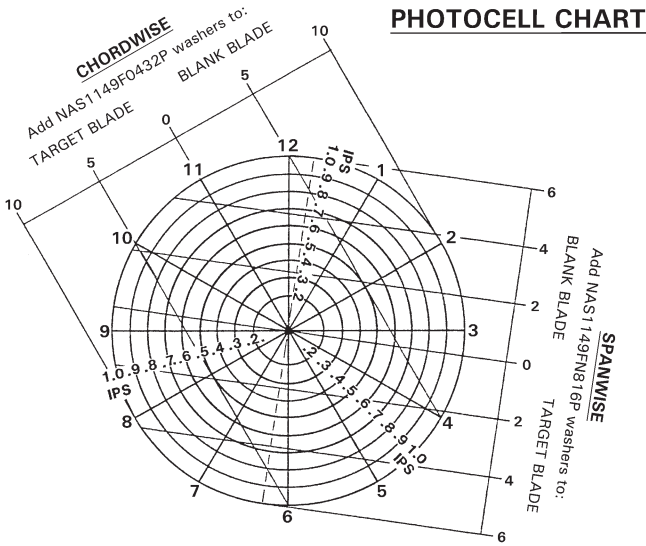

BALANCE	
CLOCK	IPS

ADJUSTMENT: \_\_\_\_\_

ADJUSTMENT: \_\_\_\_\_

ADJUSTMENT: \_\_\_\_\_

ADJUSTMENT: \_\_\_\_\_

**FIGURE 10-16 C008-2 TAIL ROTOR ASSEMBLY DYNAMIC BALANCE CHART**

Intentionally Blank

10.250 Autorotational RPM Adjustment

Use the following procedure for checking and adjusting autorotational RPM:

**WARNING**

**Failure to properly adjust autorotational RPM (RPM too low) may prevent the rotorcraft from achieving proper RPM at low gross weights.**

**NOTE**

Weight onboard = combined weight of fuel, people, & cargo onboard the helicopter.

1. Perform autorotation RPM check at less than 1900 lb gross weight. Calculate the weight onboard of the helicopter. Record the time on the hourmeter.

Weight onboard at take-off \_\_\_\_\_

Take-Off hourmeter reading \_\_\_\_\_

2. Set the altimeter to 29.92" Hg (1013.2 millibars) prior to performing the autorotation. Autorotate with the collective control firmly held against the down stop with an airspeed of 50 KIAS.

**WARNING**

**Do not allow the rotor to overspeed when performing autorotation checks. Progressively lengthen both main rotor pitch link rod ends until full down collective can be obtained without overspeeding the rotor.**

Take at least 3 RPM readings at 500 to 1000 foot altitude intervals. Record the following in-flight data:

Test No.	1	2	3	4	5
<b>Hourmeter Reading</b>					
<b>OAT</b>					
<b>Pressure Altitude</b>					
<b>Test %RPM</b>					

10.250 Autorotational RPM Adjustment (continued)

3. After test flight, refer to Figure 10-17 chart and determine following:

Test No.	1	2	3	4	5
<b>Elapsed Time</b> (in-flight hourmeter reading minus take-off hourmeter reading)					
<b>lbs of Fuel Consumed</b> (elapsed time x 93 lb/hr)					
<b>Weight onboard</b> (take-off weight onboard minus fuel consumed)					
<b>Test Longitudinal Center of Gravity</b>					
<b>Chart % RPM</b>					
<b>Test % RPM</b> (from in-flight data)					
<b>RPM Correction</b> (chart % RPM minus Test % RPM)					

\* Chart Instructions:

- a. Start at outside air temperature, and draw a vertical line up to pressure altitude.
- b. Draw a horizontal line from pressure altitude to weight onboard at time of autorotation.
- c. Draw a vertical line down from weight onboard to required auto RPM.

Note: Increase rotor RPM 0.75% for every inch that CG is forward of FS 100.0.

4. Adjust pitch links based on average RPM correction required. Lengthen both pitch links equally to decrease RPM if test RPM is greater than chart RPM; shorten both pitch links equally to increase RPM. One full turn of D173-3 rod end will change RPM approximately 3½%. Adjust both pitch links exactly the same so track will not be affected.
5. Repeat steps 1 thru 4 as required until the RPM correction is ± 1% of chart RPM.

## R44 Autorotation RPM

### COLLECTIVE FULL DOWN 50 KIAS

Refer to § 10.232 for pitch link adjustment.

One full turn of barrel or link assembly = approximately 3% RPM change

One full turn of D173-3 rod end = approximately 3½ % RPM change

**NOTE**  
Increase Rotor RPM 0.75% for every inch that CG is forward of FS 100.0.

**Example:** OAT = 20°C, Hp = 2000 ft, Weight on board = 300 lb, CG = FS 98.0  
Target RPM = 99% + (2 x 0.75%) = 100.5%

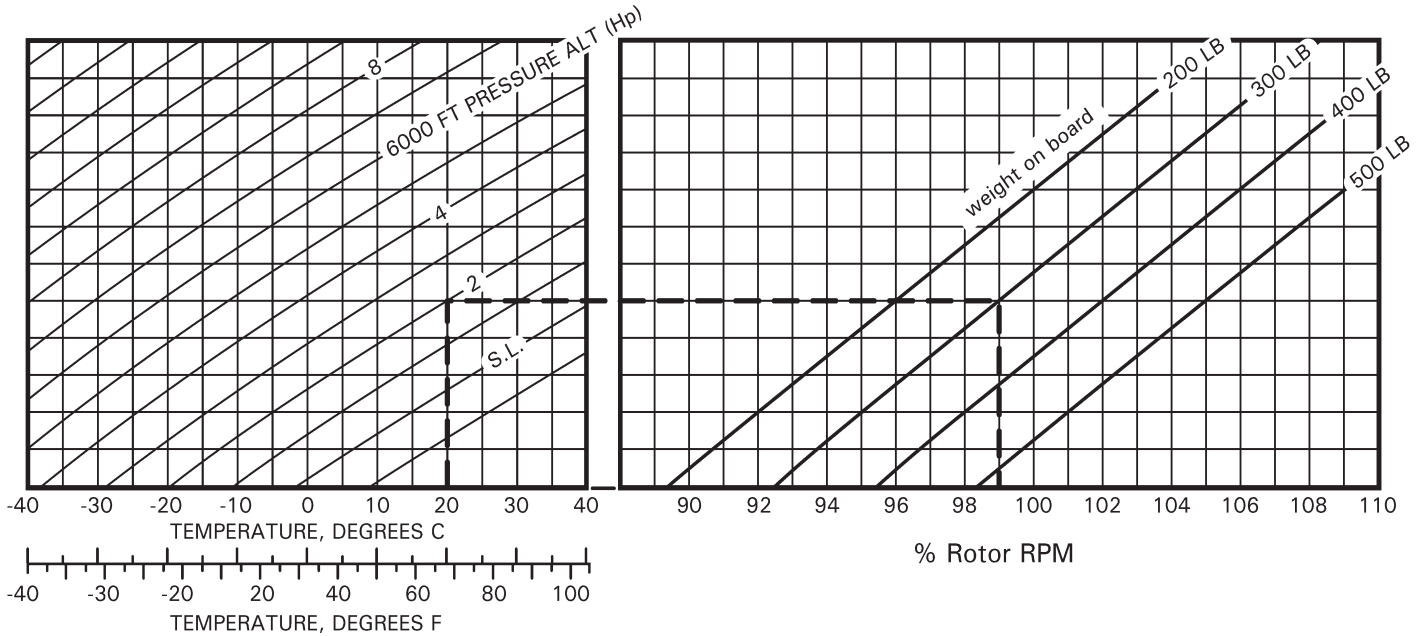

FIGURE 10-17 R44 AUTOROTATION RPM

Intentionally Blank